

masibus

A Sonepar Company



Products for Pharma



Masibus Pharma Range of Products



DDU-26



DDU-46



CDU



FDU



HT7S11S



DPT7S10

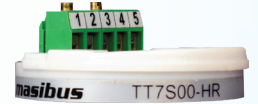

TT7S00-HR



TT7S10-XP



UC12

Time Synchronization

Clean Room & Filter Display Unit

Humidity & Temperature Transmitters

Enhanced Weather Proof Scanners

Smart Data Loggers

Universal Calibrators

Intelligent IO's (MINT)

Zigbee Wireless Converters

Protocol & Media Converters

Single & Dual Channel Signal Isolator

Multi Channel Vibration Monitor



AI-4 CH

AI-8 CH



VSW-160



MSC-ME-ZB



HT16Ew



9000E



9000LE



MSC-RE-RS



MSC-RS-RS



Time Synchronization Solution for Pharma Industry



MC-2



DDU-24



DDU-26

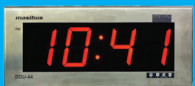

DDU-44



DDU-46

GPS Wireless Master Clock- MC-2

Features

- Receives automatic time from network of GPS satellites
- Transmits the time to clocks through RF or serial
- Synchronization of server time system through RS-232/RS-485

Wireless Slave Clock- DDU-24/ 26

Features

- Each clock can act as repeater to extent network range
- Works in stand-alone mode if network fails
- DDU-24 / DDU-26 is also available in Ex-proof enclosure for gas group IIA and IIB (IP65)

Wireless Slave Clock- DDU-44/ 46

Features

- Use of unlimited slave clocks within transmitter's range
- Optional TP (LAN Interface) with IEEE 802.3af compliant PoE
- Retains time during loss of power/time code

Wireless Master Slave with Slave Retransmission

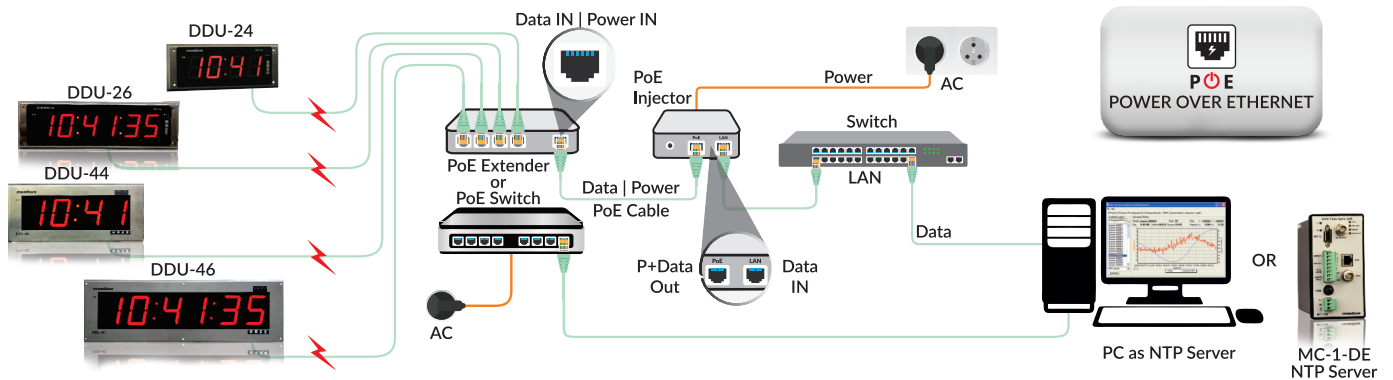

DDU 24/26 or DDU 44/46 Wireless & NTP PoE Synchronized Slave Clocks

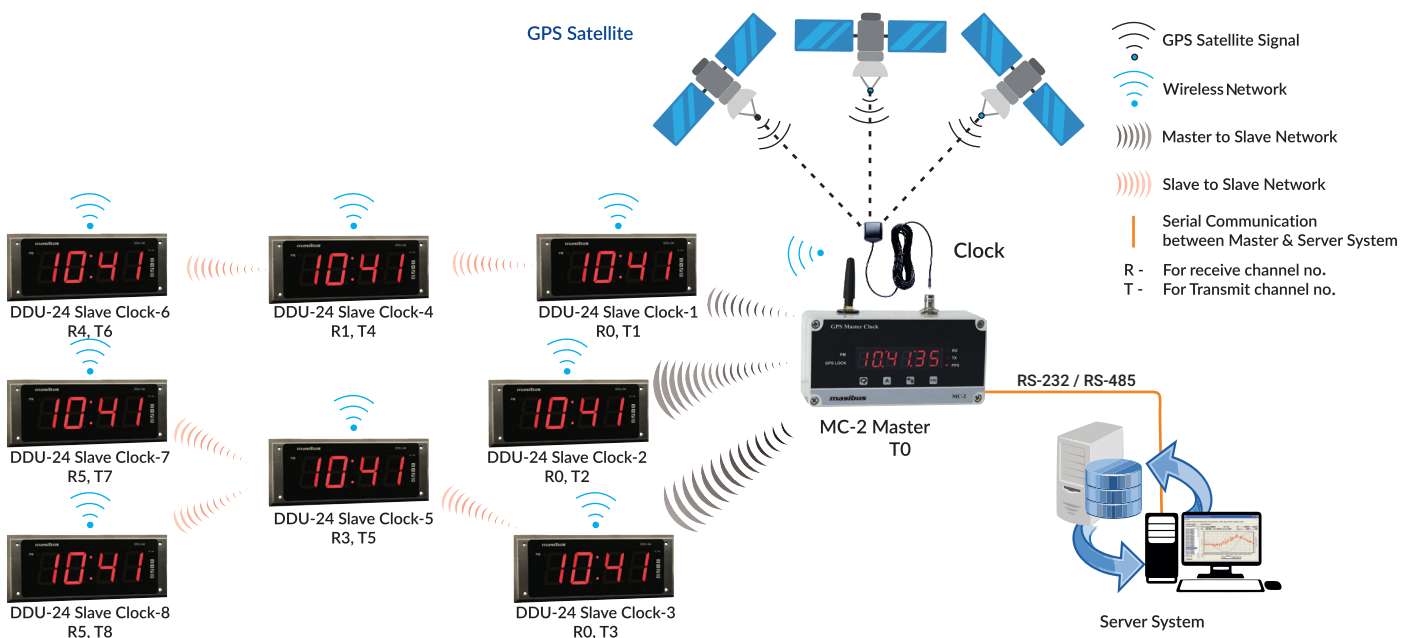



Transmitter Offerings



TT7S Isolated & Programmable Temperature Transmitters

Features

- Universal input (RTD, Thermocouple, Ohm, mV)
- Full three port isolation
- Linearized output
- Highly accurate
- Fully programmable for input type & range



TT7S11S



TT7S10



TT7S10-H

TT7S00-HR 2-Wire Transmitter Pt-100 input

Features

- Multi-range design
- Output linear to temperature
- Analog linearized for 0.1% linearity
- Sized for DIN B heads and bigger
- Sensor break selection for upscale or downscale

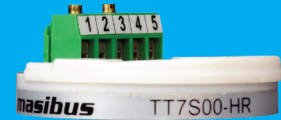

TT7S00-HR



TT7S10-D



TT7S10-XP
(Single Compartment)



TT7S10-XP
(Dual Compartment)

TT7S10-D/TT7S10-XP Loop Powered Temperature Transmitter with Display

Features

- Universal input (RTD, Thermocouple, Ohm, mV)
- Available in below options
 - TT7S10-D: DIN-Rail mount with 0.3", 4 digit LED display
 - TT7S10-XP: Wall or 2" pipe mount Ex-proof transmitter with touchsense keys
 - 0.56", 4 digit LED display in single compartment
 - 0.39", 4 digit LED display in dual compartment
- 1.5 KV RMS isolation between input & output
- Linearized output
- Highly accurate
- Fully Programmable for input type & range
- Digital filter
- Easy configuration using front keys and software



Transmitter Offerings



DPT7S10

DPT7S10 Differential Pressure Transmitter

Features

- Wide loop supply voltage range from 10VDC to 36VDC
- Custom built LCD 4-digit display
- Configurable unit measurement in mmWC / Pa
- Available in compact and lightweight design for easy and simple wall mount installation
- Configurable by front keypad (Available in device with display)



HT7S11S

HT7S11S Humidity and Temperature Transmitter

Features

- Wide loop supply voltage range from 10VDC to 36VDC
- Custom built LCD display
- Configurable temperature unit measurement in celsius/fahrenheit/kelvin
- Available in wall and duct mount
- Configurable by front keypad (Available in device with display)

T/RH Transmitter and DP Transmitter for Clean Room Application



Indicator Offerings



CDU Clean Room Display Unit

Features

- RH, temperature and DP measurement
- Internal sensor option (Ease of installation)
- Remote sensor option for RH+T measurement
- Available in LED and touchscreen TFT LCD display options
- 3 Programmable alarms with visual annunciation
- Data backfilling via DNP 3.0 avoiding data loss



CDU (LED)



CDU (LCD)

Environment Monitoring System

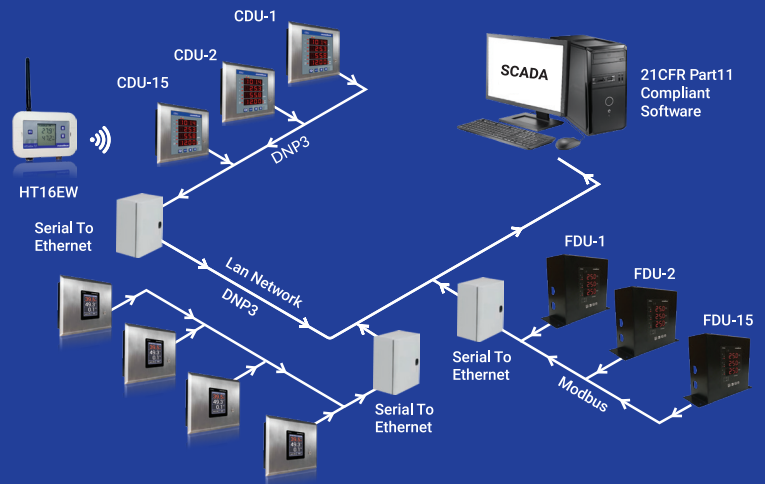

FDU Filter Display Unit (For AHU & BMS Systems)

Features

- Micro-controller based differential pressure indicator cum transmitter up to 3 filters
- Software programmable filter ranges
- 3 Programmable Hi/Lo alarms with audio/visual annunciation
- RS-485 Modbus RTU communication for connectivity with BMS/ PLC/ SCADA etc.
- Built in AHU OFF/TRIP status LED indications via digital input



FDU

Filter Display Unit for BMS/ EMS

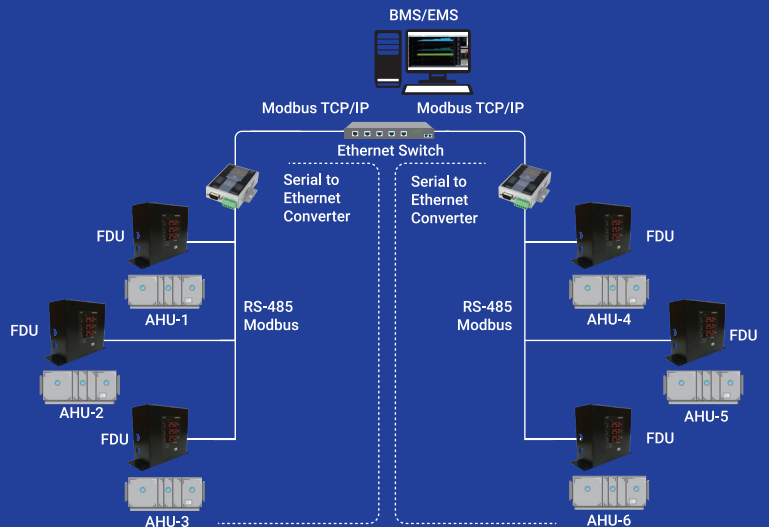

PHI-22-XP Flame-Proof pH Indicator

Features

- 5 Point calibration
- Slope/offset adjustment
- Built-in-diagnostics
- User selectable: Auto/manual temperature compensation
- Electrode performance indicator



PHI-22-XP

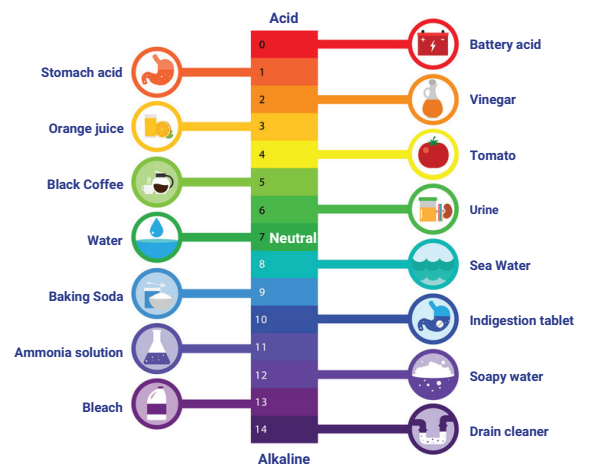



Isolator Offerings

9000LE- Single / Dual Channel Signal Isolator

Features

- Compact DIN-Rail mount design of 35mm with one or two-channel option
- Highly stable against temperature variation, Drift ≤ 50 PPM
- 2 wire & 4 wire transmitter configuration option available
- High response time $\leq 50\mu\text{s}$
- BEST IN CLASS ACCURACY, $\leq 0.1\%$ of full span
- HART pass-through available with 2- wire transmitter supply configuration
- Low power consumption, ≤ 1.3 W per channel with TPS, ≤ 0.7 W per channel without TPS & low cost per channel



9000LE



Process Industries Application

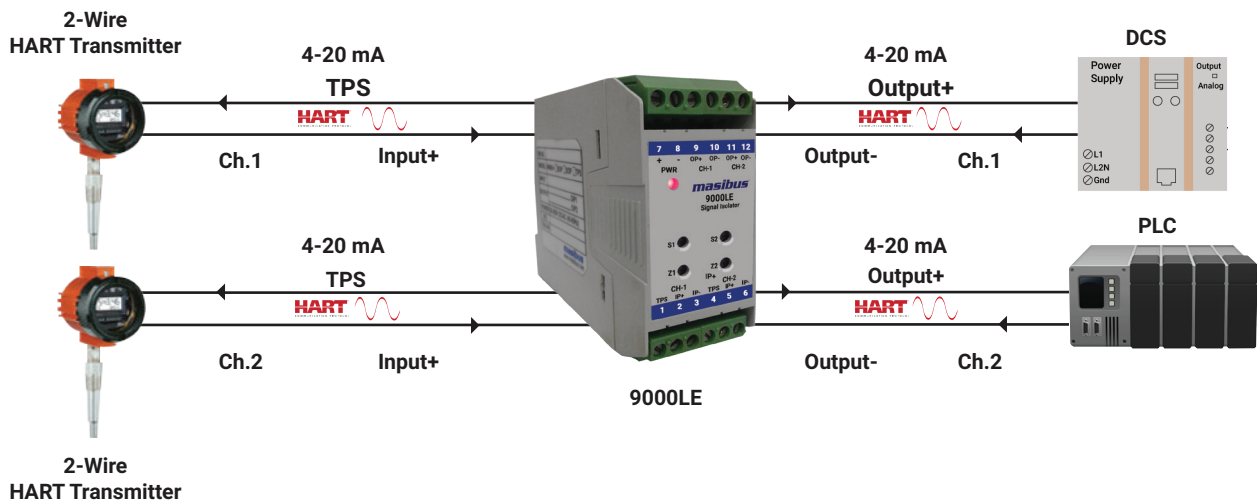

9000E- Signal Isolator

Features

- Compact DIN-Rail mount design of 17.6mm width
- 2W transmitter input with HART Pass
- High KV 3 port isolation
- High accuracy, low drift & low temperature effect
- Input and output well protected
- Fast response suits all applications
- High CMRR and NMRR
- Slim design for one/two channels



9000E

9000C- Signal Isolator

Features

- Available in Aux Powered (AP) and Loop Powered (LP) options
- Slim DIN-Rail mount design of 12.5mm for single output and 17.5mm for dual output
- Rugged & accurate 4 wire and 2 wire Isolator
- Up to 2 outputs with short circuit protection
- CE certified model option
- HART pass through model



9000C





Calibrator Offerings



UC12 Universal Calibrator

- Portable multifunction calibrator with high accuracy in all modes of operation.
- Graphical user interface for precise measuring and sourcing of electrical and physical parameters.
- Designed to give maximum battery life in one full charge, the backlight is adjustable for power saving.
- Shortcut keys to operate easily for input selection for measure and source/ measure respectively.
- Comes with a mini USB connector for charging, logged data retrieval and firmware upgrade.
- Sourcing and measurement capabilities with independent parameter and range selection.
- It has mA/ V/ mV/ mA (2W)/ switch- test / RTD/ TC/ measurement capability & also has mA/ V/ mV/ mA(2W)/ Resistance/ RTD/ TC/ Frequency/ Pulse source capability.

UC12

Calibrate Pressure Transmitter using UC12

This calibration kit is designed to make multifunction calibration, pneumatic testing, and calibration of mechanical and electronic pressure measuring instruments for a fast and reliable process. This is a cost effective, high-quality, handy, and robust kit which is essential for those who need to perform service and maintenance on pressure & electrical instruments.

Handpump with Digital Pressure Gauge



Pressure Transmitter



UC12

4-20mA

The kit includes a pneumatic hand test pump, which allows you to generate a defined test pressure, and a highly accurate digital pressure gauge that serves as a reference instrument and process calibrator for measurement and calibration of process parameters. All the components of the kit are carefully stored in the case, providing protection during transport. The case is compact and easy to carry, making it convenient to take with you wherever you need to go.

Special Features

- Economical and simple operation for multifunction calibration
- Testing and adjustment of pressure gauges, pressure sensors, pressure switches, safety valves and electrical parameters
- Pressure accuracy with 0.05 % & 0.025% FS
- Pneumatic version from vacuum to 40 bar
- Hydraulic version from 0 to 700 bar



HART calibration using UC12

HART Communicator is a device used in the process control industry to configure, monitor, and diagnose field instruments. With a HART Communicator that includes a UC12 process calibrator option, users can calibrate and verify their field instruments quickly and easily, without the need for additional tools.

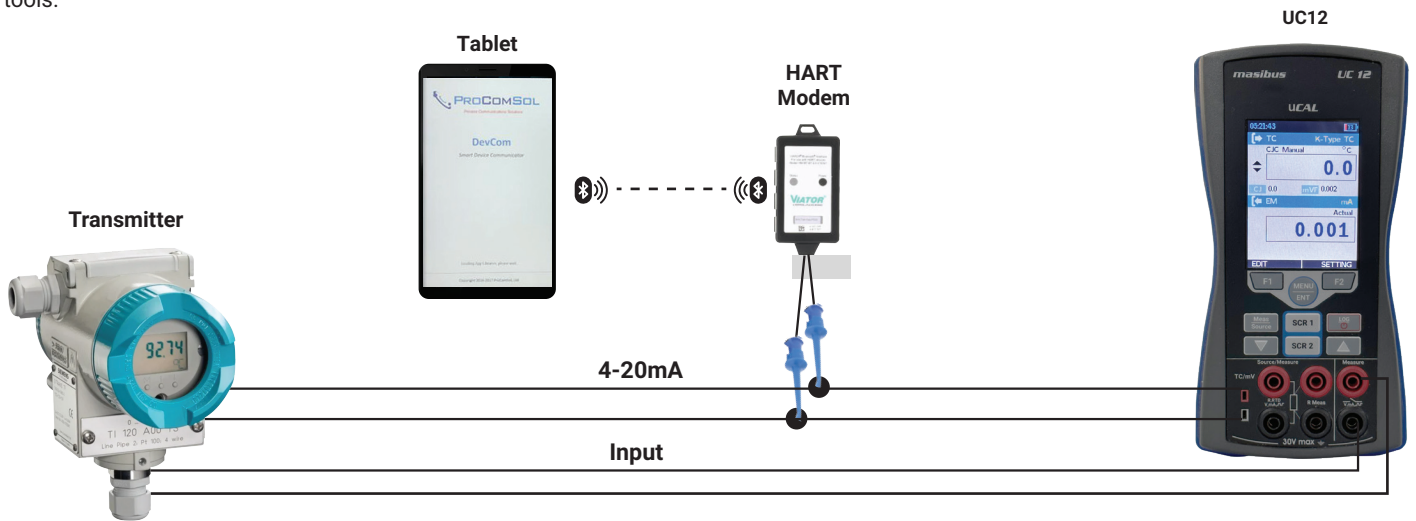

The process calibrator option allows users to apply a known input signal to the instrument and compare its output to the expected value. This enables accurate calibration and verification of the instrument's accuracy. In addition, a HART Communicator with a process calibrator option typically includes additional features such as measurement and simulation of electrical signals, allowing users to test and diagnose a wider range of instruments.

Special Features

- Full HART Device Description (DD) support of all HART devices with process calibrator
- Perform HART trim on HART devices
- Convenient wireless connectivity to HART modem
- Easy to use, fast connect and view HART data
- Connectivity through bluetooth and USB
- Use mobile and laptop HART communicator



TC12+ Temperature Calibrator

- Portable multifunction temperature calibrator with high accuracy in all modes of operation
- Graphical user interface for precise measuring and sourcing of electrical and physical parameters
- Designed to give maximum battery life in one full charge, the backlight is adjustable for power saving
- Shortcut keys to operate easily for input selection for measure and source/ measure respectively
- Comes with a mini USB connector for charging, logged data retrieval and firmware upgrade
- Sourcing and measurement capabilities with independent parameter and range selection
- It has mA/ V/ mV/ mA (2W)/ switch- test / RTD/ TC/ measurement capability & also has resistance/ RTD/ TC source capability



TC12+

I/O Cards from Masibus (MINT)

Features



- High performance IO system which can be connected with any brand of PLC / DCS / DAQ in centralized as well as in remote IO configuration
- 15 nos. of IO cards can be clubbed together in a row with one communication processor & same can be repeated for more rows
- Channel density for digital input & output is 16 channel, & for analog input & output is for 8 channel. AI card can accept universal input
- Can be integrated with existing plant network over Modbus RTU / Modbus TCP/IP protocol
- Smart IOs to capture field sensors information to IIoT gateway, which can further be pushed to cloud
- MINT IO's comes with below different options 1 RS-485 Port, 1 RS-485 + Ethernet Port, 2 RS-485 Port

Protocol Support - Modbus RTU, Modbus TCP / I/P

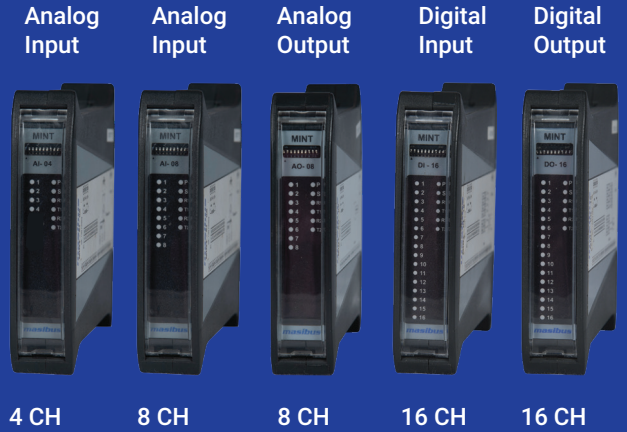

Can be connected with any make of PLC-CPU as I/O Card
Can be connected as Data Concentrator/Collector for IIoT Application

MINT IOs					
Model	4-AI	8-AI	8-AO	16-DI	16-DO
Channels	4	8	8	16	16
Type	Voltage/Current (Fix)	RTD/TC/ Voltage/Current (Universal)	Voltage/Current	24V DC input	Open collector 24VDC sink/ source 100mA per O/P
Isolation	Supply to field: 1500VAC RMS, Supply to RS-485: 1500VAC RMS, Field to logic: 1500VAC RMS				
Scan Time	50ms/ Ch.	RTD-100ms/Ch. Other-50ms/Ch.	All 8 Ch. in <500ms	500 μs	Configurable
Resolution/ Accuracy	16 bit ADC 0-1 %	16 bit ADC 0.1%	16 bit DAC 0.05%	1 KHz 32 Bit Counter	10ms Pulse O/P

PLC with IOs on RS-485 - Modbus RTU

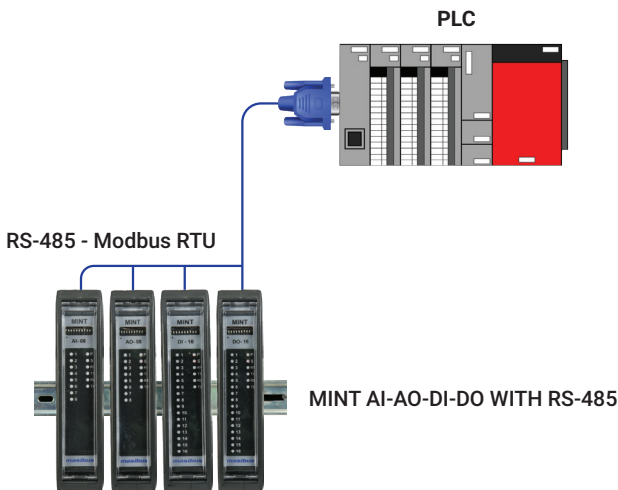

Mint CP with I/O on Modbus TCP/IP to PLC & Mint IO's to HMI on RS-485-Modbus

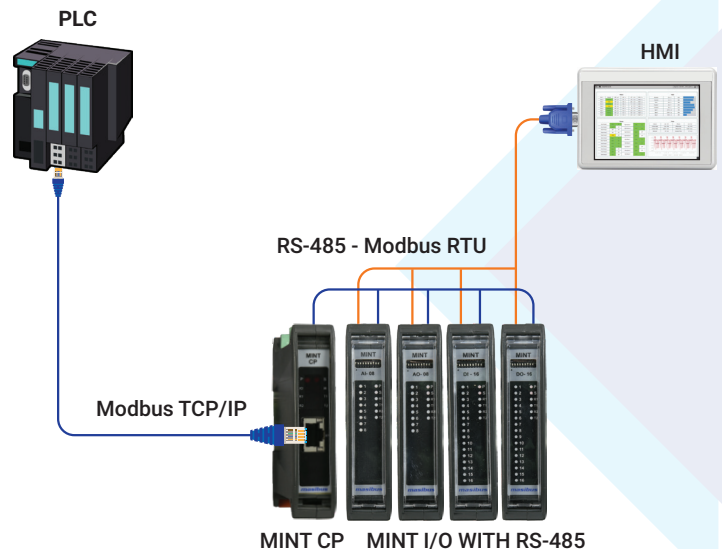



Application Examples

MINT-DI as 1 KHz High Speed Counter

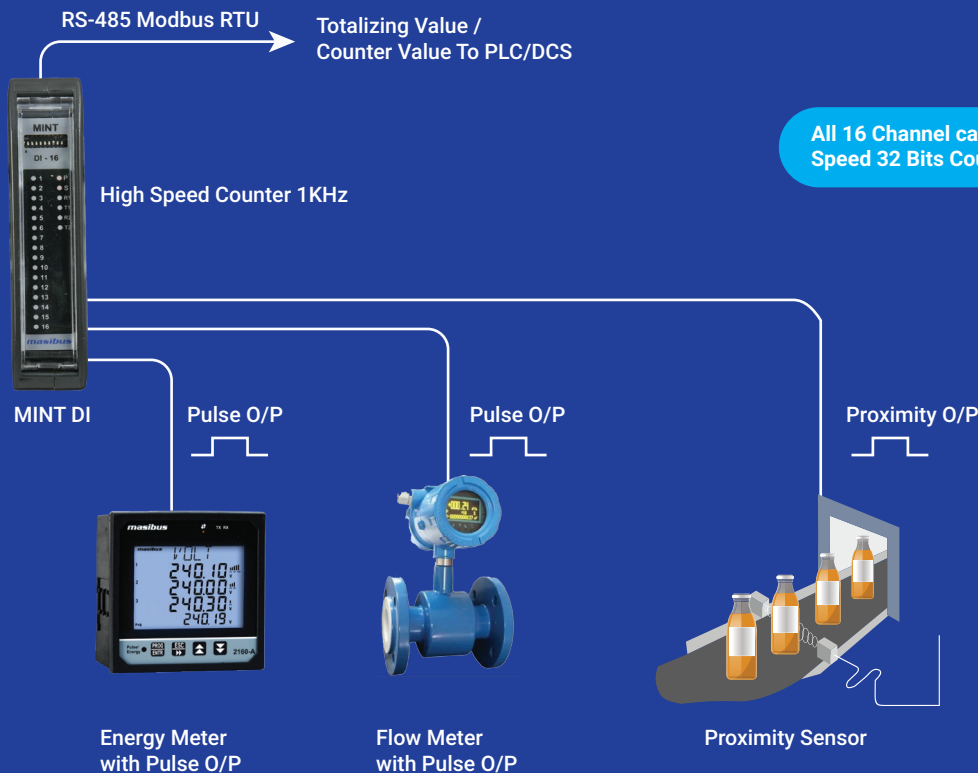

I/O Pair for Analog Input

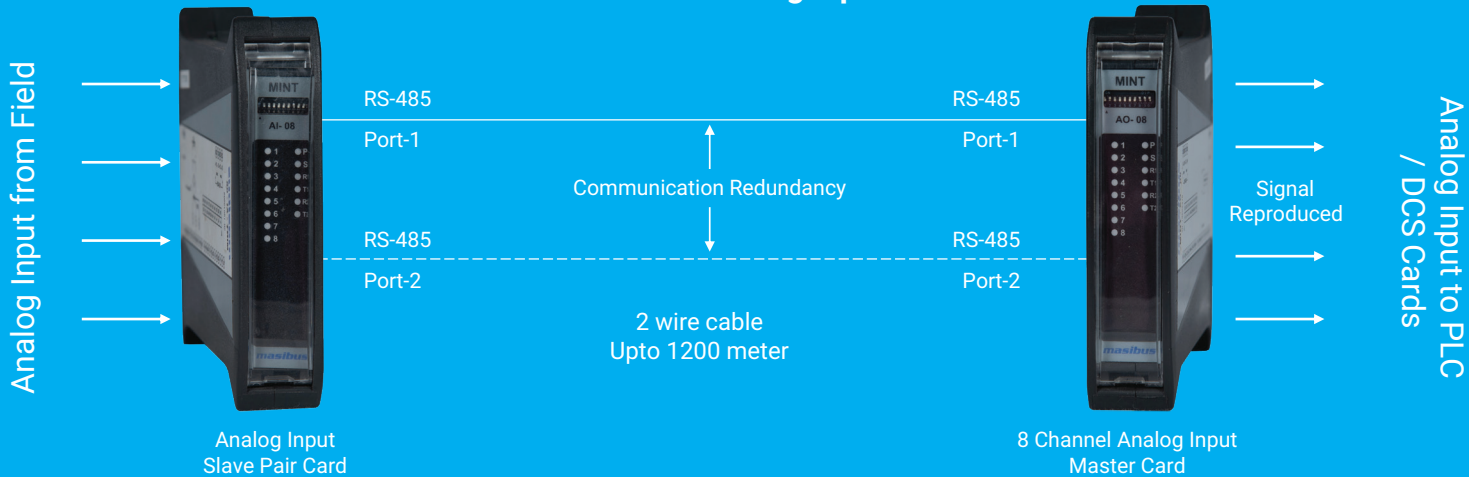

I/O Pair for Digital Input

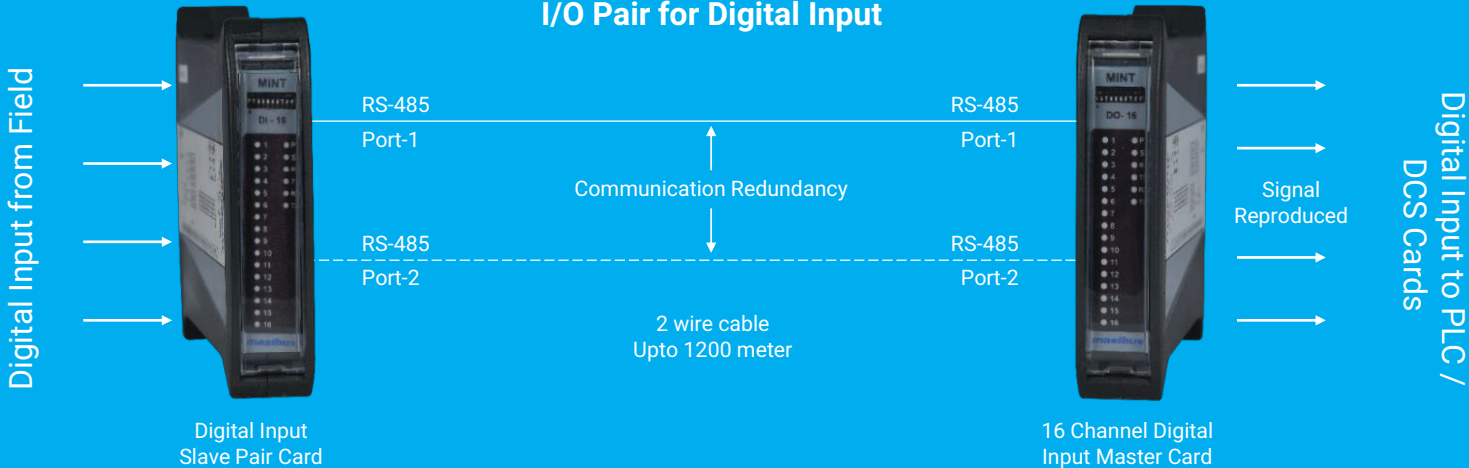



Application Examples of Weather Proof Scanner 8208-IP

8208-IP as Transformer Protection Relay

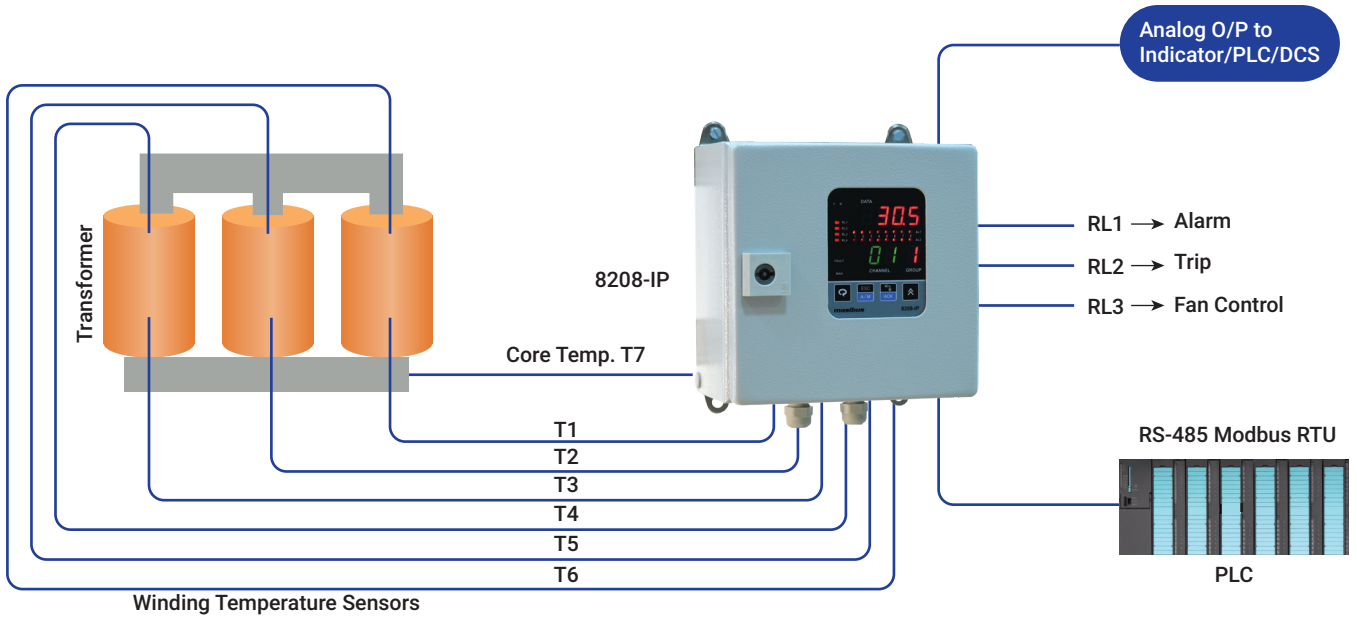

Features

- IP65 for Weather proof protection
- Fast sampling rate with instantaneous relay action
- RS-485 serial communication port for remote monitoring
- Multiple levels of configuration and password protection
- Comprehensive alarm/trip logic programming
- Re-transmission output (Optional)
- Universal analog inputs
- Four relays for alarm/trip

Motor Temperature Measurement & Protection

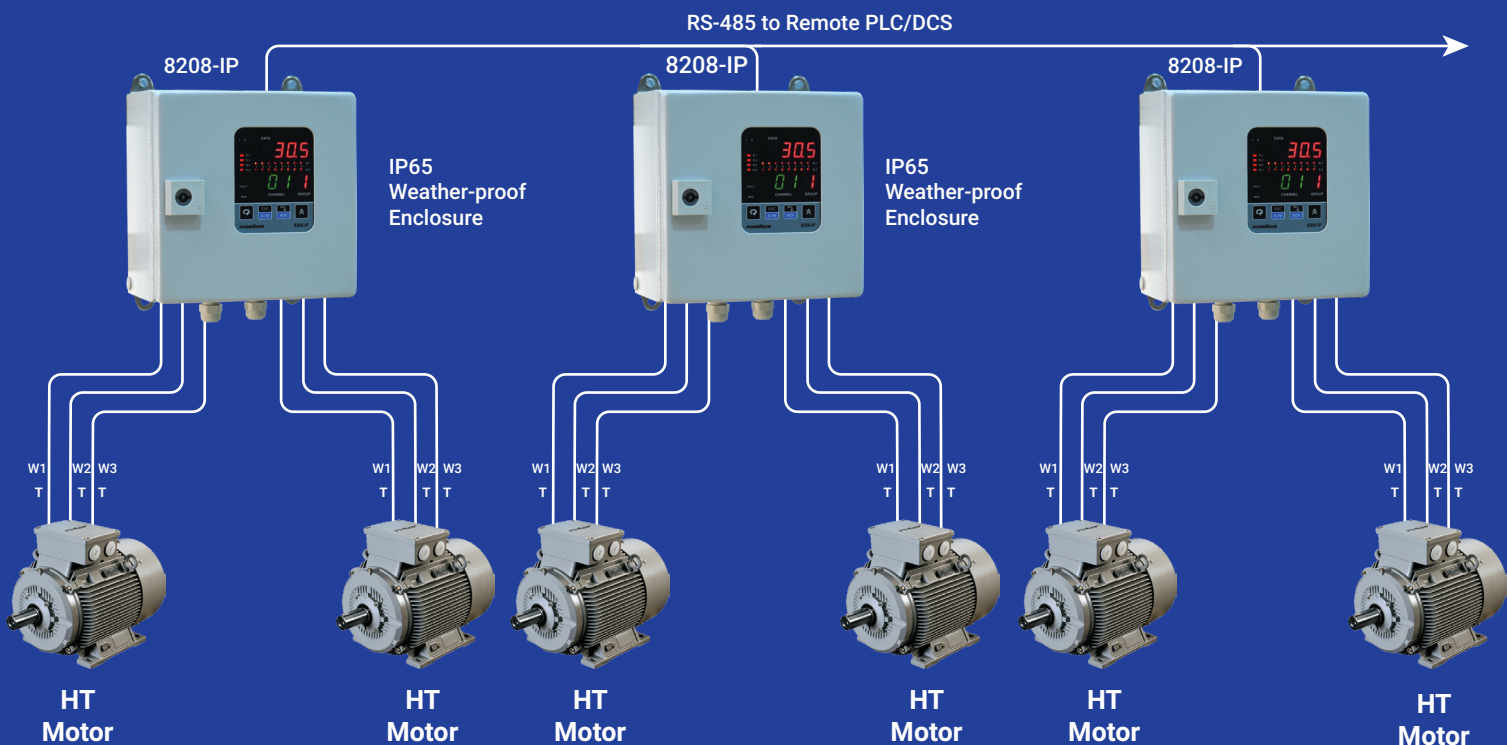

Busbar Junction Temperature Monitoring for Preventive and Predictive Maintenance of LT Distribution Panels

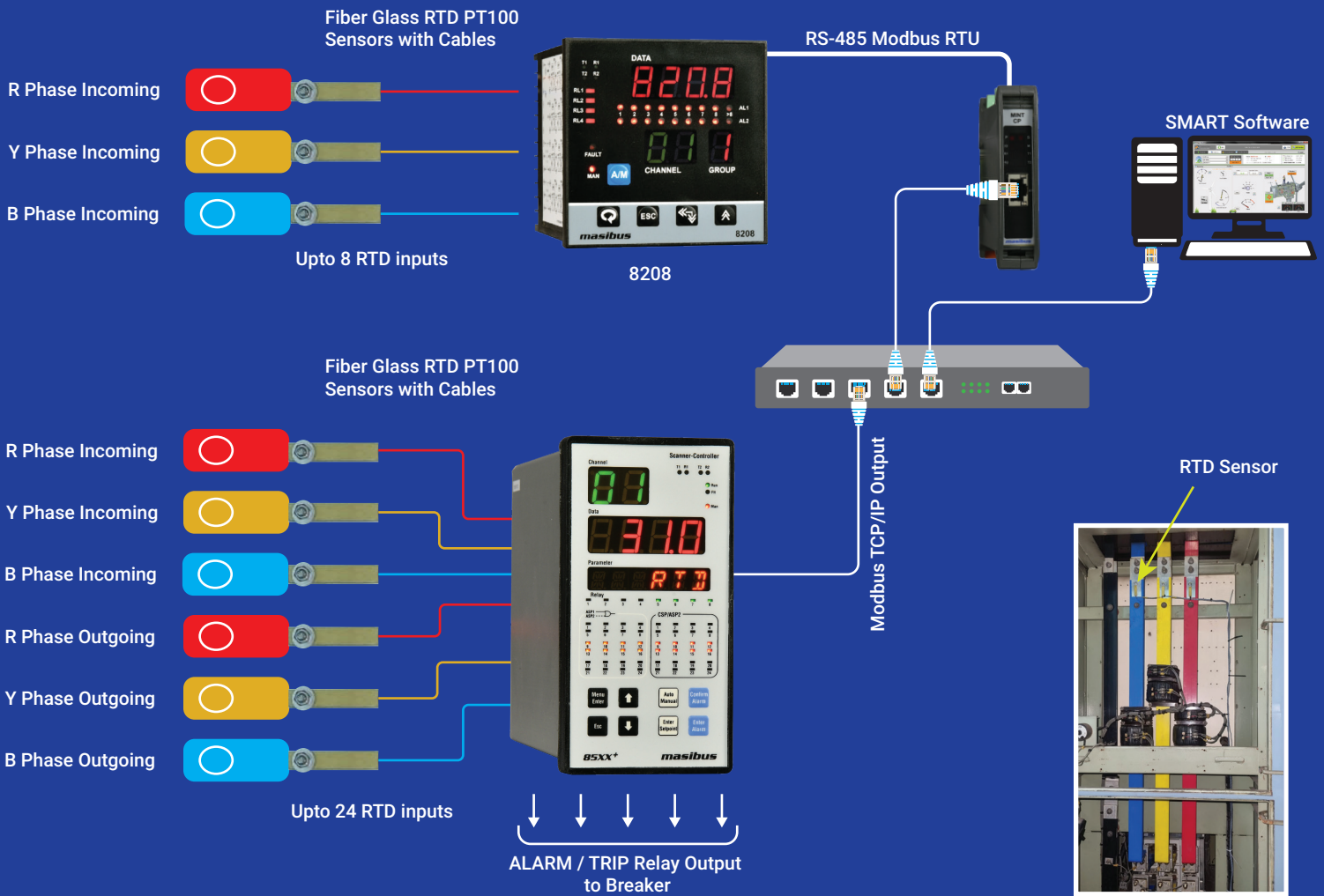

8040 Data Logger Applications



8040-128 Channel Data Logger



Benefits

- 128 Channel universal input
- Channel to channel isolation
- 3 Second update rate
- 32 MB Internal memory
- Periodic & event based data logging
- RS-485 & Ethernet communication port available



MSC-ME-ZB
(Modbus-Zigbee to Modbus
TCP/IP Data Concentrator/Gateway)



MSC-ZB-RS
(RS-485 Serial to ZigBee
Wireless Converters)

MSC-ME-ZB

Features

- Supports upto 64 Modbus RTU Slave devices on RS-485 & ZigBee
- Number of Master Ports (Modbus RTU): 1 RS-485 (Wired) & 1 ZigBee (Wireless) - Only one active at a time
- ZigBee Topology: Point-Point/Point-Multipoint/Mesh
- Modbus TCP/IP (ModNet) - 10/100Mbps- Auto detecting
- No. of client supports on Modbus TCP/IP (ModNet) - Up to 15
- Supports up to 192 commands or 2048 Read/1024 Write Registers on Modbus

MSC-ZB-RS

Features

- Number of ports: 1 RS-485 (Wired) & 1 ZigBee (Wireless)
- ZigBee Topology: Point-Point/Point-Multipoint/Mesh
- Router/Co-ordinator/Aggregator/Master/Slave configuration through MSC studio
- MSC-ZB-RS (Router/Slave) can connect to MSC-ME-ZB or MSC-ZB-RS (Co-ordinator/Master)
- Wireless range extension possible through router

Connecting 64 Modbus Devices Wirelessly Inside a Plant

100 Meter Indoor/ Upto 1 KM Outdoor (LOS)

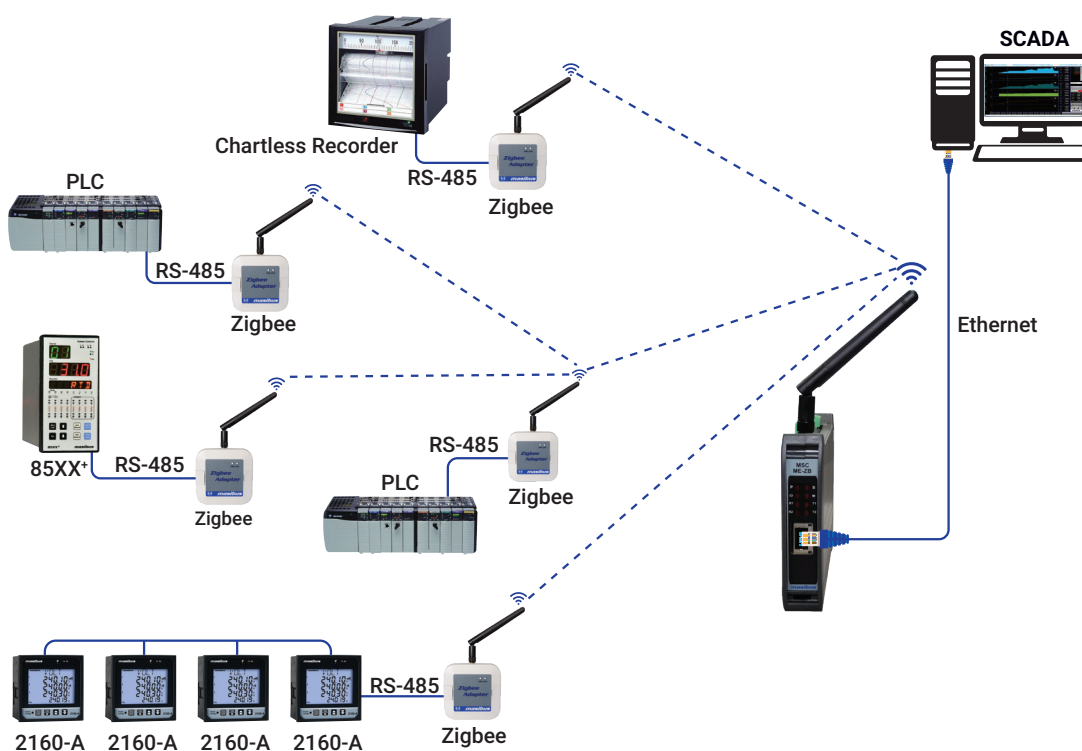



HT16u- Humidity Temperature Smart Logger



Features

- USB based HT16u with internal or external RH/T sensor with SS filter
- Temperature measurement -20 to 60 °C / -3.8 to 140 °F
- Humidity measurement 0 to 100 %
- Best in class accuracy @ 25°C +/-0.2°C temperature & +/- 2% RH
- Ultra low - Battery power consumption with long life - CR2450 coin cell battery (1 Year @15min logging)
- Display battery status
- Logging start/stop - manual or pre-programmed (Auto) with pause facility
- SMART-HT free version - 3 devices in single report - Excel/PDF (Alarms & periodic data)
- SMART-HT license version - 10 Devices in single report/password protection in reports/21-CFR compliance with audit trails



HT16u

Warehouse Layout - Room Temperature Mapping



SMART HT Software

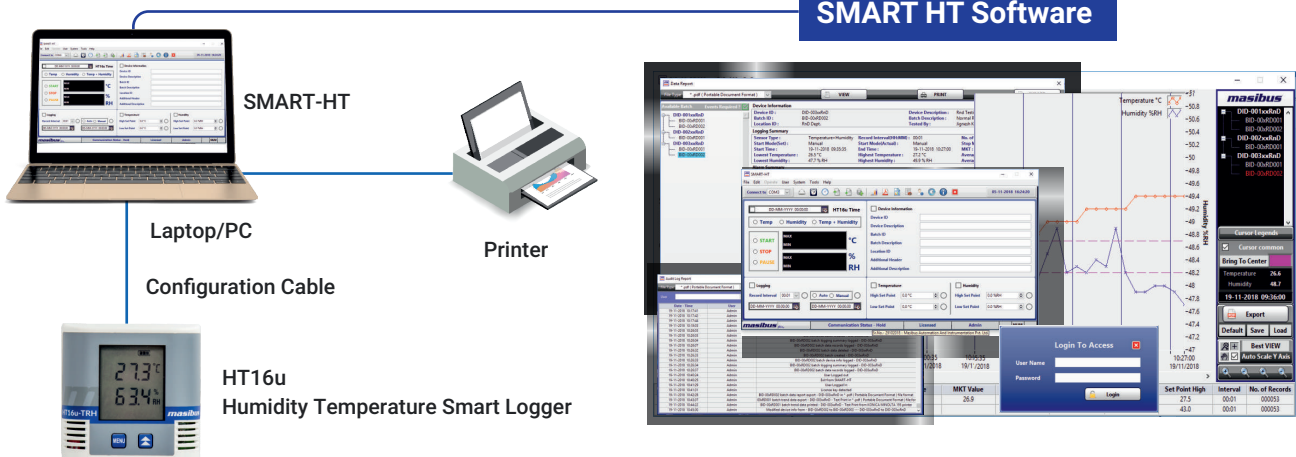

Pharma Industries

Clean Rooms & Warehouses

Food Industries

Cold Storages

Calibration Service Industries



Protocol and Media Converters

Protocol Converters



MSC-ME-MS
(Modbus Serial to Modbus
TCP/IP Data Concentrator/Gateway)

Features

- Supports max. upto 247 Modbus RTU slave devices on RS-485
- No. of RS-485 ports (Modbus RTU master): 1 No.
- Modbus TCP/IP (ModNet) - 10/100Mbps- Auto detecting
- No. of client supports on Modbus TCP/IP (ModNet) - Up to 4 No.
- No. Modbus query configuration

Features

- It converts Modbus Serial to Modbus TCP/IP
- Supports max. upto 64 Modbus RTU slave devices on RS-485
- No. of RS-485 ports (Modbus RTU Master): 2 (Only one active at a time)
- Modbus TCP/IP (ModNet) - 10/100Mbps- Auto-detecting
- No. of client supports on Modbus TCP/IP (ModNet) - Up to 15
- Supports upto 192 Modbus commands
- 2048 Read/1024 Write Registers on Modbus



MSC-RE-RS
(Modbus Serial to Modbus
TCP/IP Protocol Converter)

Media Converters

Features

- RS-485 half duplex communication
- Communication speed (Baud rate) 1200 - 115200 bps
- Auto baud rate detection
- Signal boost up to 1200m (Depends upon baud rate)
- Maximum 30 RS-485 nodes per repeater
- 120Ω termination resistor selection
- Isolation 1500VAC RMS



MSC-RS-RS
(Isolated RS-485 to RS-485 Repeater)

- Convert the signals to RS-232
- Port: 9 PIN DB male connector
- Output - RS-232 full handshaking



mUSB232
(USB to RS-232 Converter)



mUSB485
(USB to RS-485 Converter)

- Convert the signals to RS-485 level
- Outputs: D + / D -
- Maximum 32 nodes
- 120Ω termination resistor selection

MSC-ME-MS as Modbus Gateway OR MSC-RE-RS as Modbus Protocol Converter

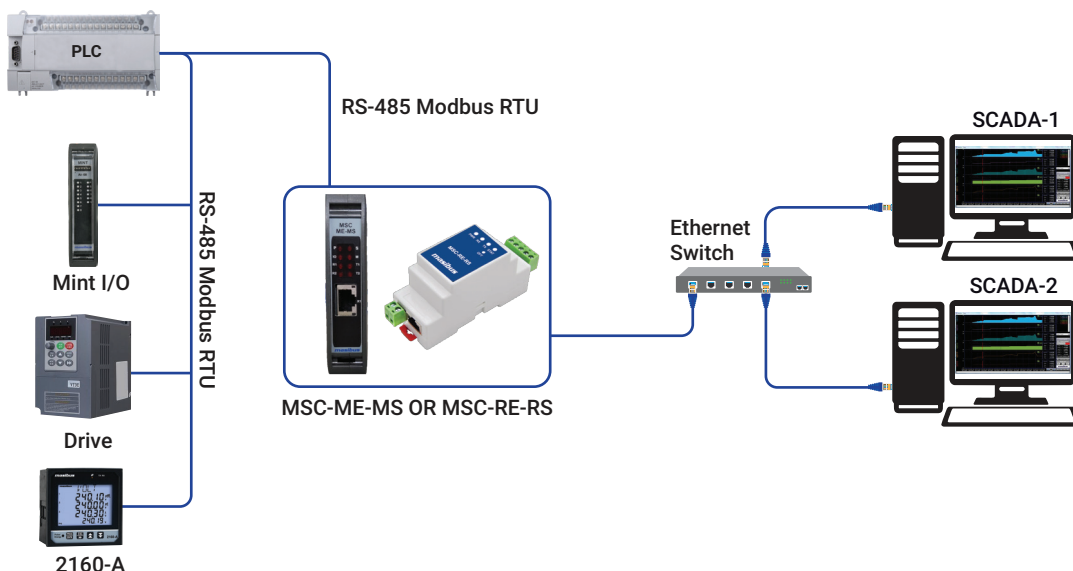



VSW-160 - Vibration Switch



VSW-160

Features

- 3 in 1 - Switch/ Indicator/ Transmitter
- Capacitive touch screen operation - Ease of maintenance
- Built-in remote sensor option
- Type of protections: Flameproof (Explosion proof) EX-d
- Area classification: Zone 1 & 2, Gas groups: IIA/ IIB & IIC
- Trim port for vibration set-point adjustment

Vibration Monitoring of Centrifuges

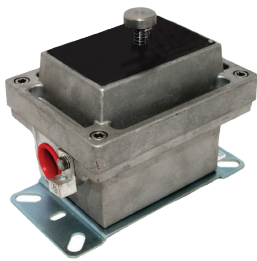

Old
Mechanical
Vibration Switch



New
Electronic
Vibration Switch

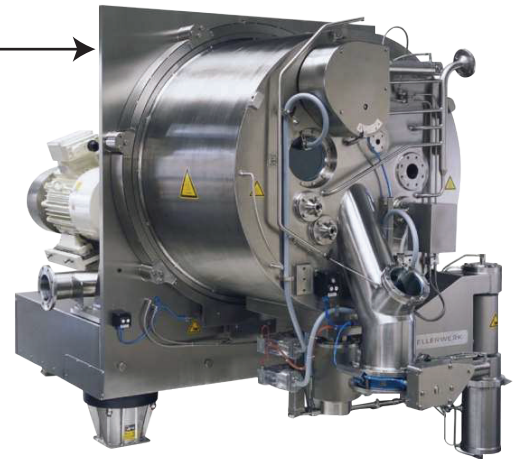

VMS4SE - Multi-Channel Vibration Monitor

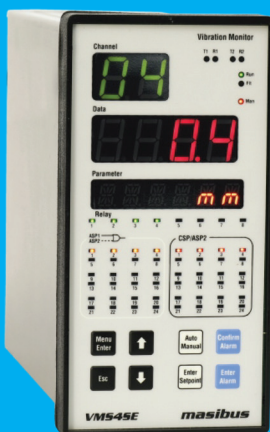

VMS4SE

Features

- Configurable upto 8 vibration channels
- Can accept analog inputs (Temperature, Current & Sound)
- Additional buffered output on BC connector for analysis
- RS-485 & Ethernet Port for interface with PLC, DCS, SCADA & HMI
- Extruded aluminum chassis with IP-55 front fascia
- Field configurable for acceleration, velocity or displacement range
- Modbus RTU over serial and Modnet over Ethernet Protocols



Masibus Partner Products for Pharma Industry



**Beamex
MC6**



**Beamex
MC6-EX**



**Multi Function
Test Bench**



**INOR
R530**



**VibraSens
Accelerometer**



**VibraSens
Loop Powered Sensor**



**EWON
Cosy 131**



**EWON
Flexy 205**



**PULS
FIEPOS**



**PULS
PIANO**

Advanced Field Calibrator and Communicator

beamex

Features

- **Accuracy**
High-accuracy, advanced field calibrator and communicator.
- **Usability**
Combines advanced functionality with ease-of-use.
- **Versatility**
Versatile functionality beyond traditional calibration applications.
- **Communicator**
Multi-bus communicator for HART, FOUNDATION Fieldbus and Profibus PA instruments.
- **Integration**
Automates calibration procedures for paperless calibration management.



Beamex MC6

Intrinsically Safe Advanced Field Calibrator and Communicator

- **Safety**
Approved for Ex ia IIC T4 Ga – classification.
- **Versatility**
Versatile functionality beyond traditional calibration applications.
- **Communicator**
Full multi-bus communicator for HART, FOUNDATION Fieldbus and Profibus PA instruments.
- **Internal loop supply**
MC6-Ex features an internal loop supply for transmitters, so no additional supplies are needed.
- **Integration**
Automates calibration procedures for paperless calibration management.



Beamex MC6-EX

Multi Function Test Bench

Features

- Calibration facility for pressure, temperature & electrical instruments
- Flexible maintenance - Device modules structure
- Option for (HART, PA, FF) communication
- Documenting version available with PC connectivity





Accelerometer

Features

- Uniaxial Accelerometer output 10mV/g, 50mV/g, 100mV/g, 500mV/g
- Electrical connection: M12 Connector, MIL grade connector and integral cable
- Annular shear technology
- Temperature output also available
- ATEX certified
- Hermetic glass sealing

Features

- MEM's based Loop powered sensor
- Velocity output in form of 4-20mA
- Electrical connection: M12 connector, MIL grade connector and integral cable
- Suitable for frequency 10Hz- 1KHz
- DA/DV/Temperature output also available



Loop Powered Sensor

PULS Power Supply



DC-UPS
Efficient, compact & reliable DC-UPS



FIEPOS
Decentralized field power supplies



PIANO
Cost effective, long lifetime DIN-Rail power supply



DIMENSION
High efficiency & reliable power supply



No. 1 Manufacturer of **Din-Rail** Power Supplies



World's **Slimmest** Power Supply



Upto **95.6%** Efficiency- **New Record** for Power Supplies



FIEPOS- Available in **IP54, IP65 & IP67**



Designed in **Germany**



3 year warranty for all PULS standard products

Special Standards and Approvals

CE & UL Approval | ATEX Approval | IECEx Products | Class I Div 2 | Railway EN 50155 | NEC Class 2 | Marine Approval

Benefits of Industrial Remote Access

- Minimize downtime through fast remote support
- Save time and money by avoiding unnecessary service trips

State-of-the-art Security

- New generation of devices with built-in hardware security
- Increase safety with digital output indicating active connection

Successful Worldwide Connectivity through Talk2M

- Scalability: Add as many devices & users you need at any time
- Email & SMS services- Receive notifications from your machine

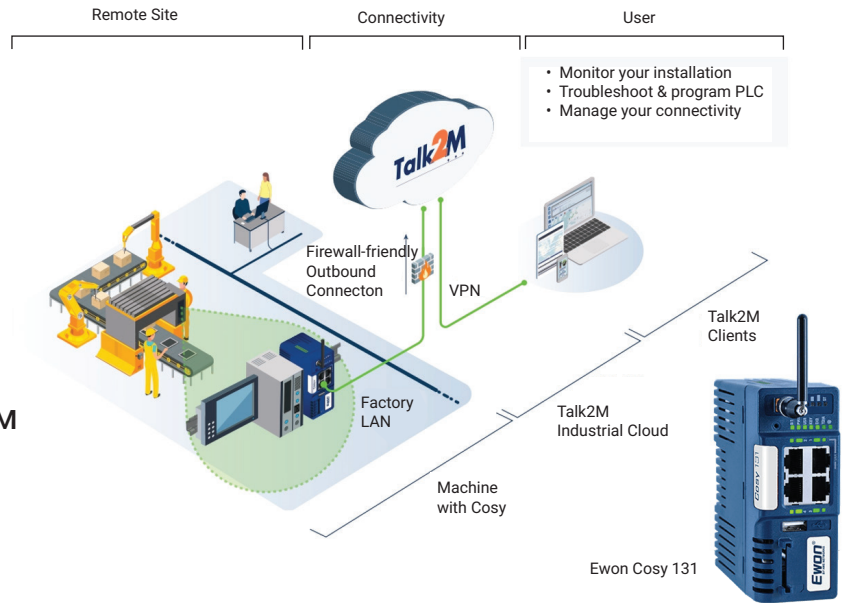

Ewon Flexy- IIoT Gateway with VPN Connectivity

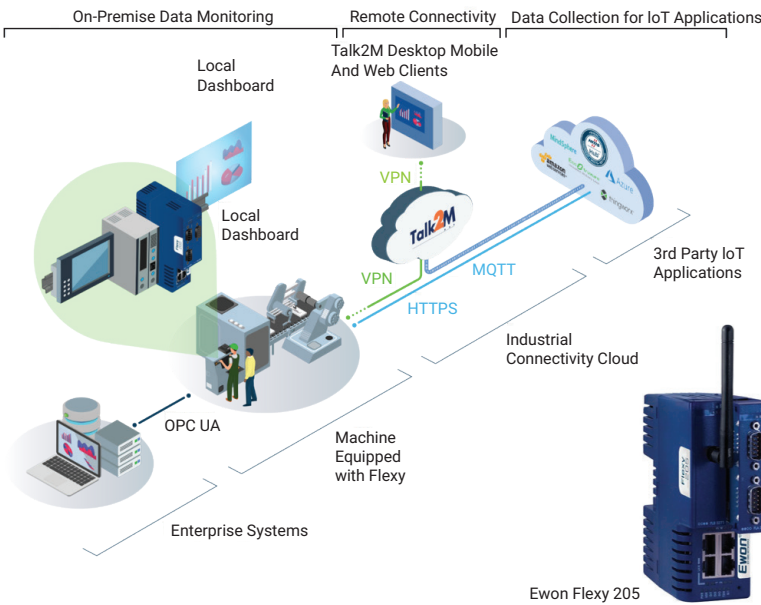

On-Premise Data Monitoring

- All major PLC protocols for data logging and alarm notification
- Local web-dashboard for easy monitoring of KPIs through Talk2M's M2Web service

Remote Connectivity

- VPN Remote Access for PLC troubleshooting
- Talk2M global cloud infrastructure included

Data Collection for IoT Applications

- Full flexibility to send data to any server (local or cloud)
- Multiple IoT connectors, and MQTT/HTTPS through embedded BASIC or JAVA scripting engine

Experience The Next Generation Of Transmitters



Features

- Increased process control through extended diagnostic information
- Flexible workflow using wireless communication
- Temperature Transmitters for in-head and DIN-rail mounting
- App for wireless configuration and monitoring via NFC and Bluetooth
- Loop Powered Isolators and Isolation Transmitters
- ATEX, SIL2 and HART Certified Products
- Made in Sweden, 5 Years Warranty



Clean Room Environment Monitoring System

Cleanrooms or clean zones environment monitoring system is a critical application mainly in pharmaceutical industry where processing or manufacturing is carried out in a controlled environment which means the differential pressure, temperature, and relative humidity of the room must be maintained as per the requirement of the batch/process.

As per Good Manufacturing Practice (GMP) to ensure quality of product and comply regulatory requirement as per US Food and Drug Administration (USFDA) 21 CFR Part-11 guidelines, these parameters values have to be recorded electronically. Under these guidelines, the electronics records and signatures are considered trustworthy, reliable, and generally equivalent to the paper records & handwritten signatures executed on paper. One of the most important aspects of these guidelines are the availability of data, i.e., the system should automatically record data of all parameters and events without fail and under no circumstances manual intervention is allowed.

Masibus, A Sonepar Company provides a state-of-the-art USFDA 21 CFR Part 11 Compliant Clean Room Environment Monitoring System with guaranteed Zero Data Loss from measurement level to the monitoring level, using its own indigenously manufactured CDU (Clean Room Display Units) packaged with AVEVA Plant SCADA and Historian.

The CDU comes in LED/LCD variants having internal/external sensor provisions, wired/wireless external Rh+T sensors. The device comes with full SS front fascia as well as in flame-proof version also as per the nature of requirements of pharma clean rooms. The device is equipped with internal memory which ensures that no data is lost in case of any communication loss with the SCADA system.

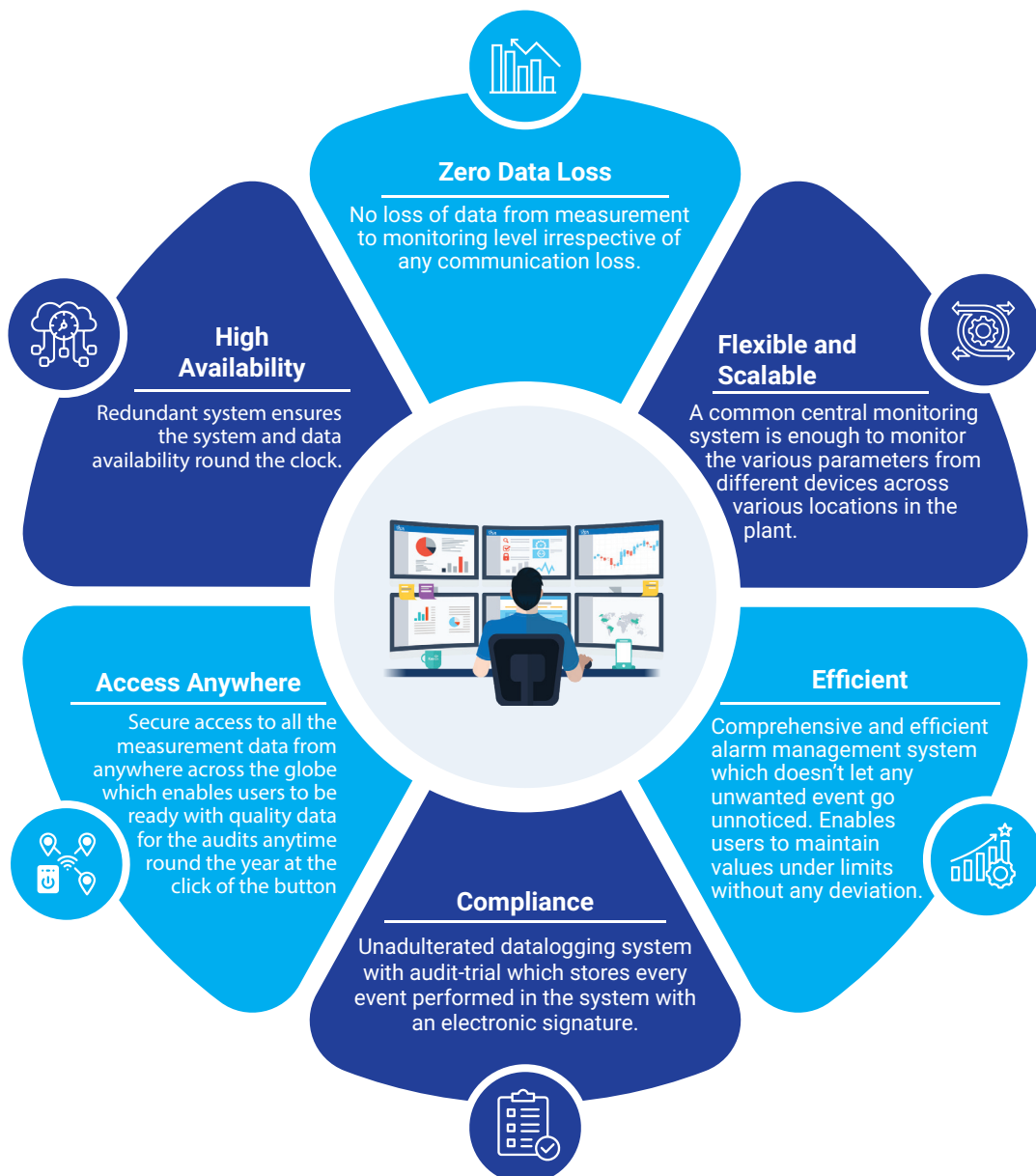



Clean Room Environment Monitoring System

CDU Clean Room Display Unit

Features

- RH, temperature and DP measurement
- Internal sensor option (Ease of installation)
- Remote sensor option for RH+T measurement
- Available in LED and touchscreen TFT LCD display options
- 3 Programmable alarms with visual annunciation
- Data backfilling via DNP 3.0 avoiding data loss



CDU (LED)



CDU (LCD)

HT16Ew Wireless Humidity and Temperature Transmitter

Features

- Temperature & Humidity Measurements -20 to 60° T/ 0-100% RH
- Deep sleep wakeup transmit on 2.4 Ghz ZigBee Wireless
- Zero data loss from device to SCADA with data backfilling
- 12 HT16Ew can connect to one wireless receiver
- HT16Ew with rechargeable battery - 1 year @ 15 min log
- RTC display and synchronization with SCADA
- IP65 Enclosure for protection against dust and water
- Wireless receiver can connect to SCADA on DNP3 Ethernet



FDU



HT16Ew



RH/T External Sensor Probe

Environment Monitoring System

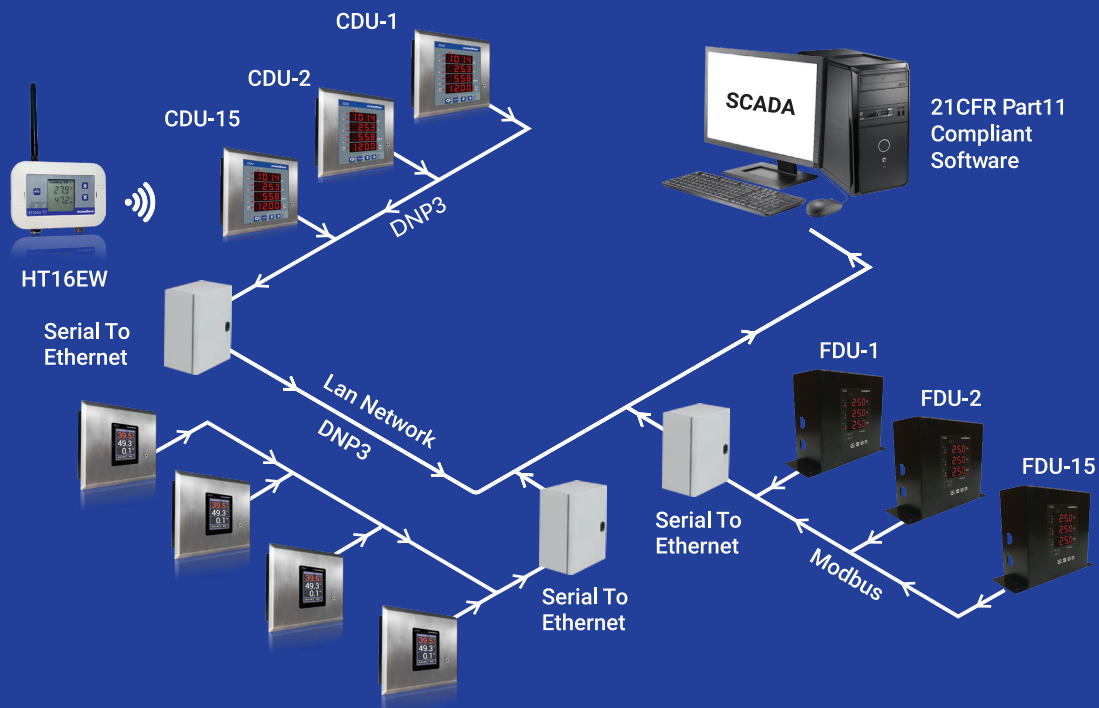

Reactor Automation System

SCADA System
21CFR Comply

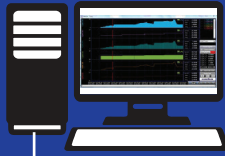

PLC

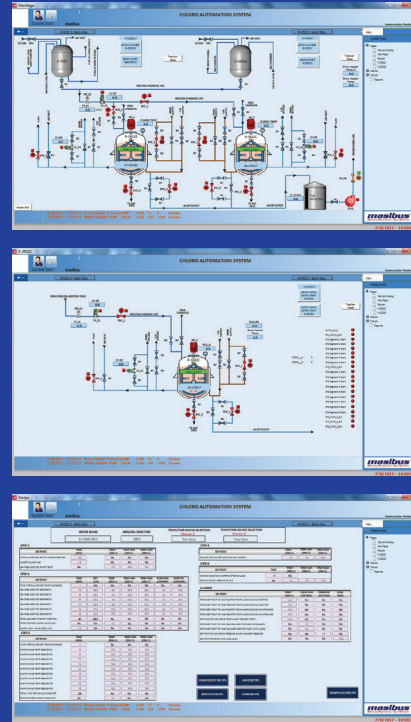
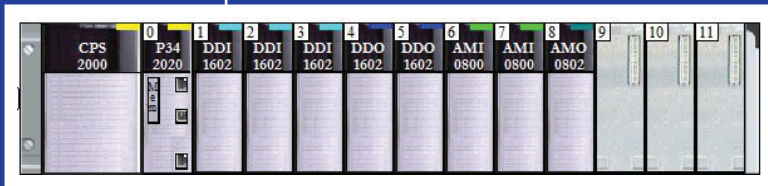

Reactor Automation Benefits

- High productivity
- Less operational cost
- Batch wise reports
- 21CFR Part 11 compliant system
- Alarm and audit trail reports
- Adherence to regulatory needs
- Guidance of quality systems
- Turnkey based solution

Why do you need Reactor Automation Systems ?

To fulfill the requirement of an efficient system that needs continuous process monitoring & control parameters like temperature, utility, pressure, agitator, addition monitoring etc.

Thermography Services

- IR Inspection of MCC / PCC / VFD Panels
- IR Inspection of Furnace Insulation
 - Blast Furnace
 - Reheat Furnace
 - Tempering Furnace
 - ARC Furnace
 - Ladle Furnace
 - Carburizing Furnace
- IR Inspection of High Voltage Transmission & Distribution Line
- Leak Detection & Fault Report
- Hot & Cold Junction Detection & Fault Report

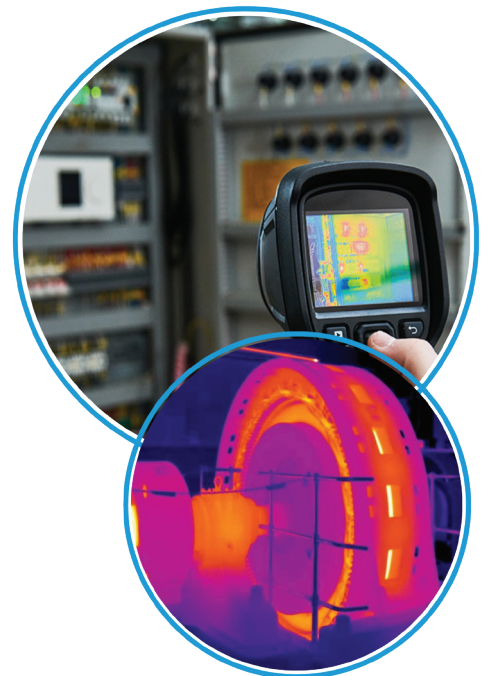
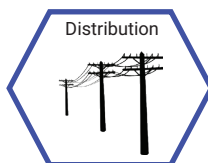
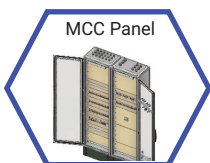



21CFR Enabled SMART Software for Reporting

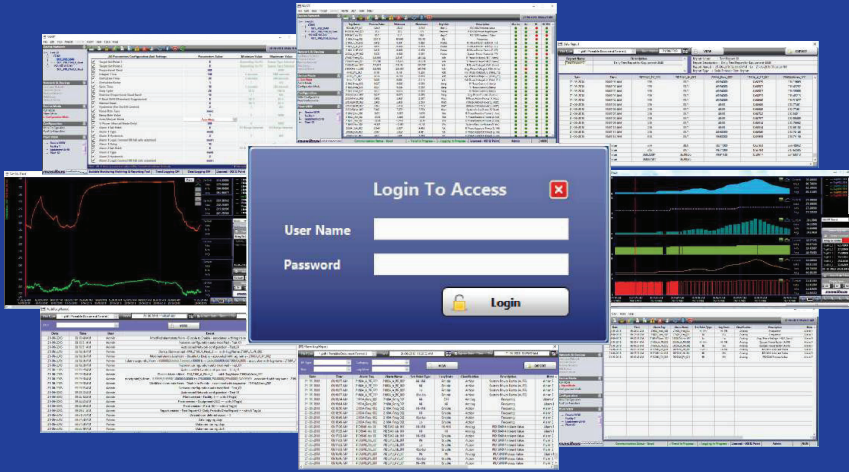

Features

- Online monitoring, data logging and reporting software
- Supports any Modbus devices
- Real time & historic trends display
- Report format supports - Excel/CSV/PDF/DOC/openoffice
- Database supports - MS access/ MySQL
- Licensed software - 64/128/256/512 tags supports

21 CFR Part 11 Compliance Features

- 125+ Audit trails
- Authorization and access control groups upto 5 level
- Electronic signature components and controls
- Protection and ready retrieval of records
- Access security features
- Temper proof data management

Minimum 1 Second Acquisition

Recognize Alarms Instantly (In Red)

Maximum upto 512 Tags

Supported File Format

Displays Trends of Interest

User Defined Channel Grouping

Check Value with the Cursor

Authorized User can only Access

Zoom in/out on both the Scales

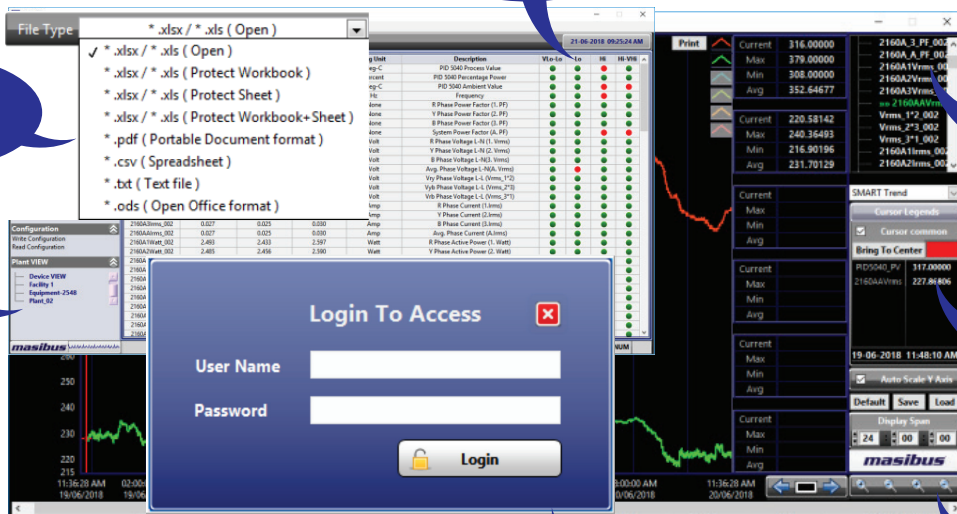



Panel Integration Services

Why Masibus ?

- World class facility with 47 years of experience to stage 170+ panels
- Transparent Business Model (Cost + Contract)
- World class facility to stage 150+ Panels with Remote Access, Testing & Simulation facility
- Fully equipped to conduct IR/ HV tests, I/O test, Voltage adjustment test, Burn-in test, etc.
- All kind of customised Panels, JB and Control Desk with various MOC like CRCA, SS and Aluminium etc.
- Preferred Partner for MNCs

Specializations

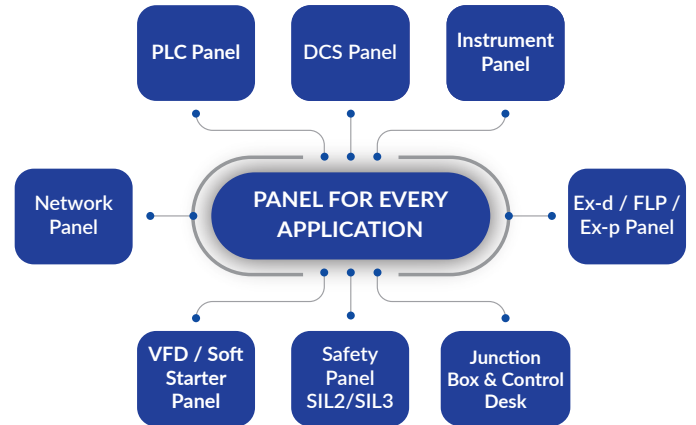

PLC Panel



DCS Panels

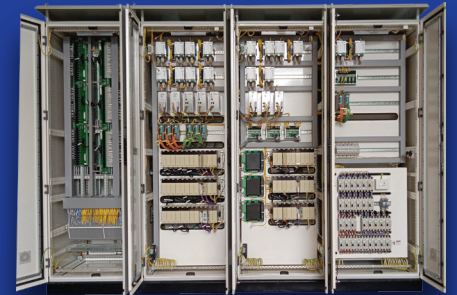

SS Panel



Instrument Panel



Explosion Proof Enclosures



Control Desk



Enclosures



Network Panels





Project Engineering Services

Masibus has 47+ years of experience in Industrial Automation and Instrumentation. Our core competency of Automation, Engineering, and integration helped us to design, install and commission complex automation projects using Citect SCADA, Historian, PLC & IIOT in diverse industries.

Annual Maintenance Contract



We provide cost-efficient AMC services during or after the warranty period to provide quick & immediate access to solutions without emergency breakdowns

Spare Systems



Backup systems as spares allow customers timely solutions during emergency without going through logistical or procurement delays

Services



We provide all types of automation services, online onsite, hourly basis & emergency basis. Based on customer needs to minimize the shutdown time

Training



Enhance technical knowledge on various platforms, Masibus provide certified training programs on SCADA, PLC, DCS & other offered solutions

Software Services for Dashboard & Reports



This is an add-on module on SCADA, where SCADA or any type of database is used to prepare customized dashboards & reports based on customer requirements

Engineer Deputation at Big House



We deliver engineering & project outsourcing services in India & overseas. We provide tailor-made solutions as per our client's needs

OT Integrations



We provide services for OT integration of field sensors to level-2 system (Like PLC, SCADA) & make data available on cloud compatible protocol

Upgradation of the Executed Project



We act as a touchpoint for product & software upgrades as & when they are released from manufacturers; reducing the time spent

Calibration & Validation Services



We provide services for instrument calibration & automation system validation to provide error-free measurement reading

As-Built Drawings Preparation



We have a team of experts puts all of their brains into work to provide you as-built drawing services with the utmost satisfaction

Platform Independent Industrial Automation Competency

Networking Media	Protocol	Hardware	Software
Serial Communication	Modbus, Profibus IEC 101/103, DNP3.0 MELSEC	PLC: Schneider Siemens, Rockwell, GE, Toshiba, Mistubishi	SCADA: Aveva Citect Scada, Wonderware, iFix Wincc Professional AB RS View
Ethernet Communication Cat6, Fiber Optic Wireless (Zigbee, Wifi, GPRS/M2M VPN)	Modbus TCP/IP Profinet Ethernet/IP IEC61850 IEC 104 DNP3.0 OPC DA OPC UA MELSEC NTP/SNMP FINS Bacnet TONs	HMI: Schneider, Siemens, Proface, Beijer, Exor, Delta, Stahl RTU: Schneider PAC System: OPTO22 DCS: Toshiba Remote Monitoring: Ewon Drive: Schneider, Delta, Siemens	Opto22: Groov, PAC Display Database/reporting Tool: Aveva Historian SQL MYSQL MS access Inter PC Connectivity: Cogent Kepware Matrikon
IOT Connectivity	MQTT Restful API Node-RED, HTTP/HTTPS	Opto22 :Groov EPIC Cloud Solution	IIOT Platforms: Datacrew, Altizon Ewon Othertool: MS Project, Autocad

masibus

A Sonepar Company

Masibus Automation And Instrumentation Pvt. Ltd.

Gandhinagar

Address: B-30, G.I.D.C. Electronic Estate, Sector - 25, Gandhinagar - 382 024, Gujarat, India

E-mail: sales@masibus.com

Ph. No.: +91 9662042824

Goa

Address: C-6, Phase 1-A, Verna Industrial Estate, Verna, Salcette - 403722, Goa, India

E-mail: sales@masibus.com

Ph. No.: +91 9822135796

Sharjah

Address: A2-102, SAIF Zone, PO Box 120145 Sharjah, UAE

E-mail: sharjahall@masibus.com

Ph. No.: +971 65574650

Bengaluru

E-mail: sales@masibus.com

Ph. No.: +91 8732971943

Chennai

E-mail: sales@masibus.com

Ph. No.: +91 9725154195

Delhi

E-mail: sales@masibus.com

Ph. No.: +91 9909949742

Hyderabad

E-mail: sales@masibus.com

Ph. No.: +91 9909949062

Kolkata

E-mail: sales@masibus.com

Ph. No.: +91 9512003359

Mumbai

E-mail: sales@masibus.com

Ph. No.: +91 9689937234

Pune

E-mail: sales@masibus.com

Ph. No.: +91 9689937234

E-mail: sales@masibus.com
Website: www.masibus.com

Sales Service: TOLL FREE (India)

1-800-233-2273

Sonepar India Pvt. Ltd.

Gurgaon

Address: Plot No. 229/239, Village - Kherki Daula, Sector 76, Gurugram, Haryana, 122004, India

Kolkata

Address: 503, Block 4B, Ecospace Business Park, Newtown, Rajarhat, Kolkata, West Bengal, 700160, India

Chennai

Address: Plot No. 1, Gokul Garden, Melnallathur, Thiruvallur, Chennai, Tamil Nadu, 602002, India

Aurangabad

Address: FP-42, Five Star Industrial Area, Shendra MIDC, Aurangabad, Maharashtra, 431201, India

Panchkula

Address: Plot No. 263, Industrial Area, Phase-II, Panchkula, Haryana, 134113, India

Bhubaneswar

Address: Plot No. 443, 1st Floor, Saheed Nagar, Bhubaneswar, Odisha, 751007, India

E-mail: communications@soneparindia.com
Website: www.soneparindia.com