

masibus
A Sonepar Company

Data Acquisition



DAQ Products

Masibus DAQ Range of Products



AI-4 CH



AI-8 CH



AO-8 CH



DI-16 CH



DO-16 CH



MSC-ZB-RS



85XX+



8208

IO Cards for IIoT & PLC/DCS (MINT)

Wireless Products

Scanners & Data Loggers

DAQ
Products

Protocol Converters

IoT Gateway

Solar String Monitoring Module

Data Acquisition Software



8204



8040



MSC-ME-MS



HT16u



MSC-PS-MS



MSC-ME-ZB



HT16Ew

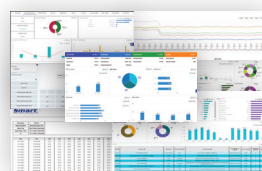

SMART 2.0 Software



MSG-21



SBM-S-1225

All Masibus DAQ & other Products are IIoT Ready

What is IoT?

The Internet of Things (IoT) describes the network of physical Objects/Things-that are embedded with sensors, software, and other technologies for the purpose of connecting and exchanging data with other devices and systems over the internet.

IoT Application can be classified broadly in Commercial & Industrial Domain as below

Consumer IoT

Consumer IoT solutions are focused on individual users or families through the use of wearables (e.g. Smart Watch), smart home applications, and personal monitoring/assisting devices (e.g. Mobile Phone). A suitable example are voice smart assistants such as Amazon's Echo, Google's Home, and Apple's HomePod; in other words, products that make our lives easier by performing tasks or services for us, It's the network of connected devices and systems that can communicate and exchange data with each other.

Industrial IoT (IIoT)

Unlike Consumer IoT, Industrial IoT targets existing automated industrial systems looking for dramatic improvements in productivity and efficiency. The most common IoT requirements comes from large scale factories or manufacturing plants, IoT also comes into picture for monitoring utilities and expensive assets. The IoT and IIoT ecosystem is growing and will keep growing more than exponentially in future . For this reason, we have to make sure that we choose the right products with suitable connectivity and functionality for our solutions in order to bring the sensor data to the supervisory level for suitable monitoring and decision making , the product should be having scalability feature to integrate more device in future with proper industrial handshaking & protocol.

Automation Pyramid

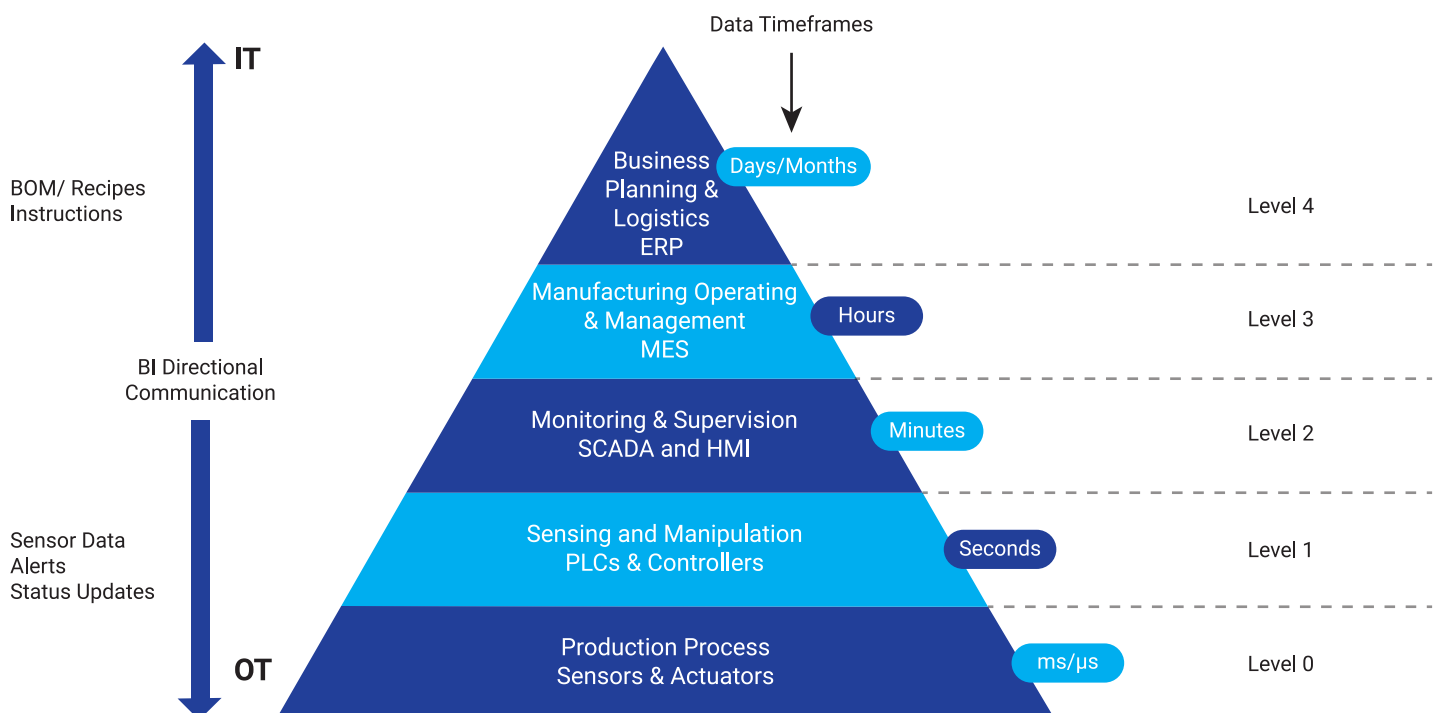

Industrial Internet of Things (IIoT)

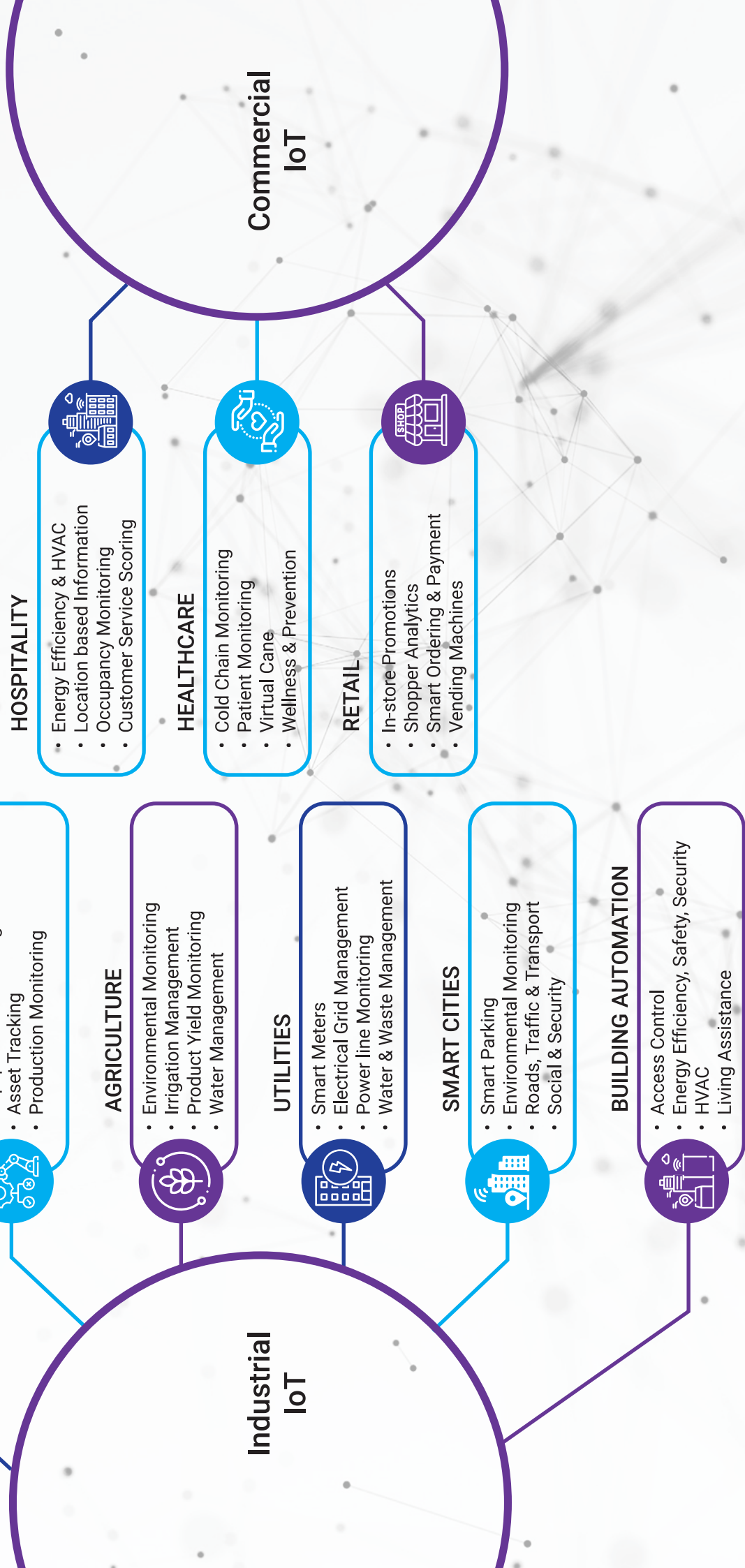

I/O Cards from Masibus (MINT)



Analog Input



4 CH

Analog Input



8 CH

Analog Output



8 CH

Digital Input



16 CH

Digital Output



16 CH





MINT IO's comes with below different options

- 1 RS-485 Port
- 1 RS-485 + Ethernet Port
- 2 RS-485 Port

Protocol support - Modbus RTU
Modbus TCP I/P

Can be connected with any make of PLC-CPU as I/O Card

Can be connected as Data Concentrator/Collector for IIoT Application

MINT IOs					
Model	4-AI	8-AI	8-AO	16-DI	16-DO
Channels	4	8	8	16	16
Type	Voltage/Current (Fix)	RTD/TC/ Voltage/Current (Universal)	Voltage/Current	24V DC input	Open collector 24VDC sink/ source 100mA per O/P
Isolation	Supply to field: 1500VAC RMS, Supply to RS-485: 1500VAC RMS, Field to logic: 1500VAC RMS				
Scan Time	50ms/ Ch.	RTD-100ms/Ch. Other-50ms/Ch.	All 8 Ch. in <500ms	500 µs	Configurable
Resolution/ Accuracy	16 bit ADC 0-1 %	16 bit ADC 0.1%	16 bit DAC 0.05%	1 KHz 32 Bit Counter	10ms Pulse O/P

PLC with IOs on RS-485 - Modbus RTU

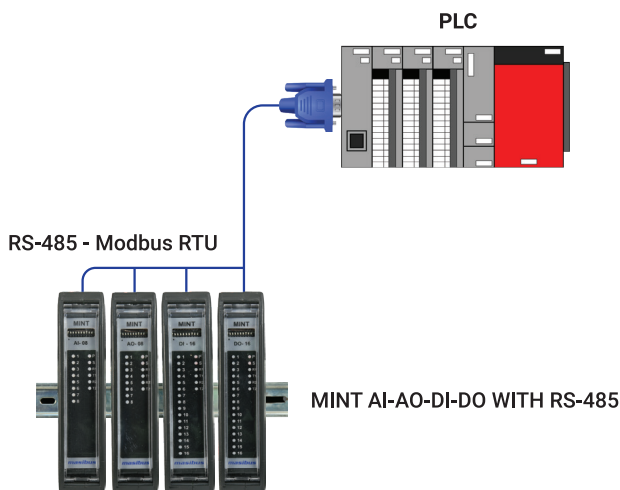

Mint CP with I/O on Modbus TCP/IP to PLC & Mint IO's to HMI on RS-485-Modbus

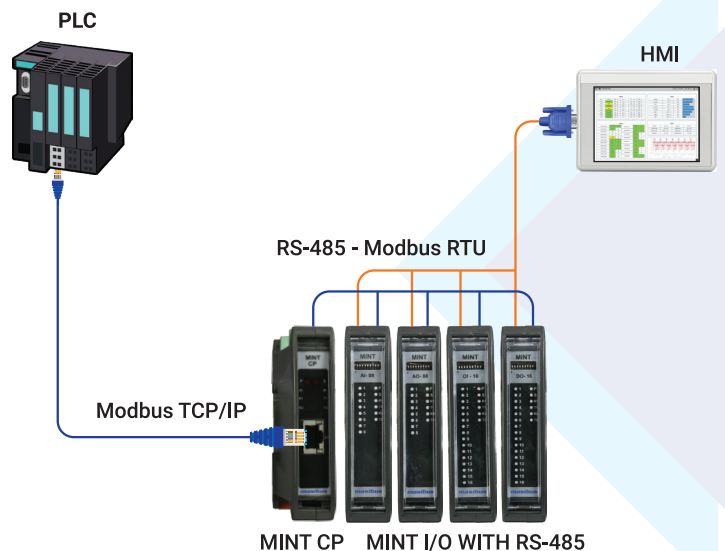

Application Examples

PLC/HMI as Multiple Clients Connect to MINT Ethernet IO on Modbus TCP/IP

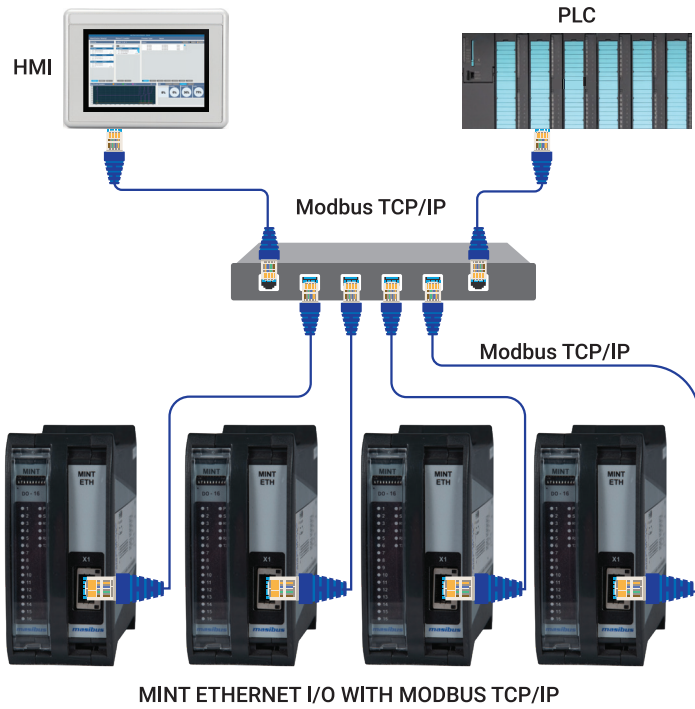

MINT IO's to HMI on RS-485-Modbus

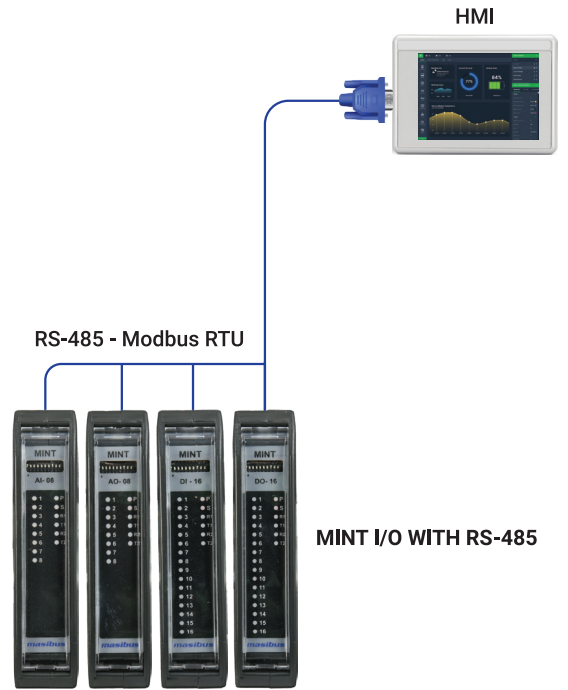

PLC with IOs on RS-485 - Daisy Chain

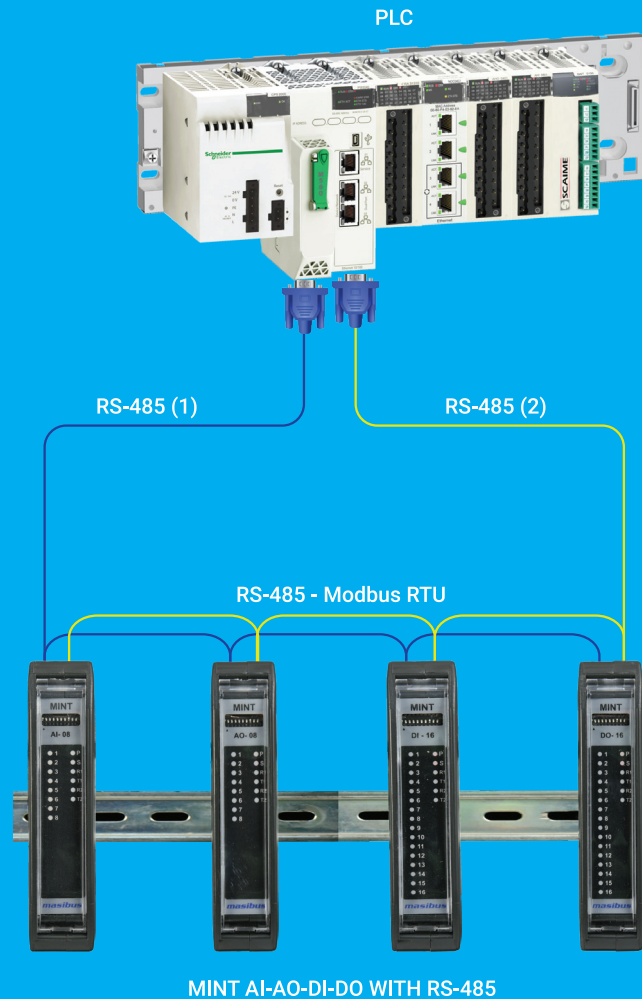

Application Examples

Communication Processor for MINT I/O



MINT-CP

Performance	
Maximum No. of Read Registers	1024
Maximum No. of Write Registers	1024
Maximum No. of Modbus Commands Supported	100
No. of Slave Devices Supported per Serial Port	No. of Modbus devices supports on serial port - 15
No. of Clients Supported on TCP/IP	Up to 15
Communication	
RS-485 Serial Port	2 Nos.
Protocol	Modbus-RTU slave
Ethernet Port	1 Nos.
Protocol	Modbus TCP/IP (Modnet)

Configuring MINT I/O as Redundant I/O System

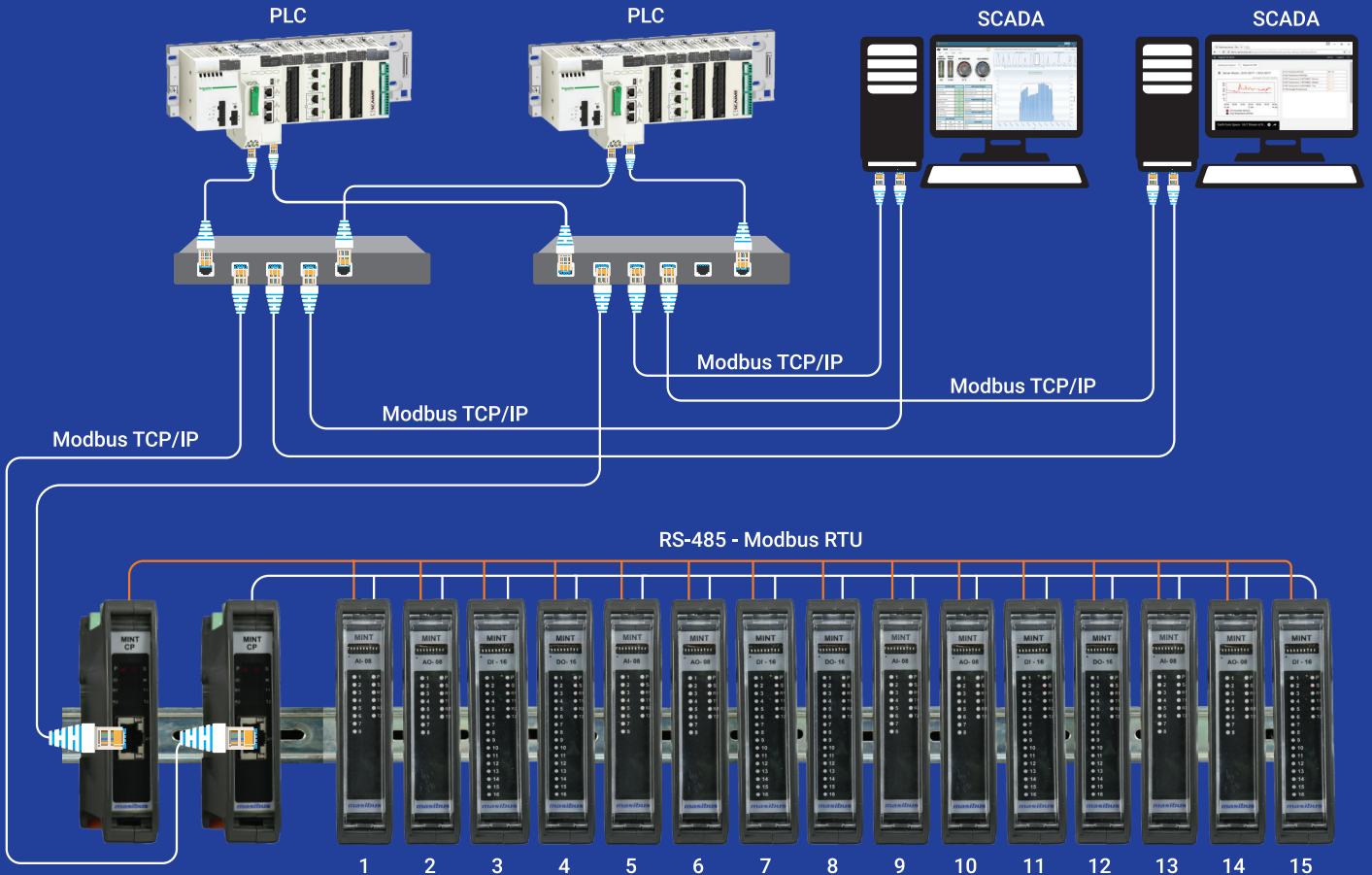

Application Examples

MINT-DI as 1 KHz High Speed Counter

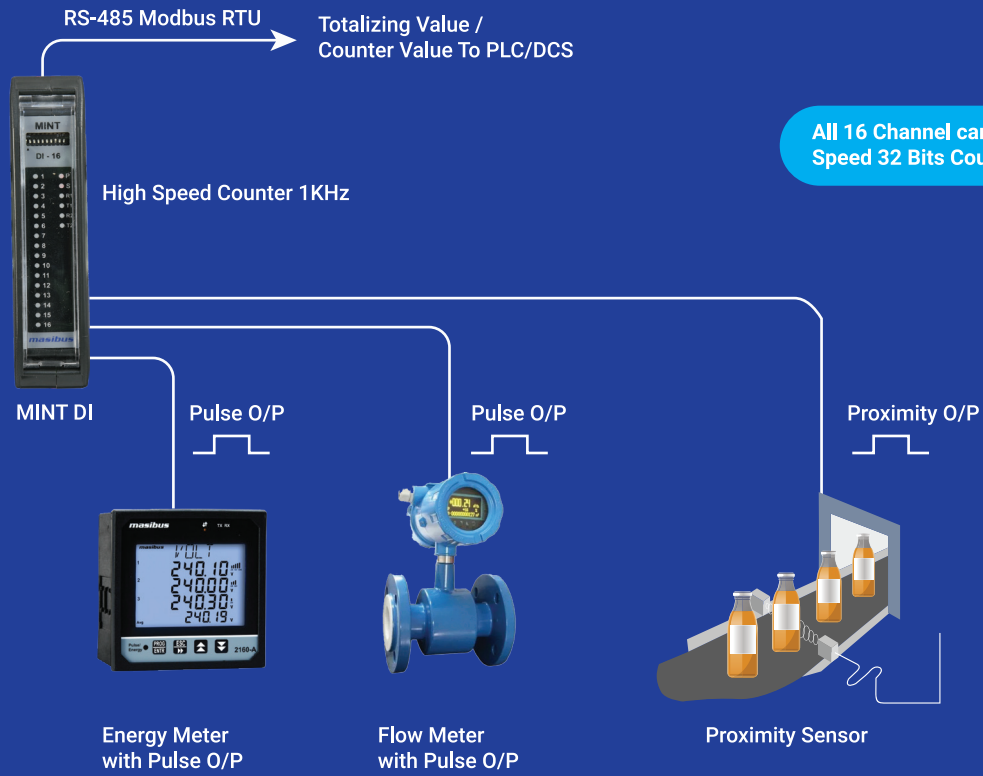

All 16 Channel can be configured as High Speed 32 Bits Counter of Frequency 1KHz

Configuring a larger I/O System with MINT I/O

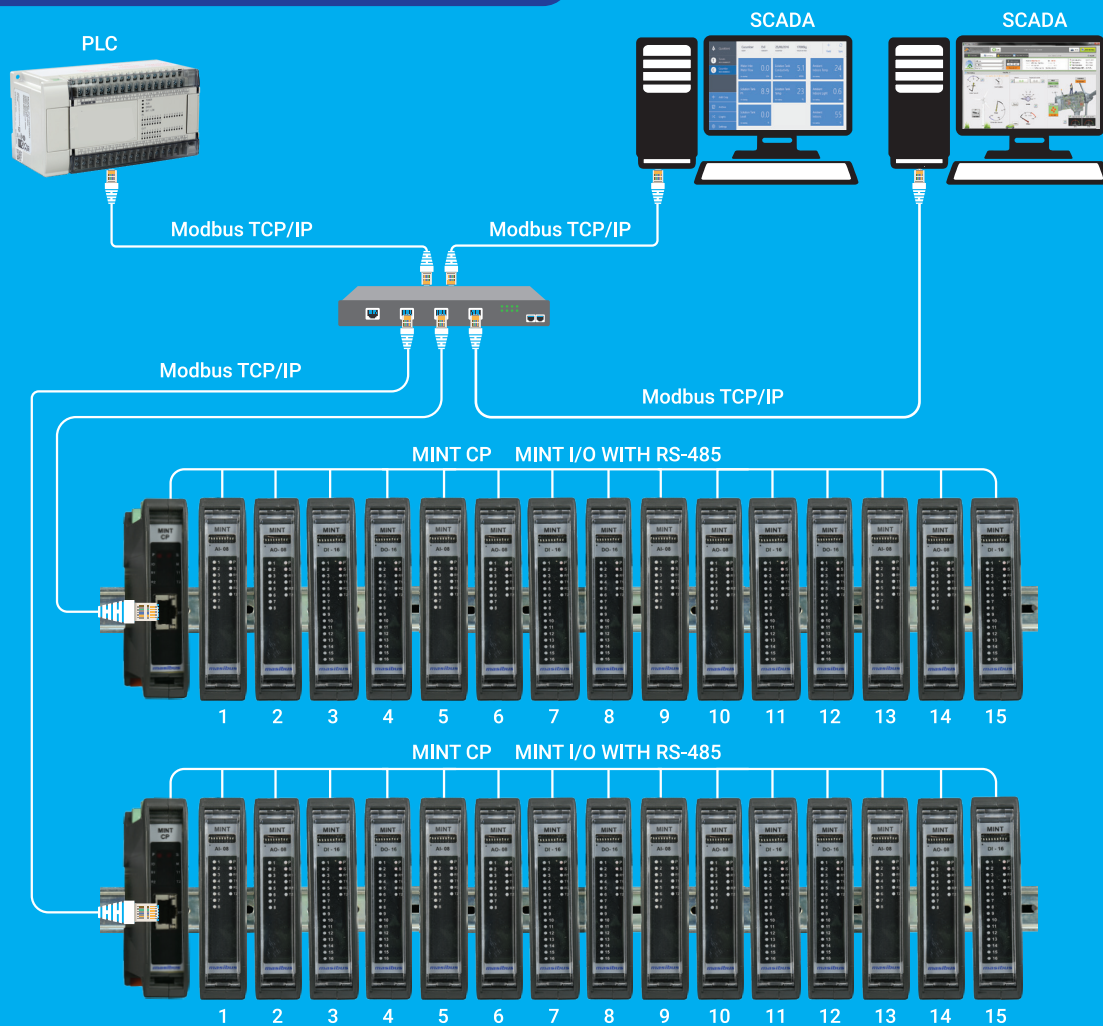

Reproducing AI & DI Signal for a Long Distance Transmission Concept of I/O Pair for DI & AI Signal for PLC & DCS System

I/O Pair for Analog Input

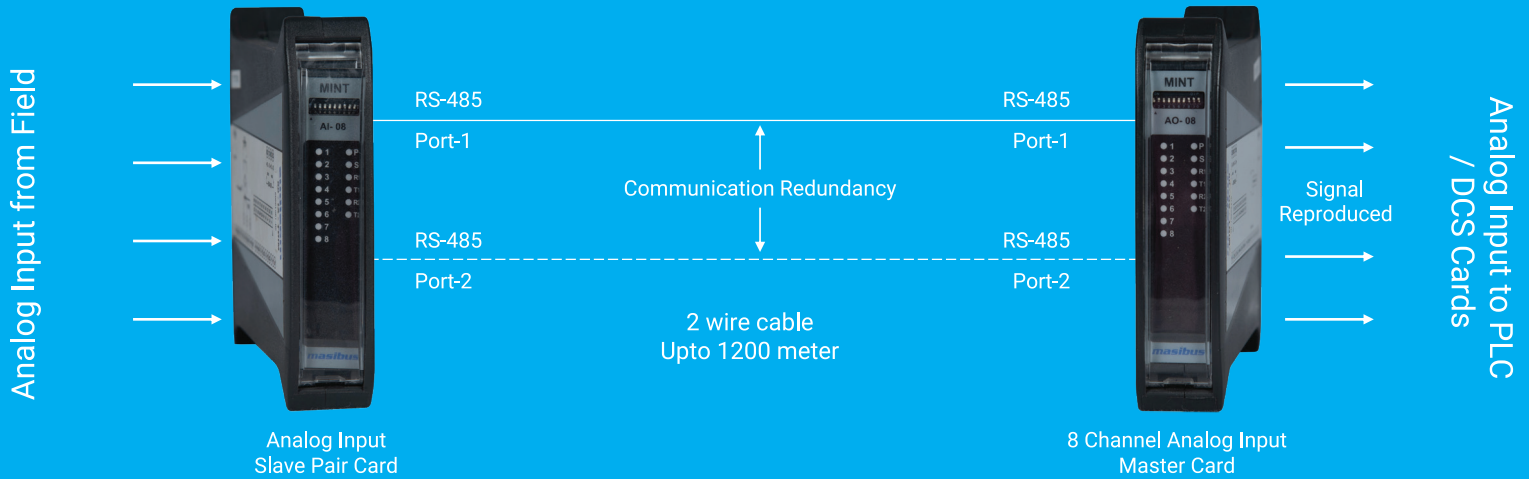

I/O Pair for Digital Input

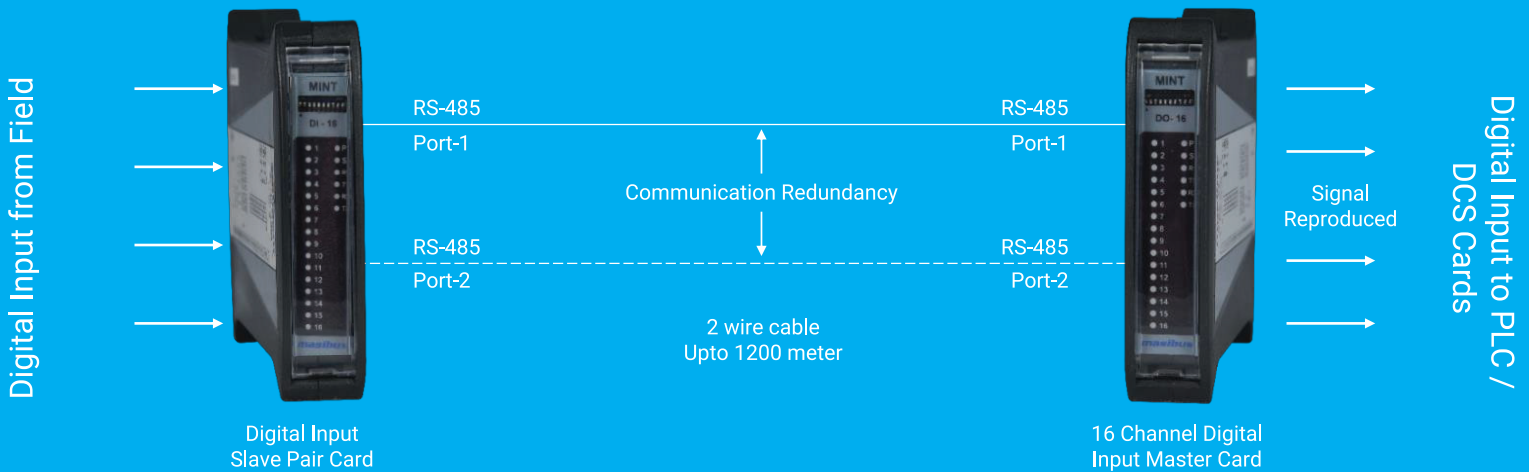

- 8 Channel Analog Input master-slave pair
- 16 Channel Digital Input master-slave pair
- Works with any PLC/DCS make
- Plug & play solution
- Reduces the cable cost for field signals
- Channel density can be increased or decreased if required

- Communication redundancy possible with 2 pair of dedicated RS-485 port
- No programming is required
- Master slave pair reproduces the signal from remote end to central PLC / DCS end upto 1200 meter a part



8204
(4-Channel Scanner)



8208
(8-Channel Scanner)



85XX+
(8/16/24-Channel Scanner & Data Logger)



8040
(128-Channel Data Logger)



8208-IP
(8-Channel Weather Proof Scanner IP-65 Enclosure)



8208-XP
(8-Channel Ex-Proof Scanner for Hazardous Areas)

Scanner & Data Logger

Scanner & Data Logger							
Model		8204 4-Ch. Scanner	8208 8-Ch. Scanner	85XX+ 8/16/24-Ch. Scanner & Data Logger	8040 128-Ch. Data Logger	8208-IP 8-Ch. Weather Proof Scanner IP-65 Enclosure	8208-XP 8-Ch. Ex-Proof Scanner for Hazardous Areas
Input	AI	4	8	8/16/24	16 to 128	4/8	4/8
	DI	-	-	16	-	-	-
Output	RL	4	4	8/16	16	4	4
	OC	-	-	24	32	-	-
	AO	1	1	8	-	1	1
Serial Port RS-485		1	1	2	2	2	2
Ethernet (ModbusTCP)		-	-	1	1	-	-
Profibus DPV0		-	-	1	-	-	-
USB Pendrive Port		-	-	1	1	-	-
Input Scan Time		1 Sec.	1 Sec.	1 Sec.	3.2 Sec.	1 Sec.	1 Sec.
Internal Data Log Memory		-	-	32 MB	32 MB	-	-
Isolation		Power to Field 1500VAC Field to Communication 1500VAC Power to Communication 1500VAC			Channel to Channel 125VAC/300VDC Power to Field 1500VAC Field to Communication 1500VAC Power to Communication 1500VAC	Power to Field 1500VAC Field to Communication 1500VAC Power to Communication 1500VAC	
Enclosure		ABS 1/8 DIN mount	ABS 1/4 DIN mount	Steel Sheet Powder Coated	19' Sub-Rack	Steel Sheet Powder Coated IP65	Aluminium Alloy LM-6 Gas Groups IIA & IIB, IP65, Zone: 1, 2 Optional IIC
Connections		Screw Terminals	Screw Terminals	Prefab Cables & Field Interface Module (Option) 	Prefab Cables & Field Interface Module (Option) 	Cable Gland	Cable Gland

Application Examples

Motor Current, Temperature Monitoring & Control

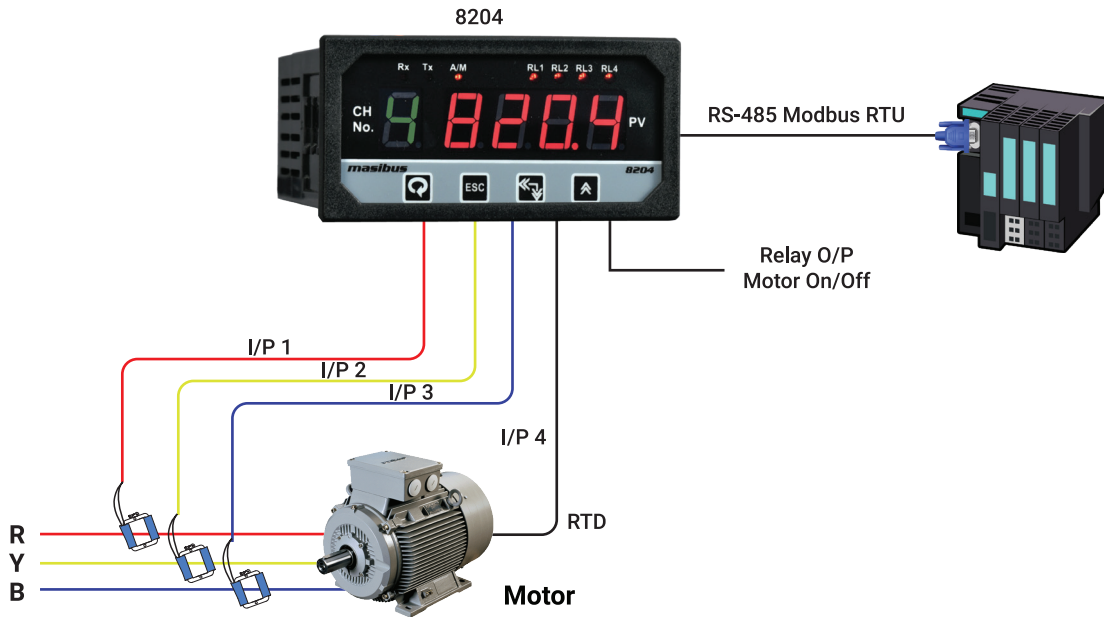

Berrel Zones Temperature Monitoring & Heater Control for Plastic Extrusion Machines

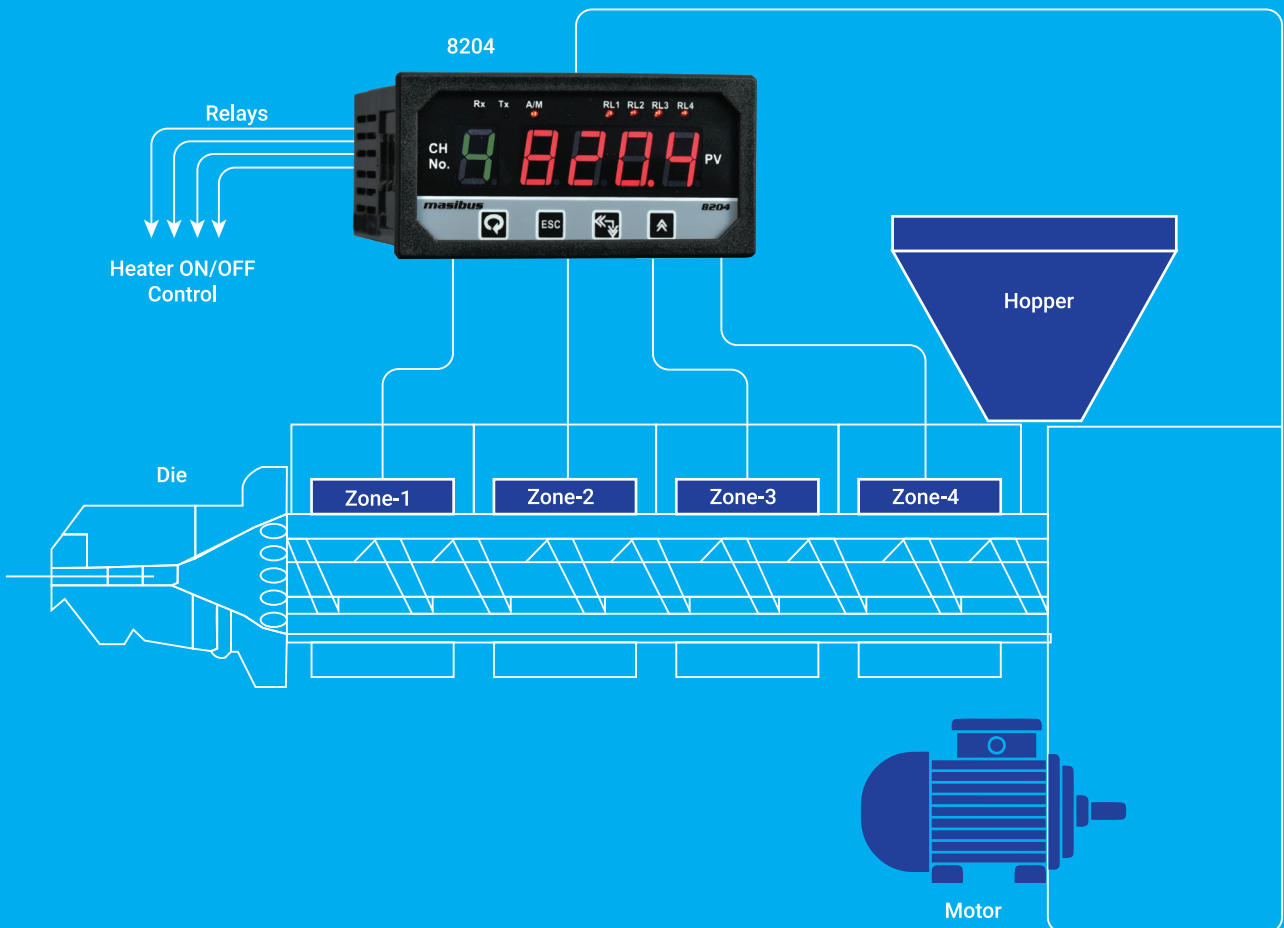

Application Examples

8208-IP as Transformer Protection Relay

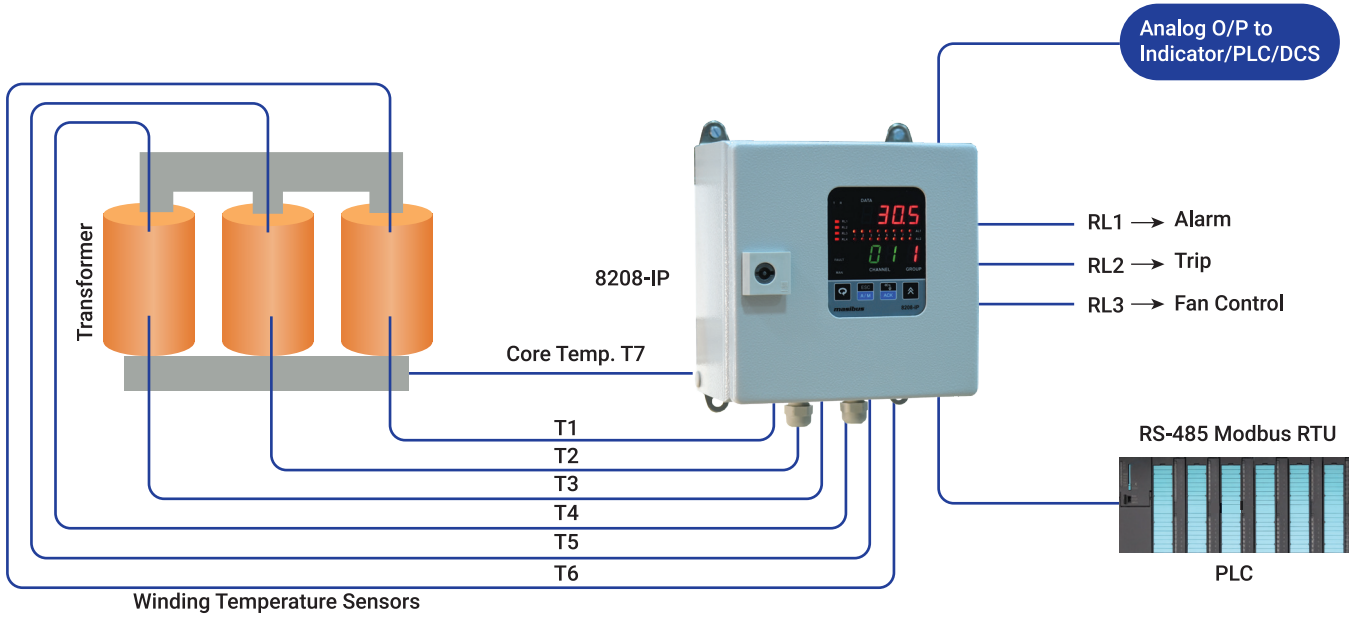

Motor Temperature Measurement & Protection

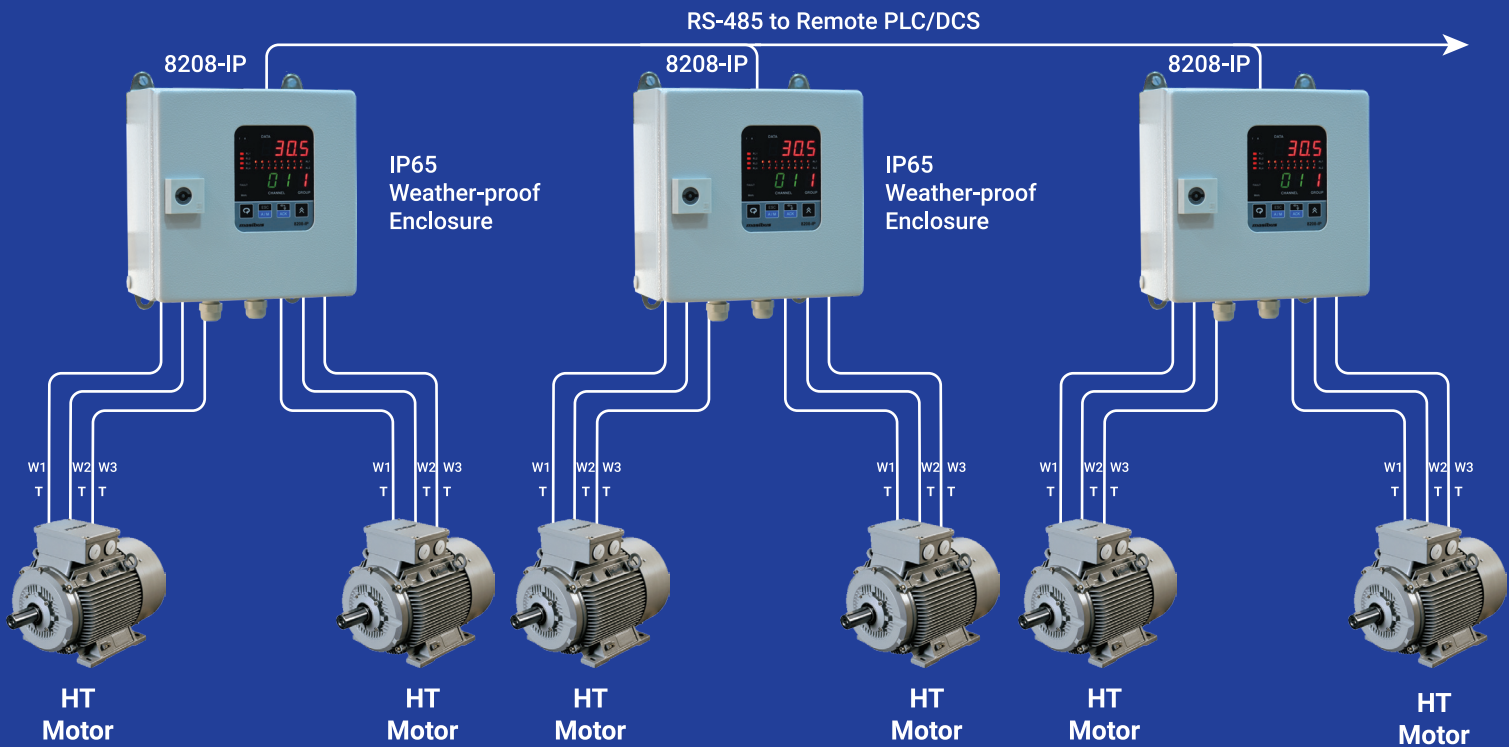

Application Examples

Motor Temperature Measurement and Protection

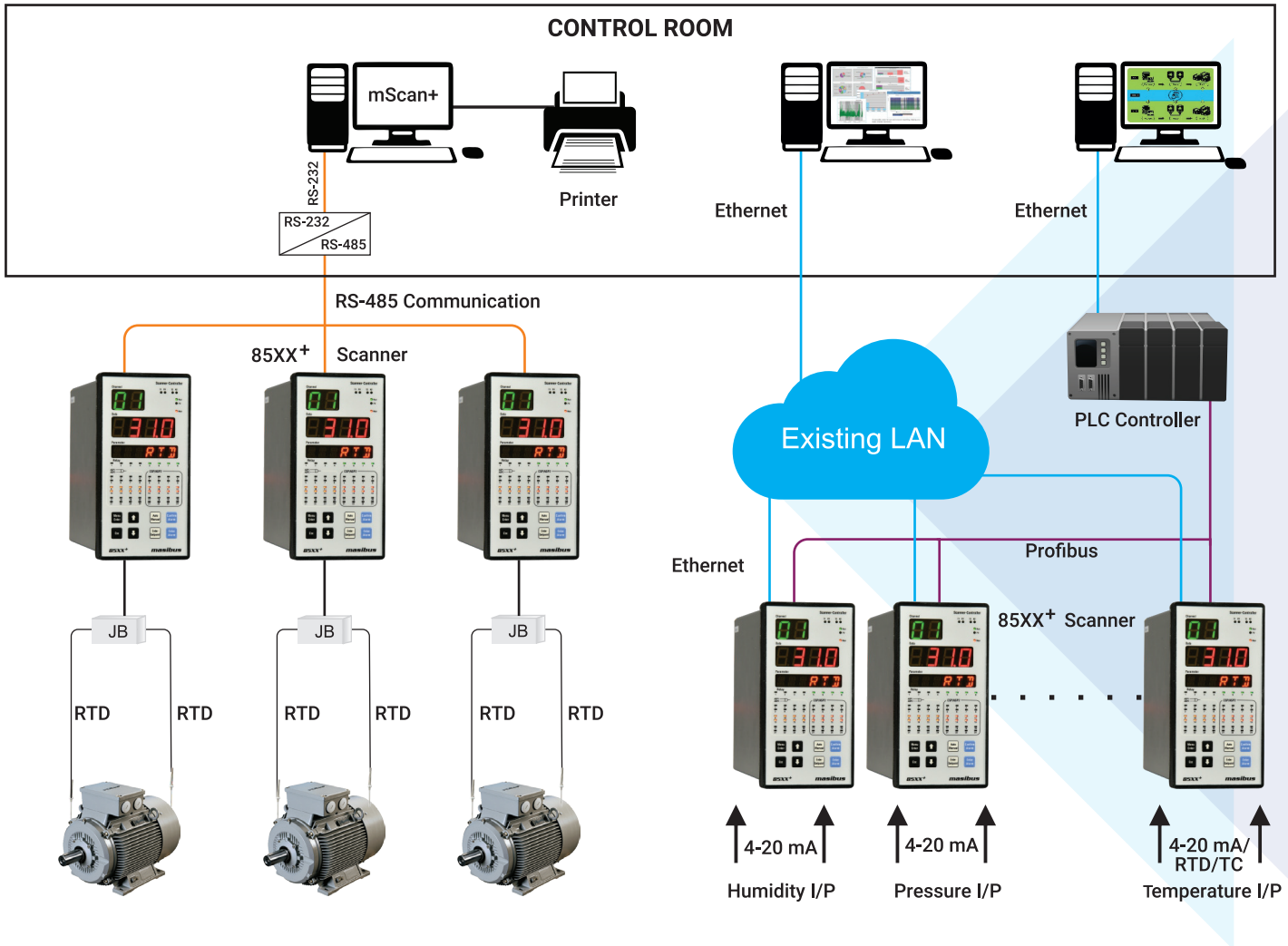

85XX+ as 24 Channel Analog I/O Module for any PLC/DCS

It can eliminate 3 RTD/ 3 Thermocouple & 16 Ch. DO PLC I/O Cards



Busbar Junction Temperature Monitoring for Preventive and Predictive Maintenance of LT Distribution Panels

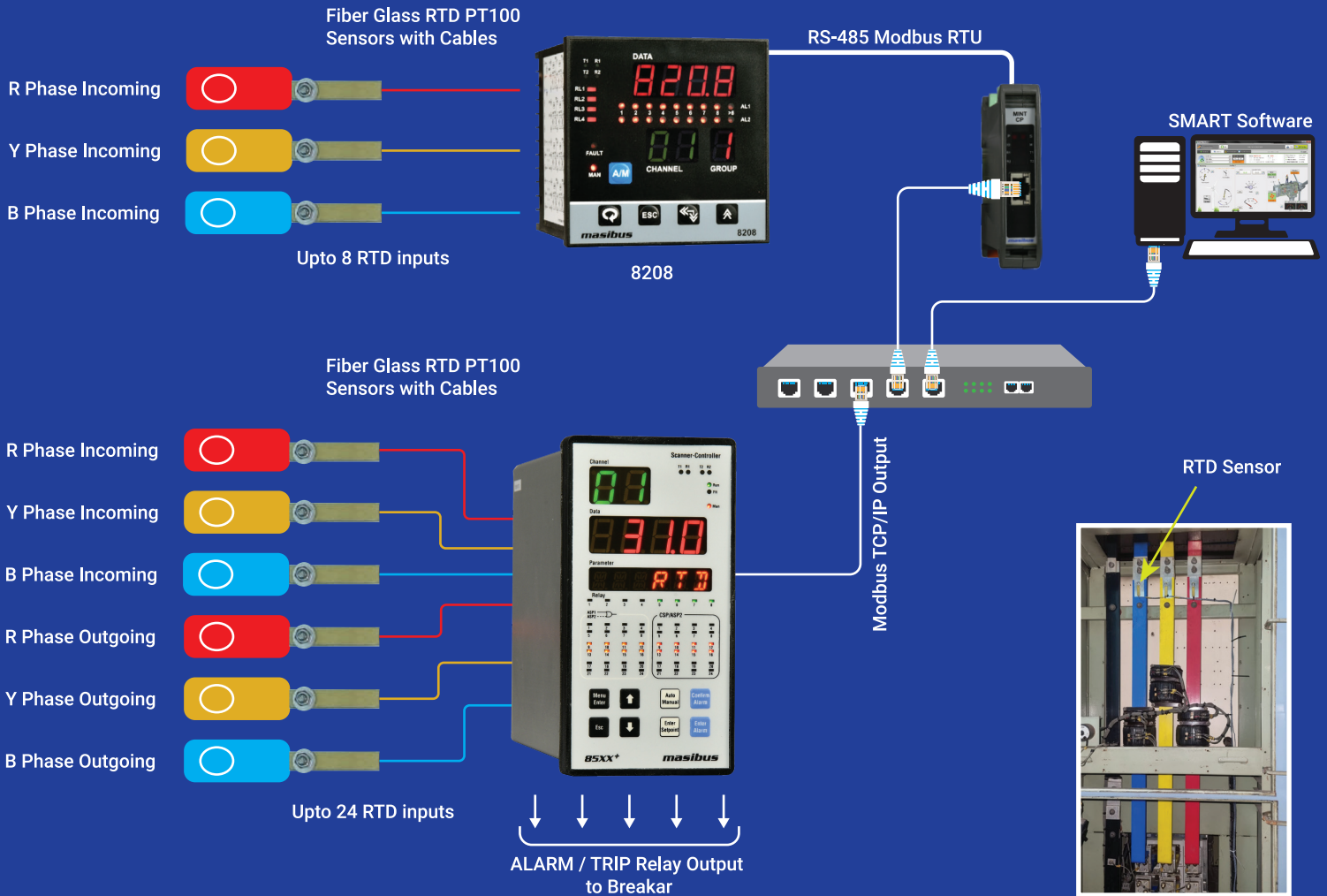

Configuring 85XX+ for 16-Digital Inputs 8-Relay Outputs & 24-Analog Inputs

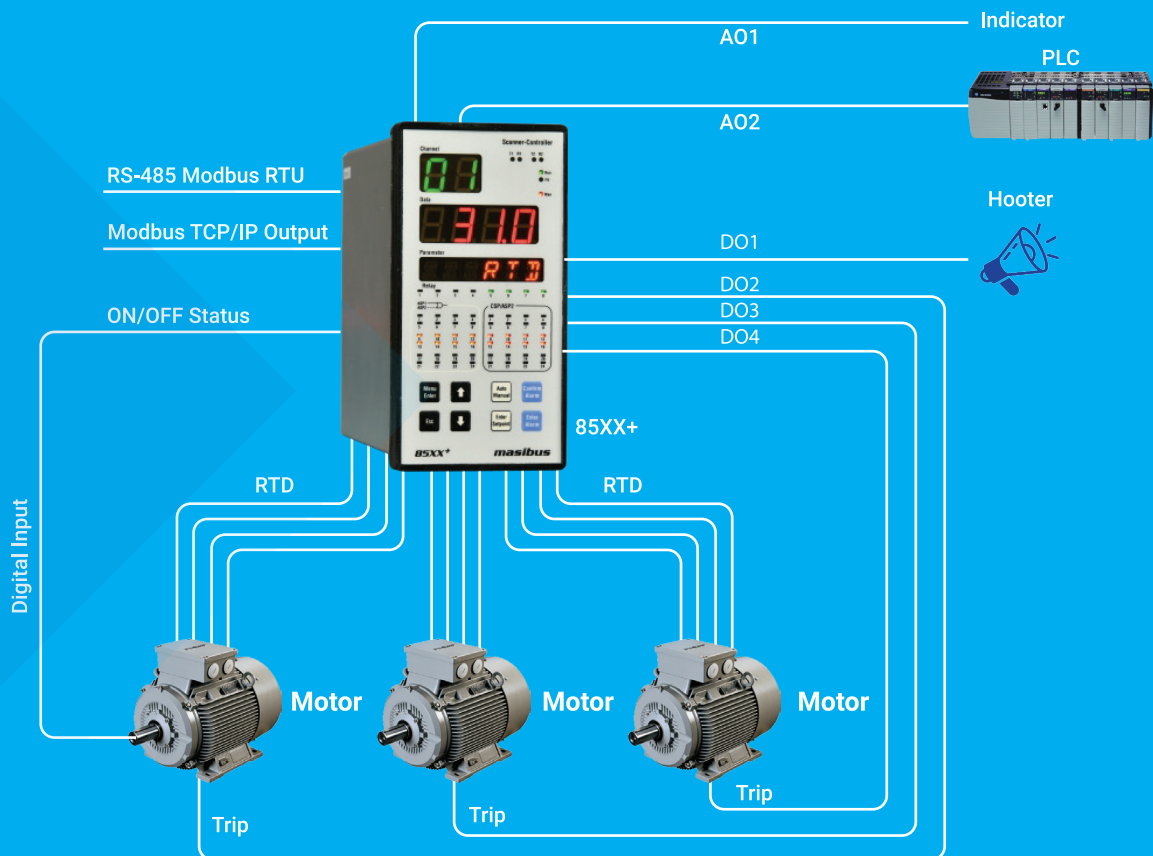

8040 Data Logger Applications



8040

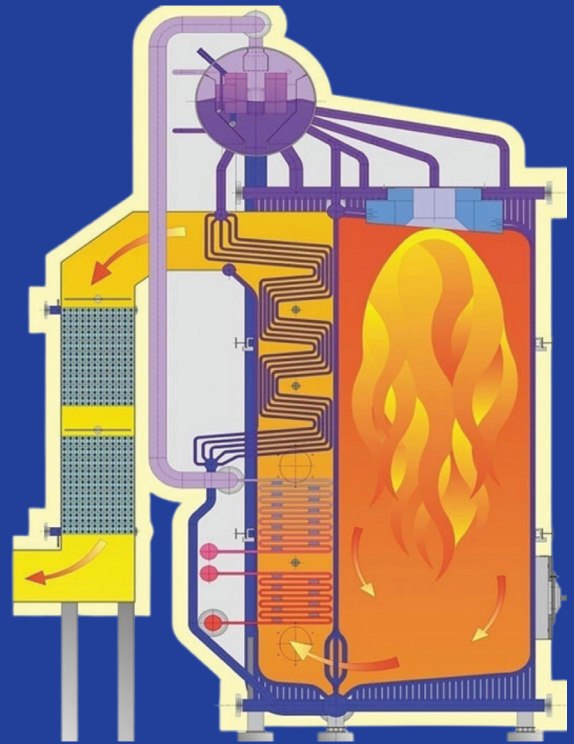

Boiler

Benefits

- 128 Channel Universal Input
- Channel to Channel Isolation
- 3 Second update rate
- 32 MB Internal Memory
- Periodic & Event based Data Logging
- RS-485 & Ethernet Communication Port available

Boiler Tube Temperature Monitoring System

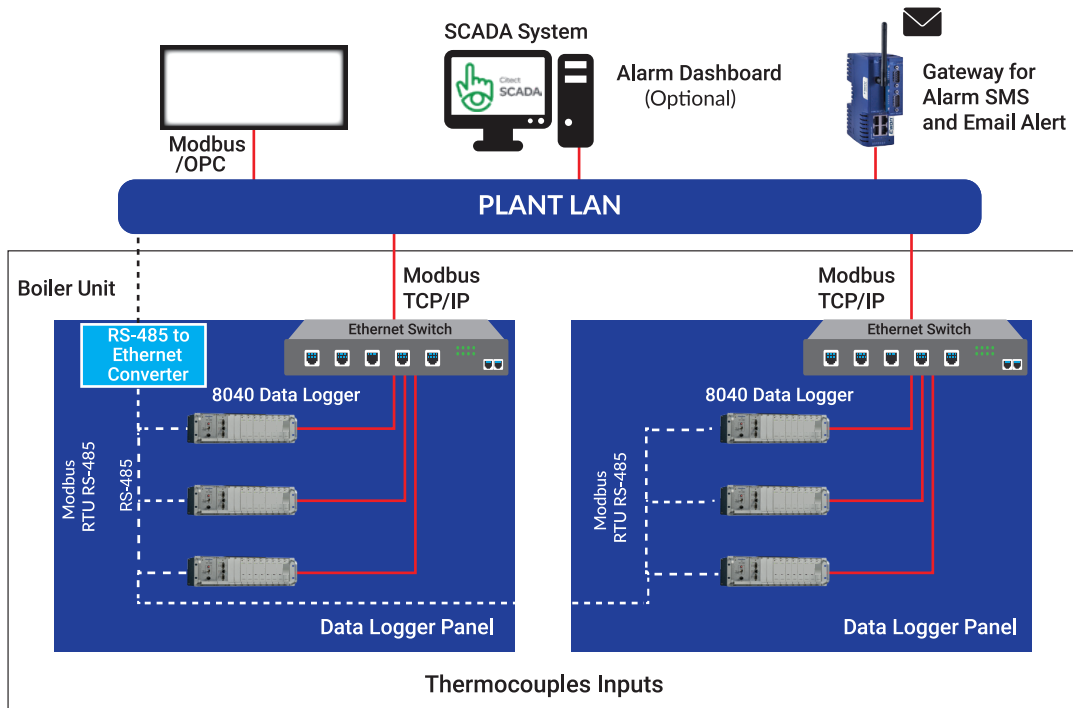

Avoid Unscheduled Outage

Availability & Tube Life

Reduce Secondary Damage

Identify Inefficient Heat Transfer

Increase Operating Profit

Plug & Play Solution

Easy Integration with Third Party System

High Price Performance Index

Application Examples

8040 as 128 Channel Analog I/O Module for DCS/PLC

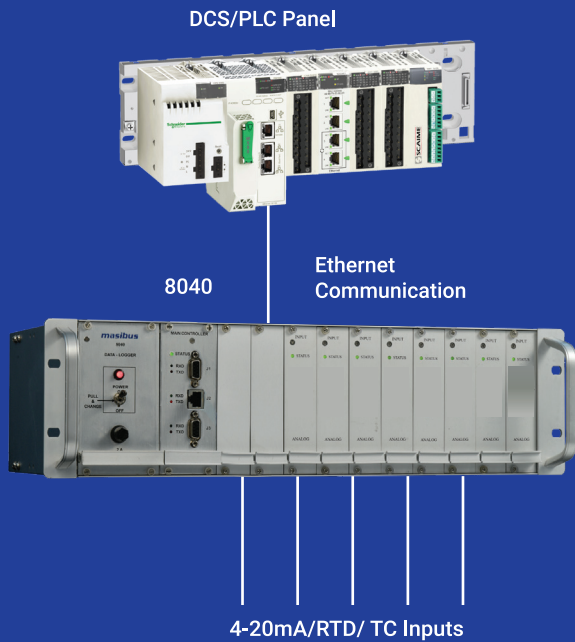

- It eliminates 16x8=128 channel AI card & associated power supply, rack, panels from DCS Panel
- Cost saving approximately 1 million INR

Current & Temperature Monitoring of Multiple Motors in a Plant

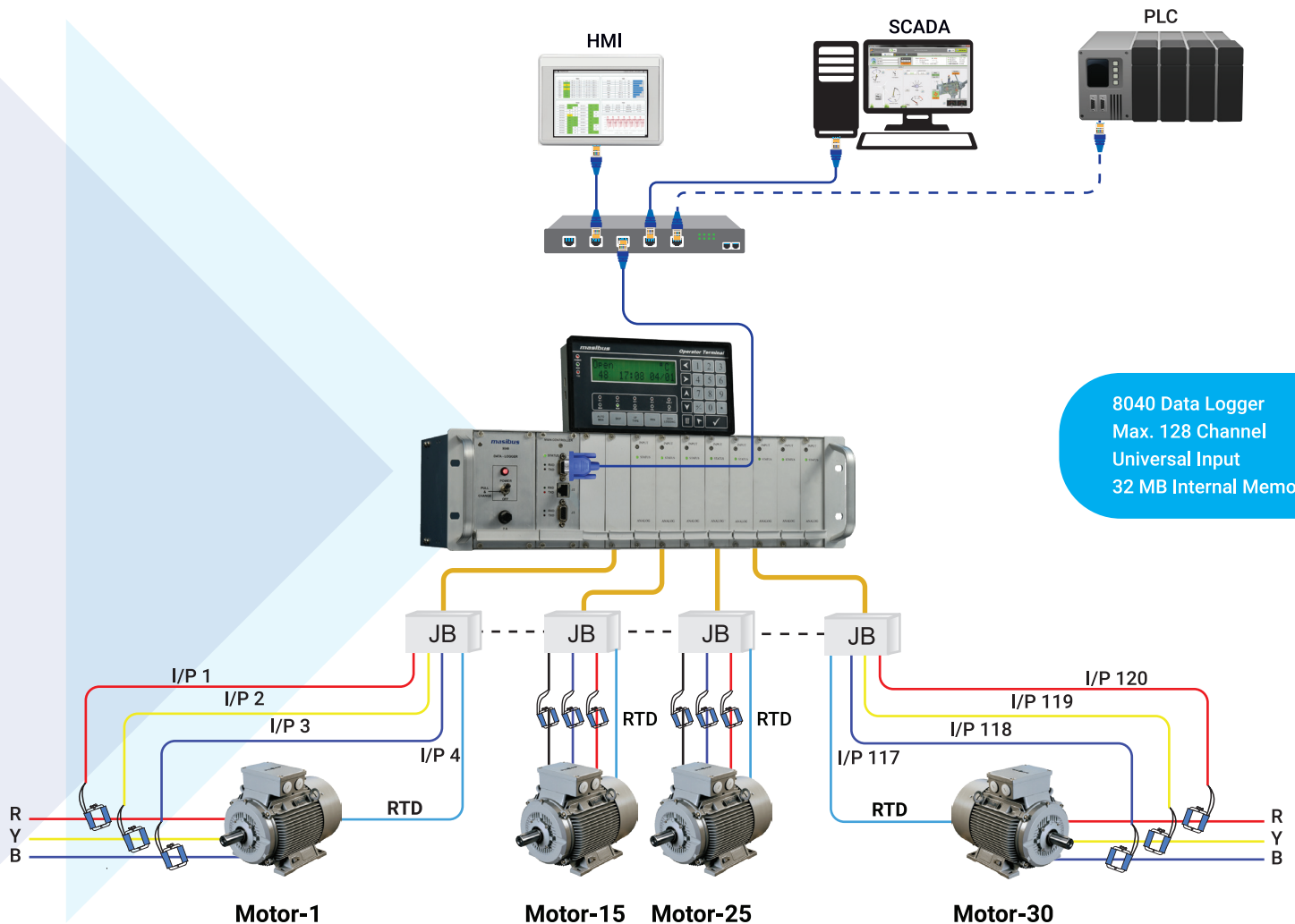

- 8040 Data Logger
- Max. 128 Channel
- Universal Input
- 32 MB Internal Memory

Protocol Converter & Wireless Products



MSG-21
(IIoT Gateway)



MSC-ME-MS
(Modbus Serial to Modbus
TCP/IP Data Concentrator/Gateway)



MSC-ME-ZB
(Modbus-Zigbee to Modbus
TCP/IP Data Concentrator/Gateway)



MSC-ZB-RS
(RS-485 Serial to ZigBee
Wireless Converters)



HT16u
(Humidity-Temperature
Smart Logger)



HT16Ew
(Wireless RH-T Transmitter)



RH/T External
Sensor Probe



SBM-S-1225
(08-12-16-20 String Box Monitor)



MSC-RS-RS
(Isolated RS-485 to RS-485 Repeater)



MSC-RE-RS
(Modbus Serial to Modbus
TCP/IP Protocol Converter)



mUSB232
(USB to RS-232 Converter)



mUSB485
(USB to RS-485 Converter)

Zigbee Offerings

What is Zigbee ?

Zigbee is a wireless technology developed as an open global market connectivity standard to address the unique needs of low-cost, low-power wireless IoT data networks. The Zigbee connectivity standard operates on the IEEE 802.15.4 physical layer radio specification and operates in unlicensed radio band 2.4 GHz.

Zigbee Protocol Features Include

- Support for multiple network topologies such as point-to-point, point-to-multipoint and mesh networks
- Low duty cycle - Provides long battery life
- Low latency time
- Direct Sequence Spread Spectrum (DSSS)
- Up to 65,000 nodes per network
- 128-bit AES encryption for secure data connections
- Collision avoidance, retries and acknowledgement

Zigbee signal range upto 100 meters indoor and upto 1 KM outdoor with clear line-of-sight (LoS) without obstacles. RF range extension also possible via adding Zigbee repeaters in the existing network (Mesh network)



MSC-ME-ZB
(Modbus-Zigbee to Modbus
TCP/IP Data Concentrator/Gateway)



MSC-ZB-RS
(RS-485 Serial to ZigBee
Wireless Converters)



MSC-ME-ZB

Features

- Supports upto 64 Modbus RTU Slave devices on RS-485 & ZigBee
- Number of Master Ports (Modbus RTU): 1 RS-485 (Wired) & 1 ZigBee (Wireless) - Only one active at a time
- ZigBee Topology: Point-Point/Point-Multipoint/Mesh
- Modbus TCP/IP (ModNet) - 10/100Mbps- Auto detecting
- No. of Client supports on Modbus TCP/IP (ModNet) - Up to 15
- Supports up to 192 commands or 2048 Read/1024 Write Registers on Modbus

MSC-ZB-RS

Features

- Number of Ports: 1 RS-485 (Wired) & 1 ZigBee (Wireless)
- ZigBee Topology: Point-Point/Point-Multipoint/Mesh
- Router/Co-ordinator/Aggregator/Master/Slave configuration through MSC studio
- MSC-ZB-RS (Router/Slave) can connect to MSC-ME-ZB or MSC-ZB-RS (Co-ordinator/Master)
- Wireless range extension possible through router

Application Examples

Connecting 64 Modbus Devices Wirelessly Inside a Plant

100 Meter Indoor/ Upto 1 KM Outdoor (LOS)

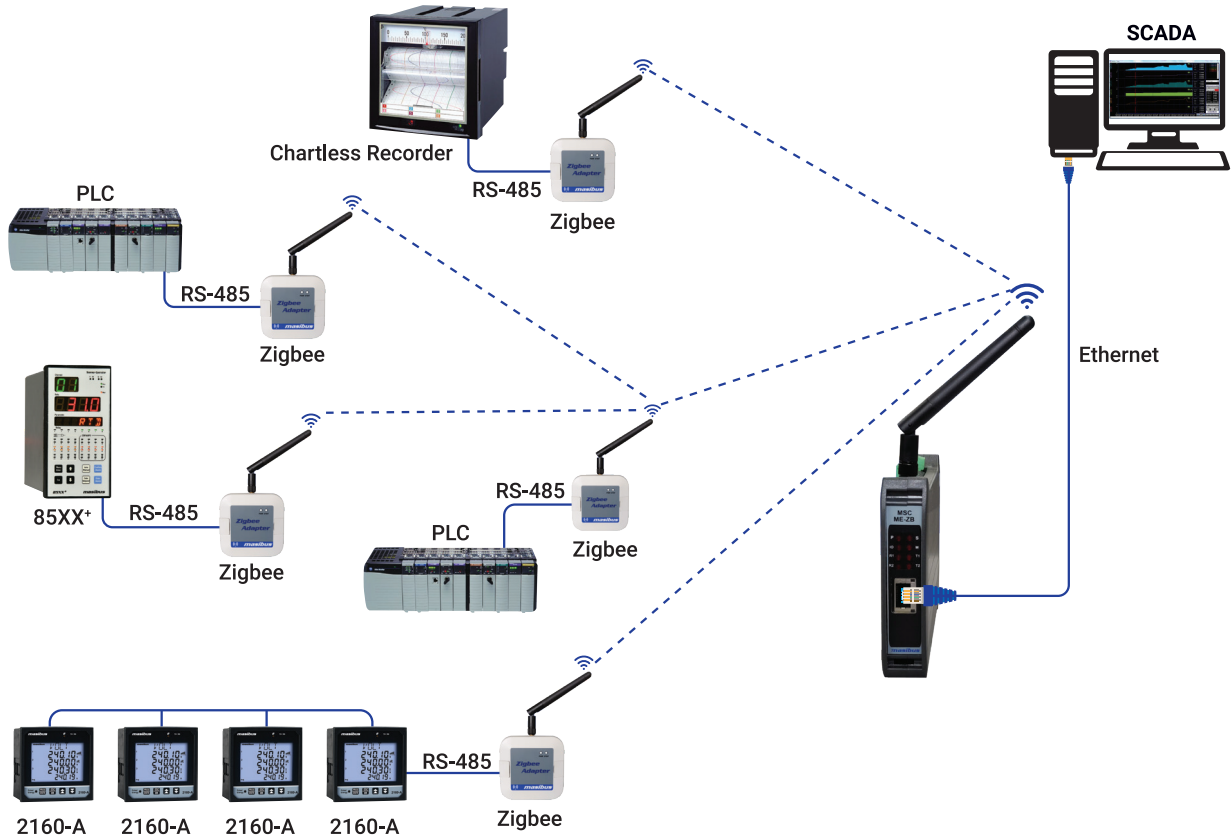

Connecting Devices Wirelessly for EMS Solution

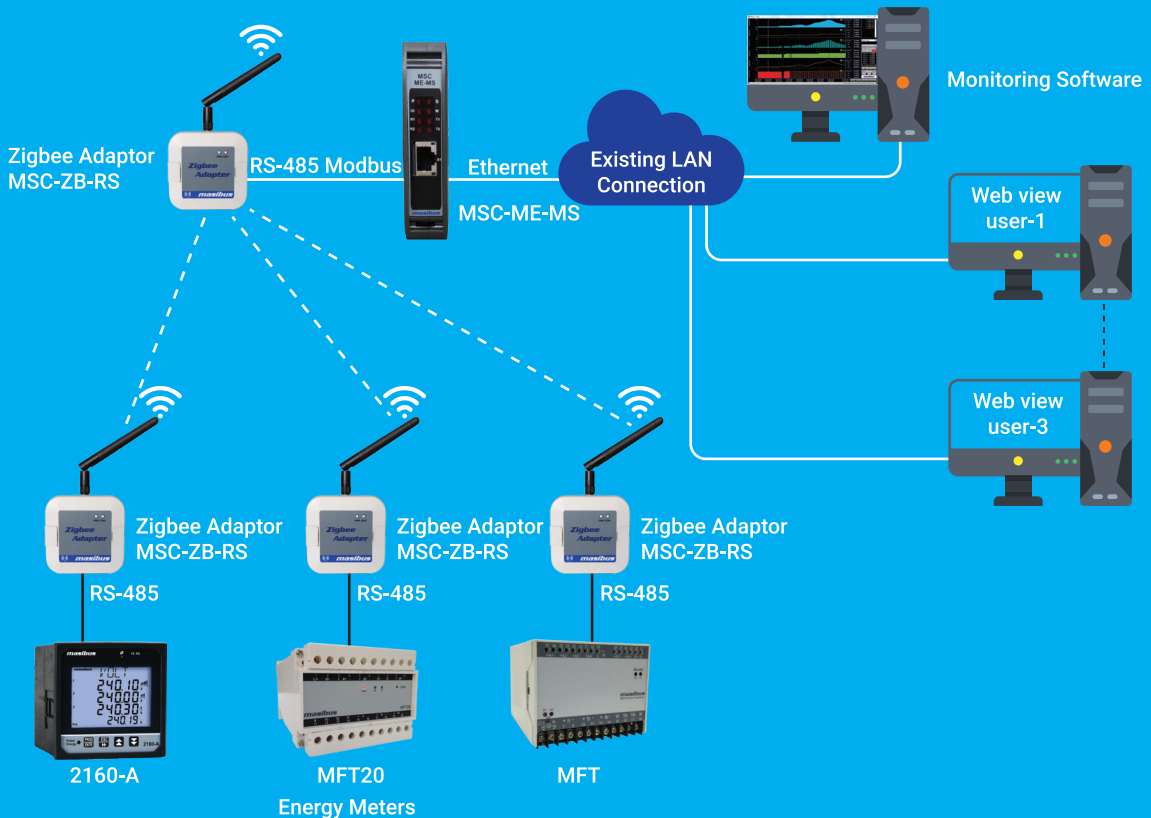

HT16u- Humidity Temperature Smart Logger



Features

- USB based HT16u with internal or external RH/T sensor with SS filter
- Temperature measurement -20 to 60 °C / -3.8 to 140 °F
- Humidity measurement 0 to 100 %
- Best in class accuracy @ 25°C +/-0.2°C temperature & +/- 2% RH
- Ultra low - battery power consumption with long life - CR2450 coin cell battery (1 Year @15min logging)
- Display battery status
- Logging start/stop - manual or pre-programmed (Auto) with pause facility
- SMART-HT free version - 3 devices in single report - Excel/PDF (Alarms & periodic data)
- SMART-HT license version - 10 Devices in single report/password protection in reports/21-CFR compliance with audit trails



HT16u

Warehouse Layout - Room Temperature Mapping



SMART HT Software

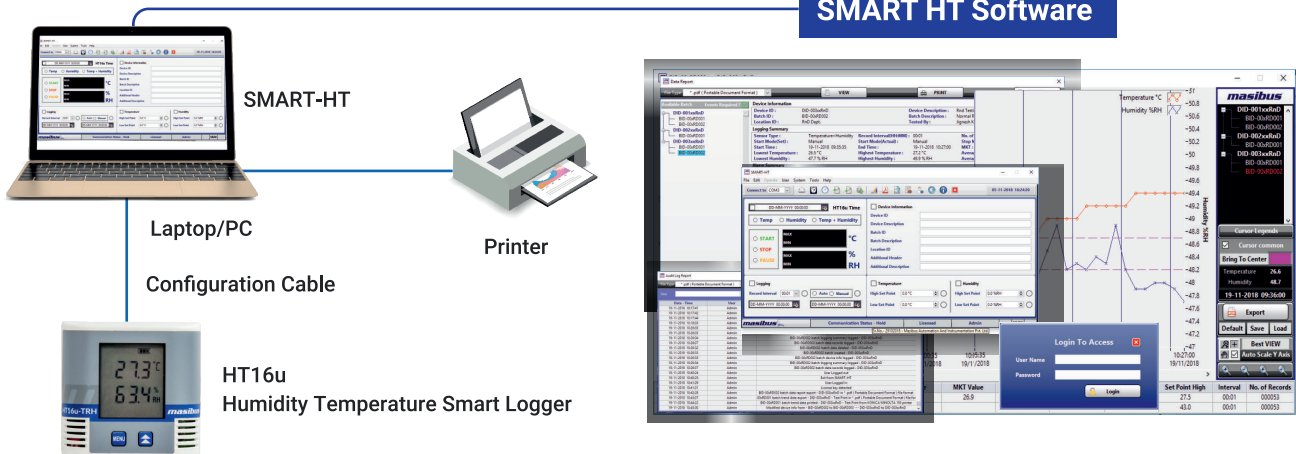

Pharma Industries

Clean Rooms & Warehouses

Food Industries

Cold Storages

Calibration Service Industries

HT16Ew - Wireless Humidity and Temperature Transmitter



Features

- Temperature & Humidity Measurements -20 to 60° T/ 0-100% RH
- Deep sleep wakeup transmit on 2.4 Ghz ZigBee Wireless
- Zero data loss from device to SCADA with data backfilling
- 12 HT16Ew can connect to one wireless receiver
- HT16Ew with rechargeable battery - 1 year @ 15 min log
- RTC display and synchronization with SCADA
- IP65 Enclosure for protection against dust and water
- Wireless receiver can connect to SCADA on DNP3 Ethernet



HT16Ew



RH/T External Sensor Probe

Environmental Monitoring / Warehouse Monitoring

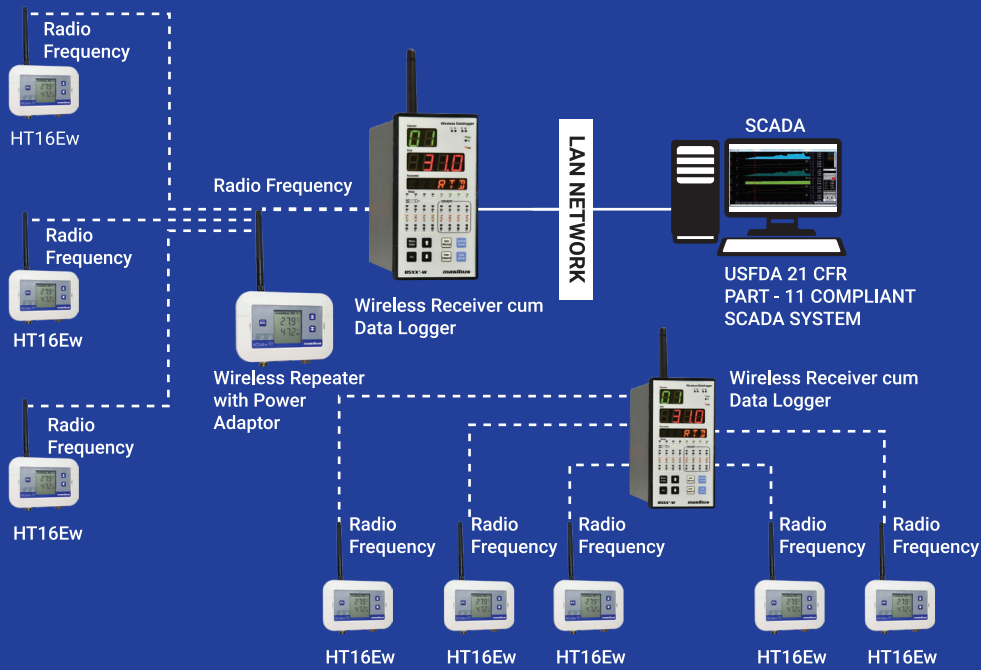

Environmental Monitoring / Clean Room Monitoring

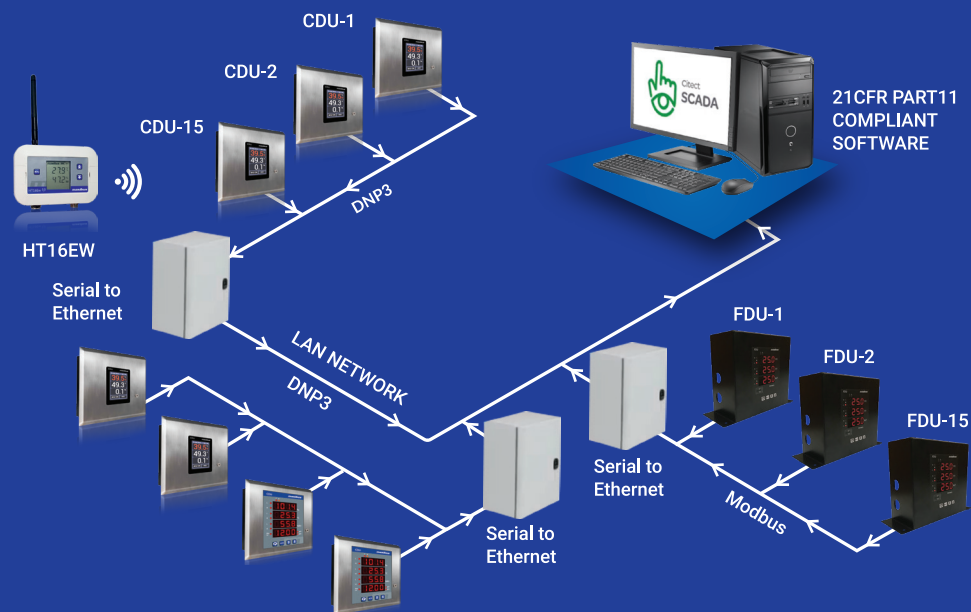

Protocol and Media Converters

Protocol Converters



MSC-ME-MS
(Modbus Serial to Modbus TCP/IP Data Concentrator/Gateway)

Features

- It converts Modbus Serial to Modbus TCP/IP
- Supports max. upto 64 Modbus RTU slave devices on RS-485
- No. of RS-485 ports (Modbus RTU Master): 2 (Only one active at a time)
- Modbus TCP/IP (ModNet) - 10/100Mbps- auto-detecting
- No. of client supports on Modbus TCP/IP (ModNet) - Up to 15
- Supports upto 192 Modbus commands
- 2048 Read/1024 write registers on Modbus

Features

- Supports max. upto 247 Modbus RTU slave IDs.
- No. of RS-485 ports (Modbus RTU master): 1 No.
- Modbus TCP/IP (ModNet) - 10/100Mbps- Auto detecting
- No. of client supports on Modbus TCP/IP (ModNet) - Up to 4 No.
- Not required any Modbus query Mapping/Configuration



MSC-RE-RS
(Modbus Serial to Modbus TCP/IP Protocol Converter)

Media Converters

Features

- RS-485 half duplex communication
- Communication speed (Baud rate) 1200 - 115200 bps
- Auto baud rate detection
- Signal boost up to 1200m (Depends upon baud rate)
- Maximum 31 RS-485 nodes per repeater
- 120Ω termination resistor selection
- Isolation 1500VAC RMS



MSC-RS-RS
(Isolated RS-485 to RS-485 Repeater)



- Convert the signals to RS-232
- Port: 9 PIN DB male connector
- Output - RS-232 full handshaking



mUSB232
(USB to RS-232 Converter)



mUSB485
(USB to RS-485 Converter)

- Convert the signals to RS-485 level
- Outputs: D + / D -
- Maximum 32 nodes
- 120Ω termination resistor selection

MSC-ME-MS as Modbus Gateway OR MSC-RE-RS as Modbus Protocol Converter

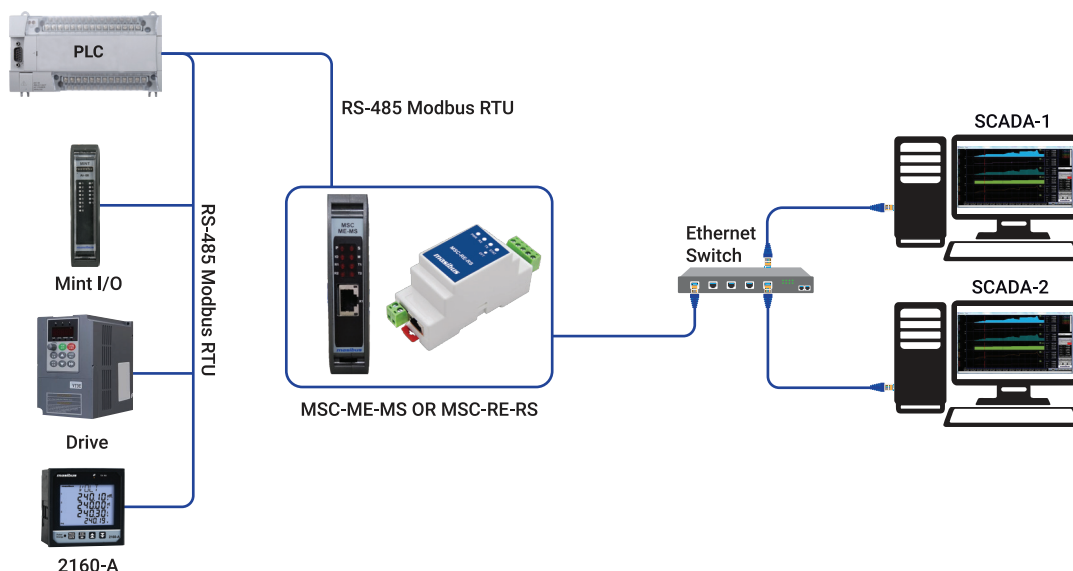

String Box Monitor (With Wired & Wireless)



String Box Monitor with Wireless ZigBee

Features

- 8/12/16/20 Channels String Inputs
- Built-in Shunt based DC Current Monitoring
- Measurement on the negative side string inputs
- Compatible with system voltage levels of up to 1500 VDC
- 02 RTD Sensor inputs for Temperature Monitoring
- 02 Digital inputs for DC disconnect and power SPD status
- -10°C to 70°C Operating temperature
- Input power supply: 18-36 VDC or 5 VDC
- 01 No. of RS-485 (2-wired) communication port
- On-board Wireless ZigBee communication module
- Modbus-RTU communication port
- Wireless ZigBee communication protocol
- Effortless communication with any SCADA system



SBM-S-1225 (Wireless)

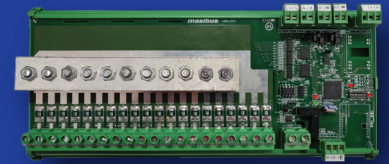

SBM-S-1225 (Wired)

String Box Monitor - Connection/Configuration

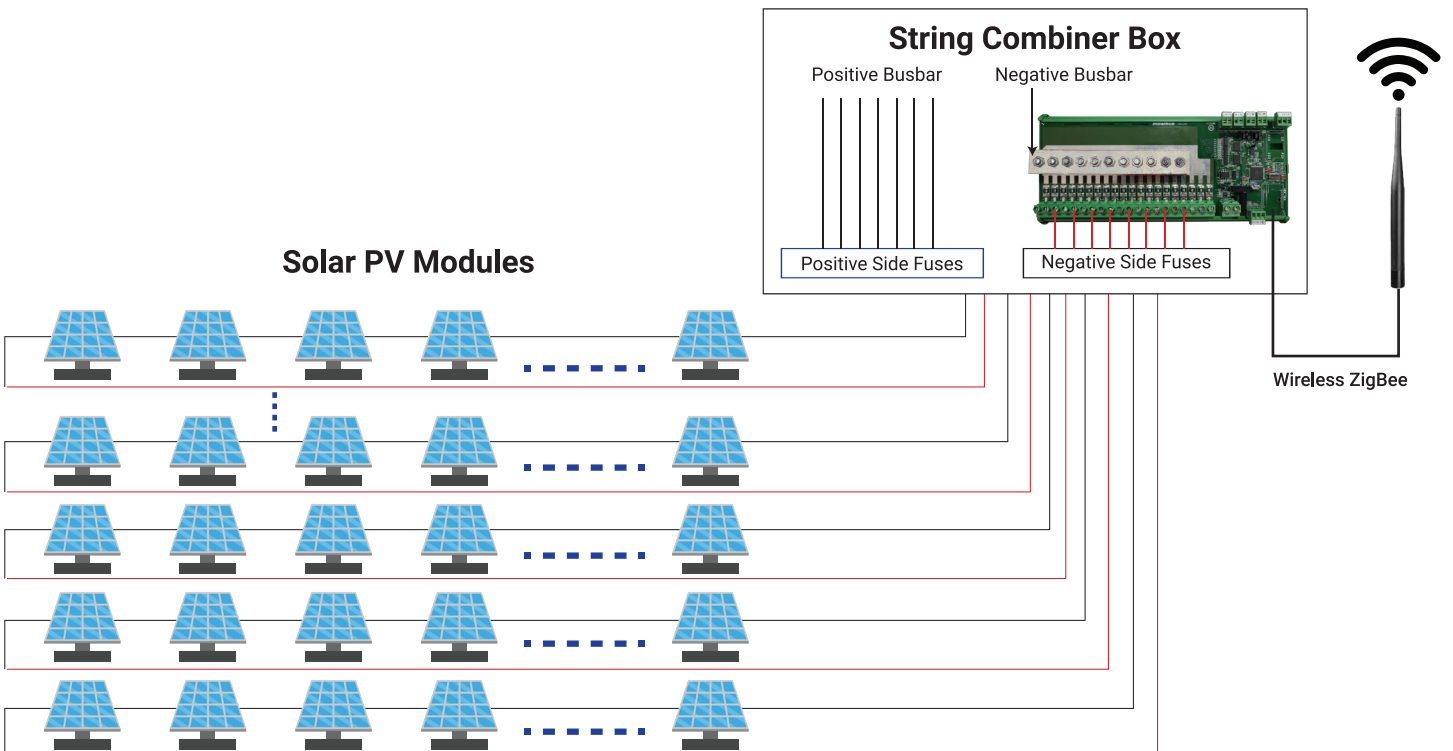

Application Examples

Layout –String Combiner Box to Control Room Communication

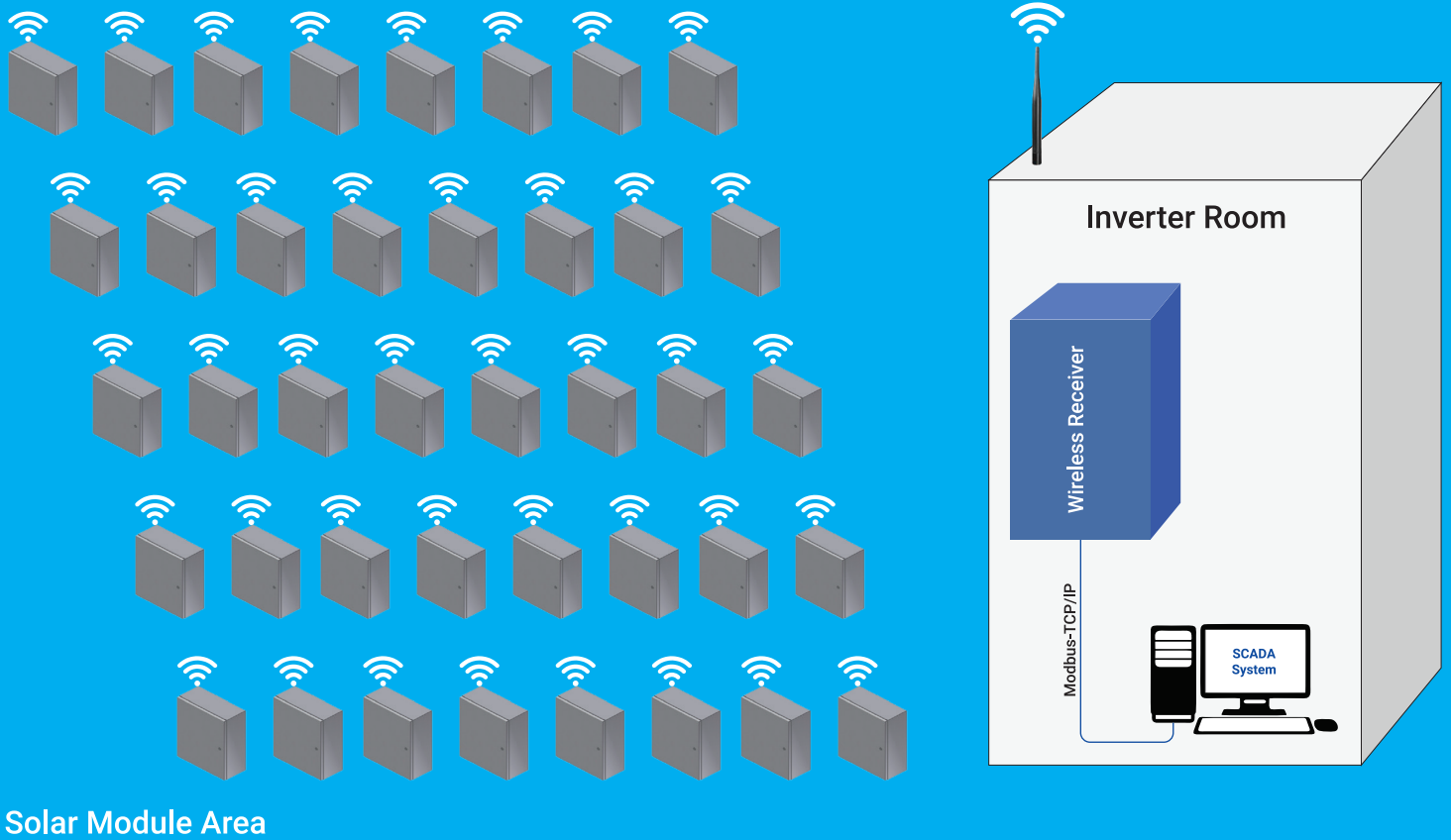

1

44 nos. Of String Combiner Boxes in 5MW Block

2

Wireless Communication From SCB to Inverter Rooms

3

String Data Available over Modbus TCP/IP @ Receiver

4

Distance - 500+ Meters

5

Zigbee Mesh Network

MSG-21 - IIoT Gateway Solution for any Modbus Slave Devices



Features

- 4G cellular or Ethernet (WAN) connectivity for MQTT broker
- Web server-based configuration for MQTT, Ethernet, Modbus RTU and Modbus TCP/IP
- Configurable MQTT (JSON) frame format
- Modbus TCP/IP Server Connectivity for HMI/PLC/SCADA
- Modbus TCP/IP client to read Modbus servers on ethernet
- Modbus RTU master to read Modbus RTU slaves on RS-485
- On board 2 Digital Inputs & 2 Digital Outputs operate remotely via SMS & MQTT
- Read Registers - Modbus RTU 512 Nos. & Modbus TCP/IP 256 Nos.
- Device Connection - Modbus RTU 32 Nos. & Modbus TCP/IP 8 Nos.
- Built-in 16MB memory to support back filling of time stamped data to server in the event of network failure



MSG-21

IIoT System for Remote Field Data Monitoring

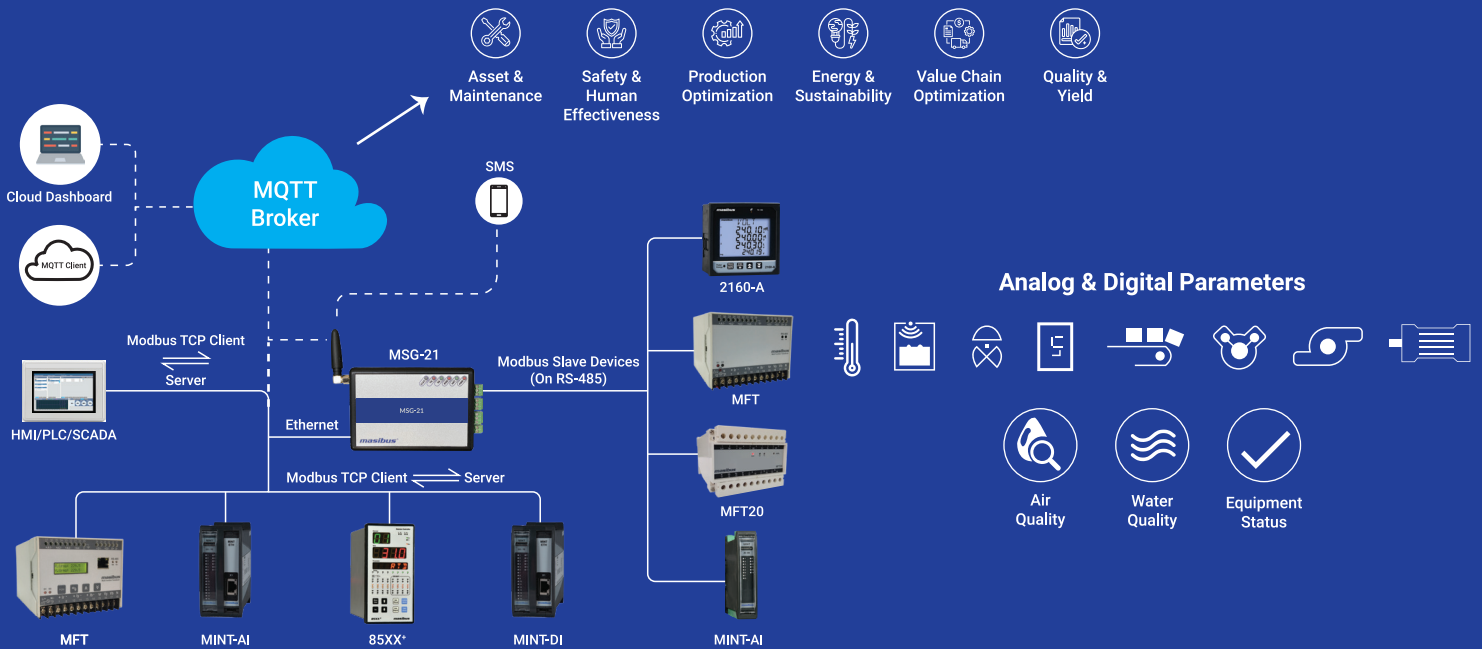

Remote Energy Monitoring Of Electrical Systems



PCC Panel / Switchgear Panel

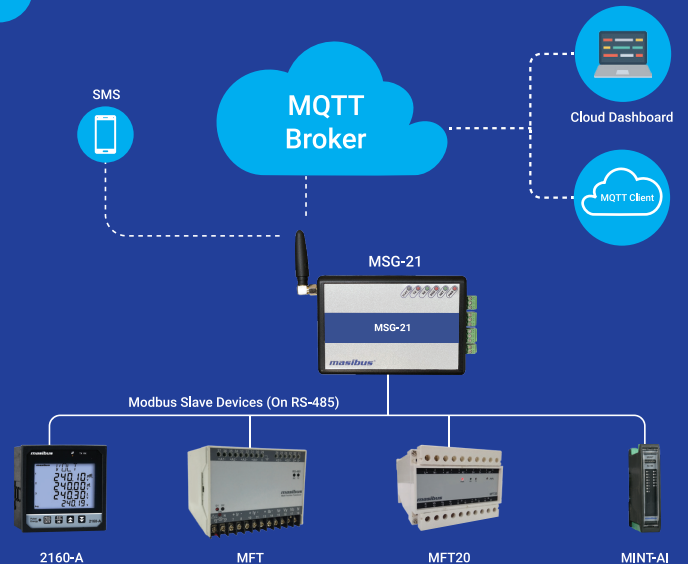

SMART 2.0 Software Tool for Reports, Alarms & Dashboards

Web Based | No Coding | 21-CFR Part-11 Compliance

Features

- **Data Connector:** Modbus RTU, Modbus TCP/IP, OPC DA/UA
- **Masibus Device Templates:** All masibus devices connectivity (85XX+, MINT IO's, Bargraph, Controllers, Energy Meters, etc.)
- **3rd Party Devices:** Any device with Modbus RS-485/Modbus TCP-IP support
- **Server Compatibility:** On-Premises / VM
- **Data Monitoring:** Real time and Historical data monitoring
- **Dashboards Screens:** KPI dashboards: Tabular, Pie/Donut, Gauge, Line Chart, Bar Graph
- **Reports:** Daily, Weekly, Monthly, Yearly Reports
- **Alarms:** Alarm generation based on L/L-L/H/H-H set points
- **Trends:** Live & Historical trends
- **Email:** E-mail reporting and automatic scheduling
- **21-CFR Part-11 User Management:** Optional
- **Licensed software** - 64/128/256/512/1024 tags supports

Key Specifications

- Suitable for On-premises Server/PC and Virtual Machine
- Supports up to 25 dashboards
- Supports up to 50-tags per dashboard
- Connectivity to all Modbus devices
- 21-CFR Part-11 user management
- 5 Web View Clients

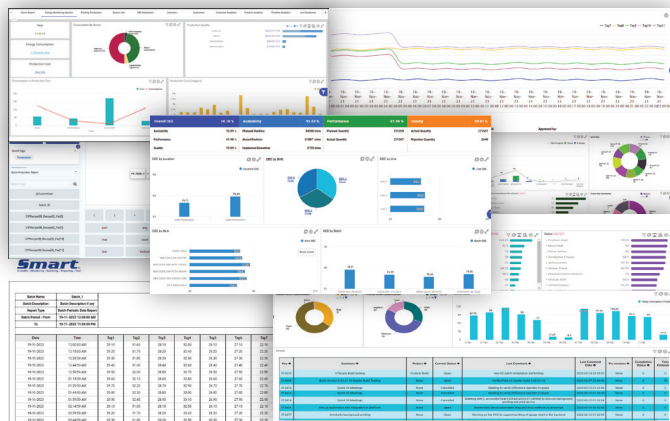

Data Monitoring & Logging

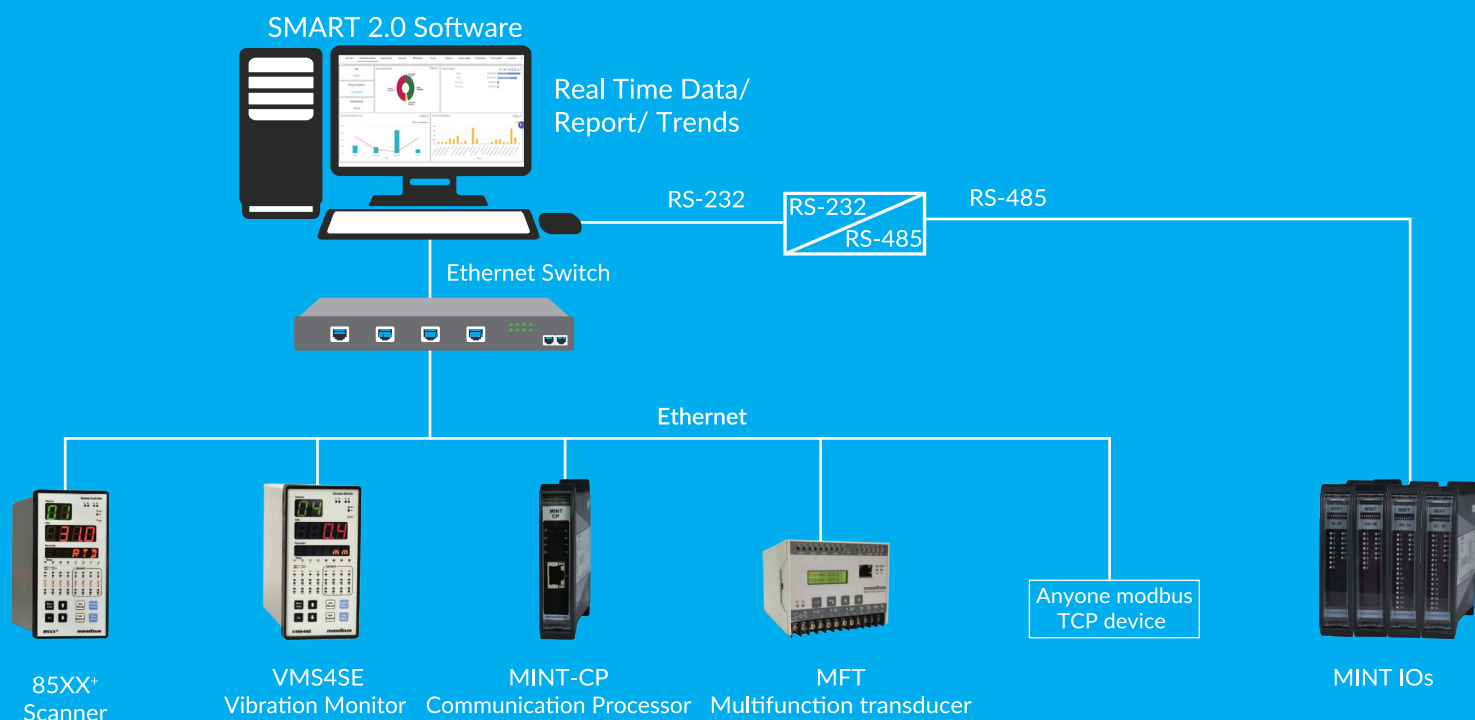

masibus

A Sonepar Company

Masibus Automation And Instrumentation Pvt. Ltd.

Gandhinagar

Address: B-30, G.I.D.C. Electronic Estate, Sector - 25, Gandhinagar - 382 024, Gujarat, India
E-mail: sales@masibus.com
Ph. No.: +91 9662042824

Goa

Address: C-6, Phase 1-A, Verna Industrial Estate, Verna, Salcette - 403722, Goa, India
E-mail: sales@masibus.com
Ph. No.: +91 9822135796

Sharjah

Address: A2-102, SAIF Zone, PO Box 120145 Sharjah, UAE
E-mail: sharjahall@masibus.com
Ph. No.: +971 65574650

Bengaluru

E-mail: sales@masibus.com
Ph. No.: +91 8732971943

Chennai

E-mail: sales@masibus.com
Ph. No.: +91 9725154195

Delhi

E-mail: sales@masibus.com
Ph. No.: +91 9909949742

Hyderabad

E-mail: sales@masibus.com
Ph. No.: +91 9909949062

Kolkata

E-mail: sales@masibus.com
Ph. No.: +91 9512003359

Mumbai

E-mail: sales@masibus.com
Ph. No.: +91 9689937234

Pune

E-mail: sales@masibus.com
Ph. No.: +91 9689937234

E-mail: sales@masibus.com
Website: www.masibus.com

Sales Service: TOLL FREE (India)
1-800-233-2273

Sonepar India Pvt. Ltd.

Gurgaon

Address: Plot No. 229/239, Village - Kherki Daula, Sector 76, Gurugram, Haryana, 122004, India

Kolkata

Address: 503, Block 4B, Ecospace Business Park, Newtown, Rajarhat, Kolkata, West Bengal, 700160, India

Chennai

Address: Plot No. 1, Gokul Garden, Melnallathur, Thiruvallur, Chennai, Tamil Nadu, 602002, India

Aurangabad

Address: FP-42, Five Star Industrial Area, Shendra MIDC, Aurangabad, Maharashtra, 431201, India

Panchkula

Address: Plot No. 263, Industrial Area, Phase-II, Panchkula, Haryana, 134113, India

Bhubaneswar

Address: Plot No. 443, 1st Floor, Saheed Nagar, Bhubaneswar, Odisha, 751007, India

E-mail: communications@soneparindia.com
Website: www.soneparindia.com