

**masibus**

A Sonepar Company

# Data Acquisition



DAQ Products



# Masibus DAQ Range of Products



AI-4 CH



AI-8 CH



AO-8 CH



DI-16 CH



DO-16 CH



MSC-ZB-RS



85XX+



8208

IO Cards for IIoT & PLC/DCS (MINT)

Wireless Products

Scanners & Data Loggers

Protocol Converters

IoT Gateway

Solar String Monitoring Module

Data Acquisition Software

DAQ  
Products



8204



8040



MSC-ME-MS



HT16u



MSC-PS-MS



MSC-ME-ZB



HT16Ew

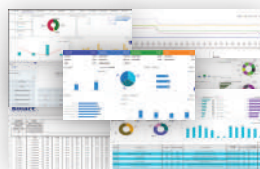

SMART 2.0 Software



MSG-21



SBM-S-1225

# All Masibus DAQ & other Products are IIoT Ready

## What is IoT?

The Internet of Things (IoT) describes the network of physical Objects/Things-that are embedded with sensors, software, and other technologies for the purpose of connecting and exchanging data with other devices and systems over the internet.

IoT Application can be classified broadly in Commercial & Industrial Domain as below

## Consumer IoT

Consumer IoT solutions are focused on individual users or families through the use of wearables ( e.g. Smart Watch ), smart home applications, and personal monitoring/assisting devices (e.g. Mobile Phone). A suitable example are voice smart assistants such as Amazon's Echo, Google's Home, and Apple's HomePod; in other words, products that make our lives easier by performing tasks or services for us, It's the network of connected devices and systems that can communicate and exchange data with each other.

## Industrial IoT (IIoT)

Unlike Consumer IoT, Industrial IoT targets existing automated industrial systems looking for dramatic improvements in productivity and efficiency. The most common IoT requirements comes from large scale factories or manufacturing plants, IoT also comes into picture for monitoring utilities and expensive assets. The IoT and IIoT ecosystem is growing and will keep growing more than exponentially in future . For this reason, we have to make sure that we choose the right products with suitable connectivity and functionality for our solutions in order to bring the sensor data to the supervisory level for suitable monitoring and decision making , the product should be having scalability feature to integrate more device in future with proper industrial handshaking & protocol.

## Automation Pyramid

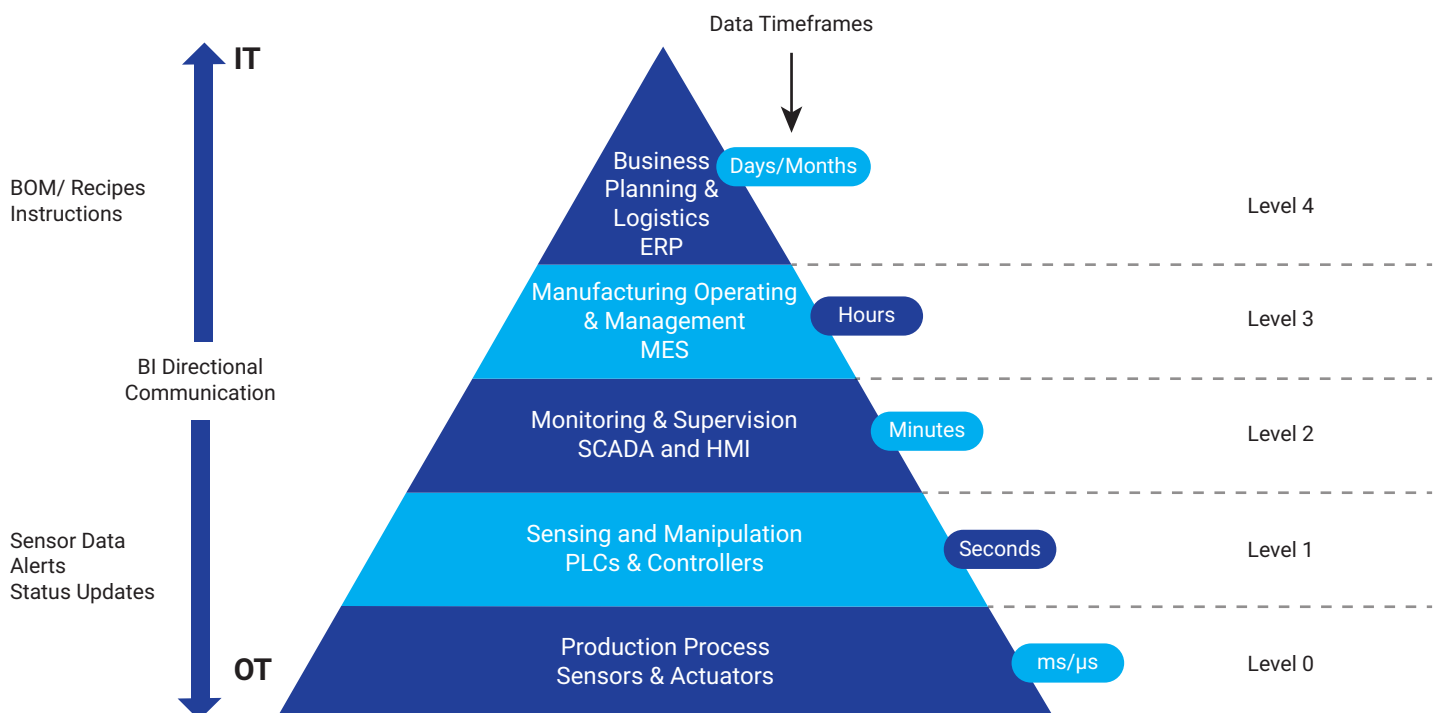

# Industrial Internet of Things (IIoT)

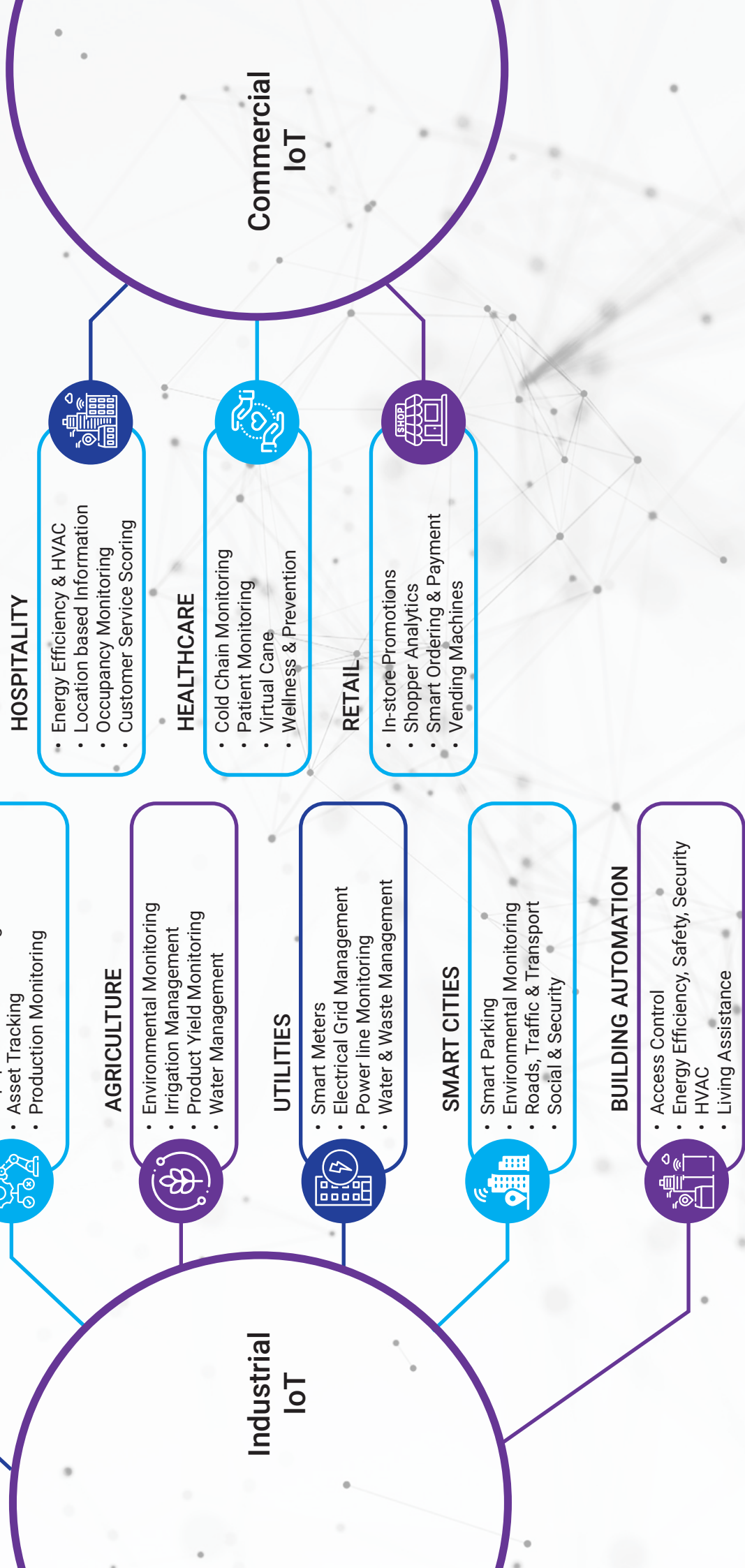

# I/O Cards from Masibus (MINT)



Analog Input



4 CH

Analog Input



8 CH

Analog Output



8 CH

Digital Input



16 CH

Digital Output



16 CH





MINT IO's comes with below different options

- 1 RS-485 Port
- 1 RS-485 + Ethernet Port
- 2 RS-485 Port

Protocol support - Modbus RTU  
Modbus TCP I/P

Can be connected with any make of PLC-CPU as I/O Card

Can be connected as Data Concentrator/Collector for IIoT Application

MINT IOs					
Model	4-AI	8-AI	8-AO	16-DI	16-DO
Channels	4	8	8	16	16
Type	Voltage/Current (Fix)	RTD/TC/ Voltage/Current (Universal)	Voltage/Current	24V DC input	Open collector 24VDC sink/ source 100mA per O/P
Isolation	Supply to field: 1500VAC RMS, Supply to RS-485: 1500VAC RMS, Field to logic: 1500VAC RMS				
Scan Time	50ms/ Ch.	RTD-100ms/Ch. Other-50ms/Ch.	All 8 Ch. in <500ms	500 µs	Configurable
Resolution/ Accuracy	16 bit ADC 0-1 %	16 bit ADC 0.1%	16 bit DAC 0.05%	1 KHz 32 Bit Counter	10ms Pulse O/P

## PLC with IOs on RS-485 - Modbus RTU

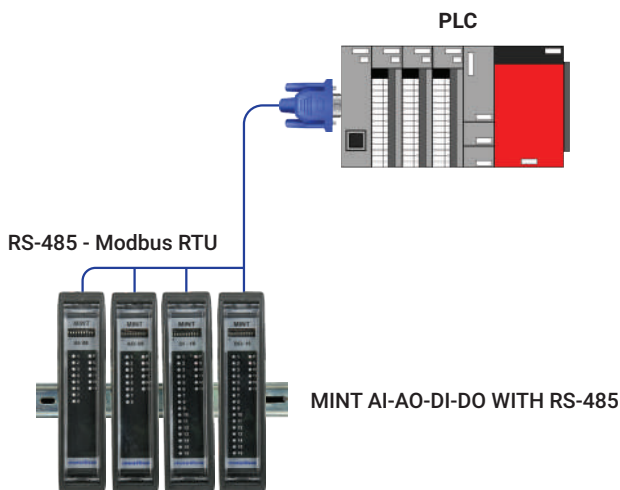

## Mint CP with I/O on Modbus TCP/IP to PLC & Mint IO's to HMI on RS-485-Modbus

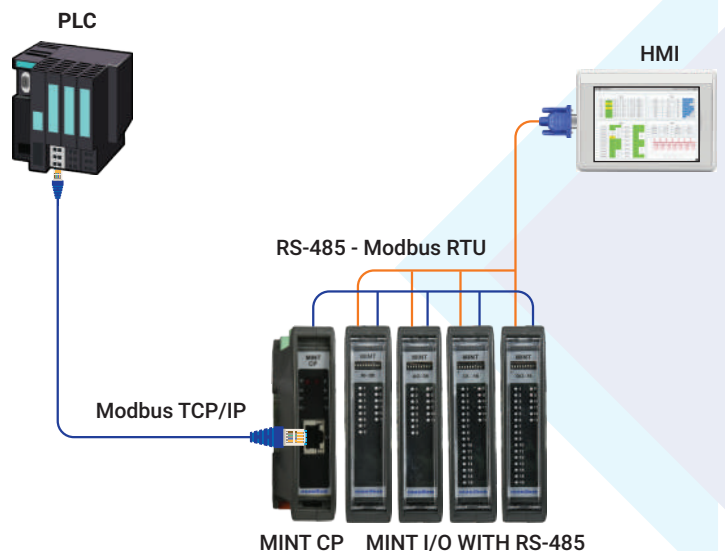

# Application Examples

## PLC/HMI as Multiple Clients Connect to MINT Ethernet IO on Modbus TCP/IP

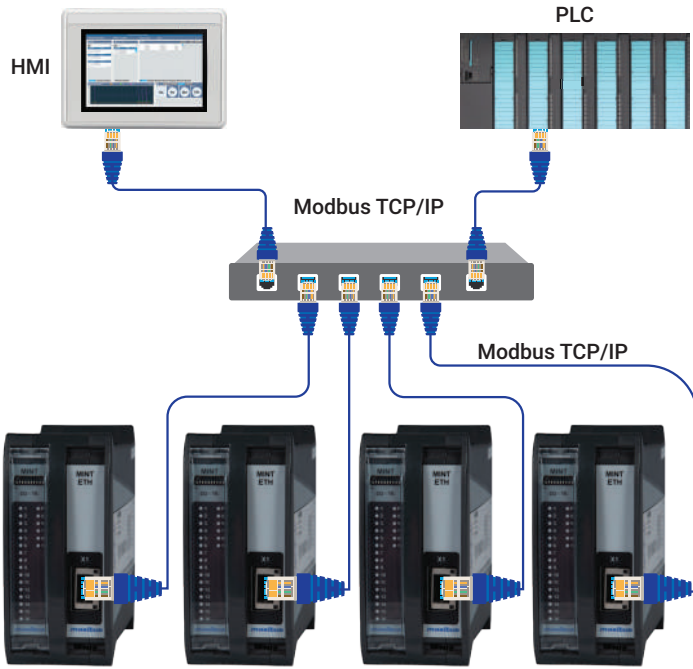

MINT ETHERNET I/O WITH MODBUS TCP/IP

## MINT IO's to HMI on RS-485-Modbus

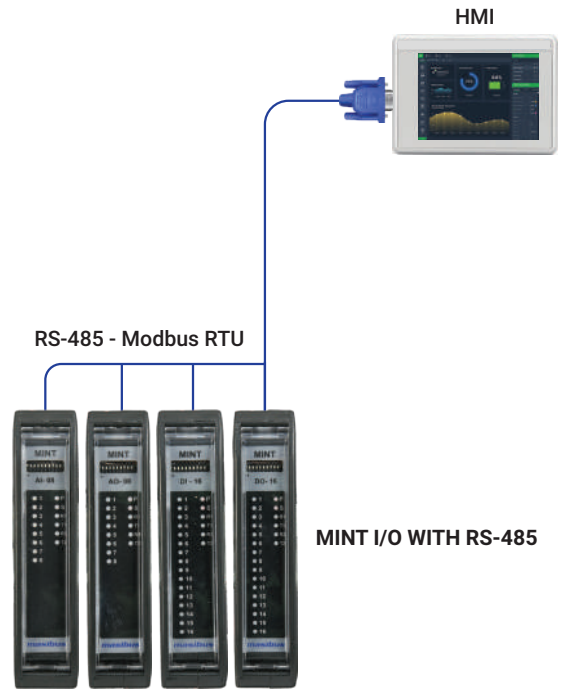

MINT I/O WITH RS-485

## PLC with IOs on RS-485 - Daisy Chain

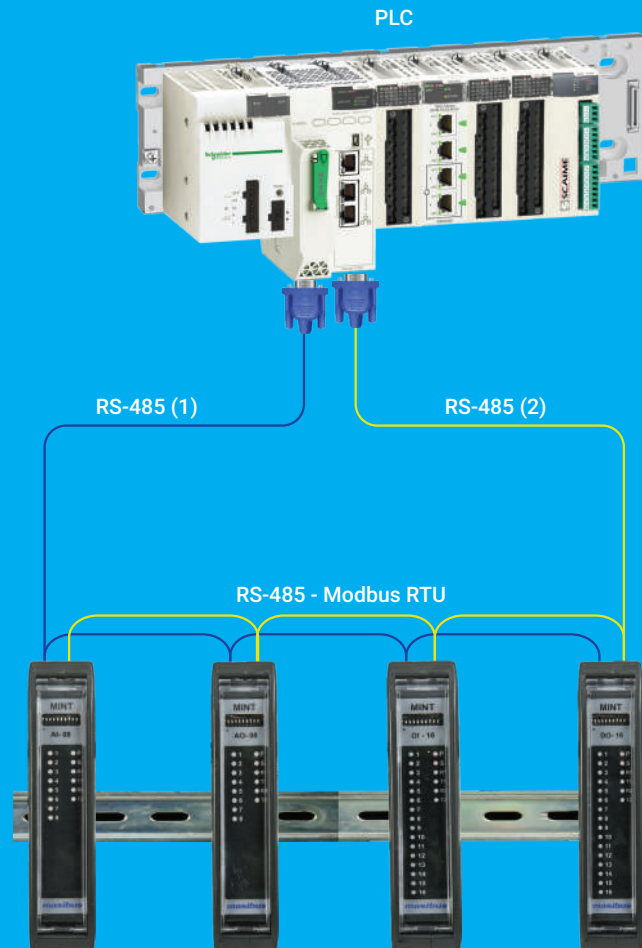

MINT AI-AO-DI-DO WITH RS-485



# Application Examples

## Communication Processor for MINT I/O



**MINT-CP**

Performance	
Maximum No. of Read Registers	1024
Maximum No. of Write Registers	1024
Maximum No. of Modbus Commands Supported	100
No. of Slave Devices Supported per Serial Port	No. of Modbus devices supports on serial port - 15
No. of Clients Supported on TCP/IP	Up to 15
Communication	
RS-485 Serial Port	2 Nos.
Protocol	Modbus-RTU slave
Ethernet Port	1 Nos.
Protocol	Modbus TCP/IP (Modnet)

## Configuring MINT I/O as Redundant I/O System

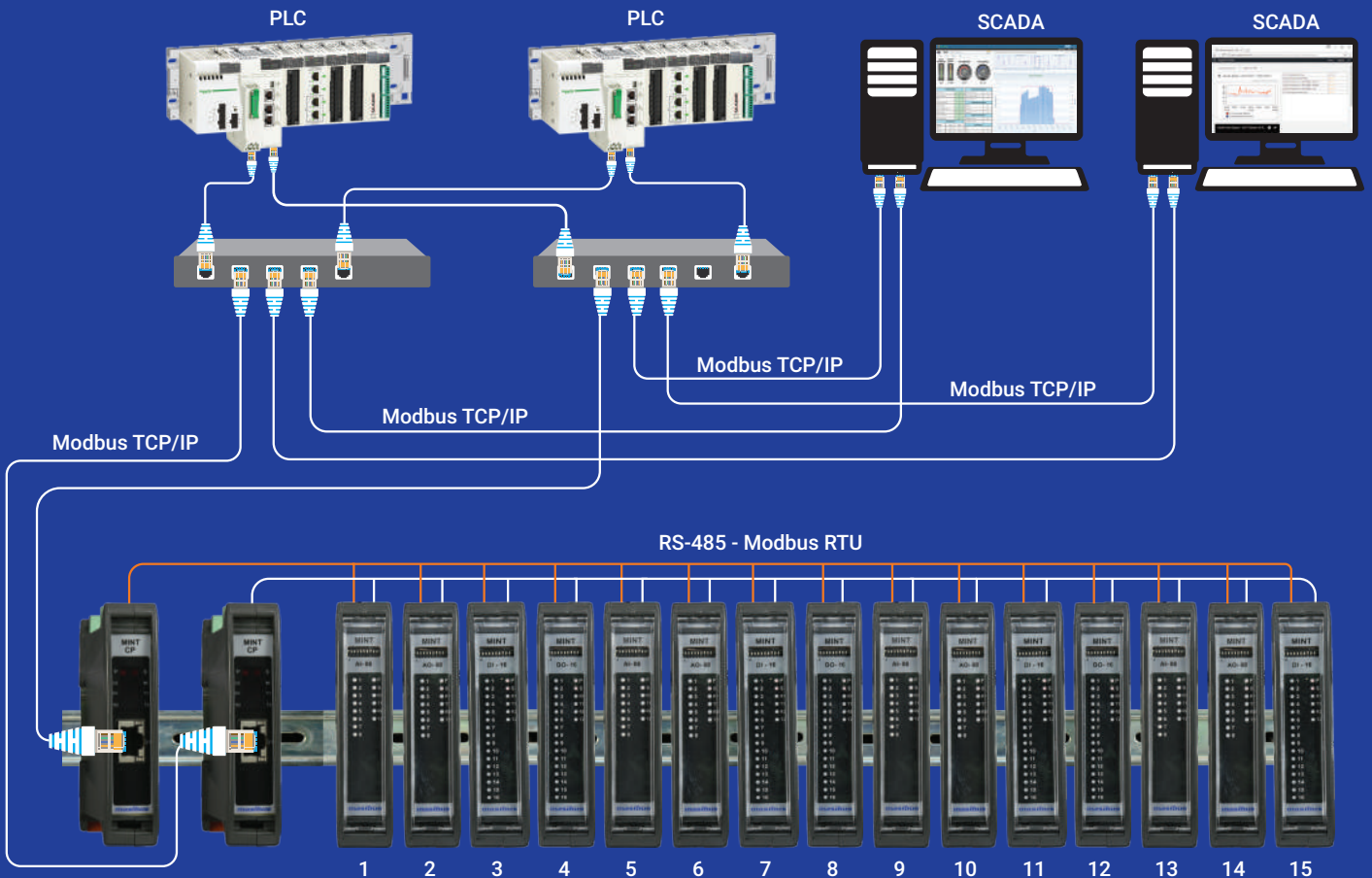

# Application Examples

## MINT-DI as 1 KHz High Speed Counter

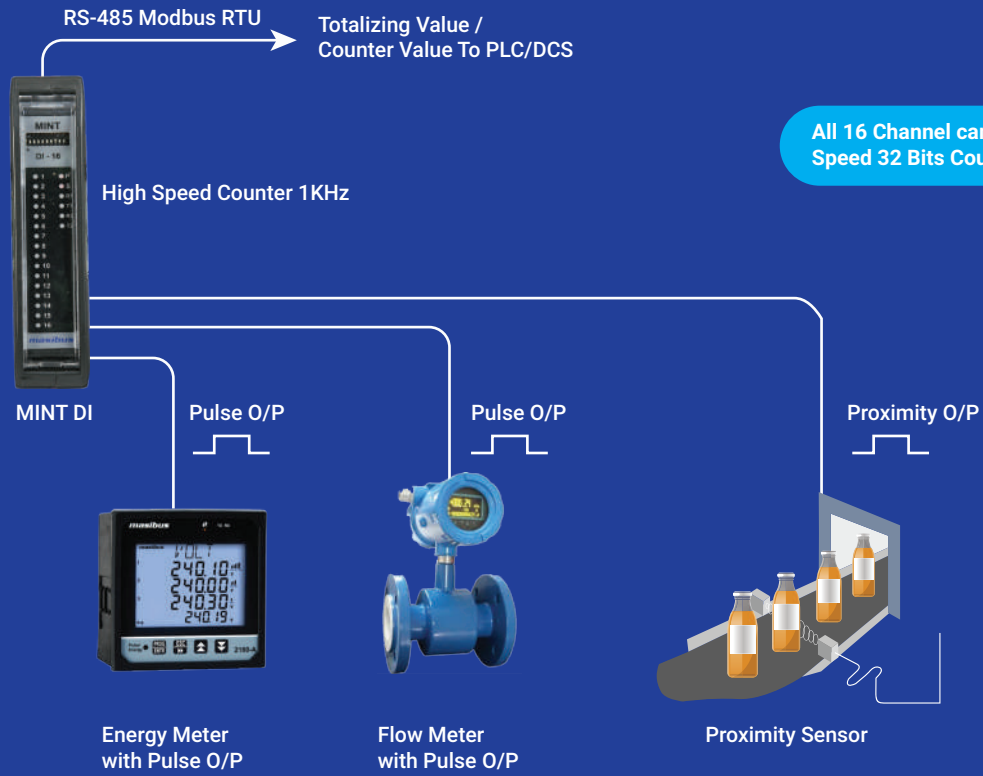

## Configuring a larger I/O System with MINT I/O

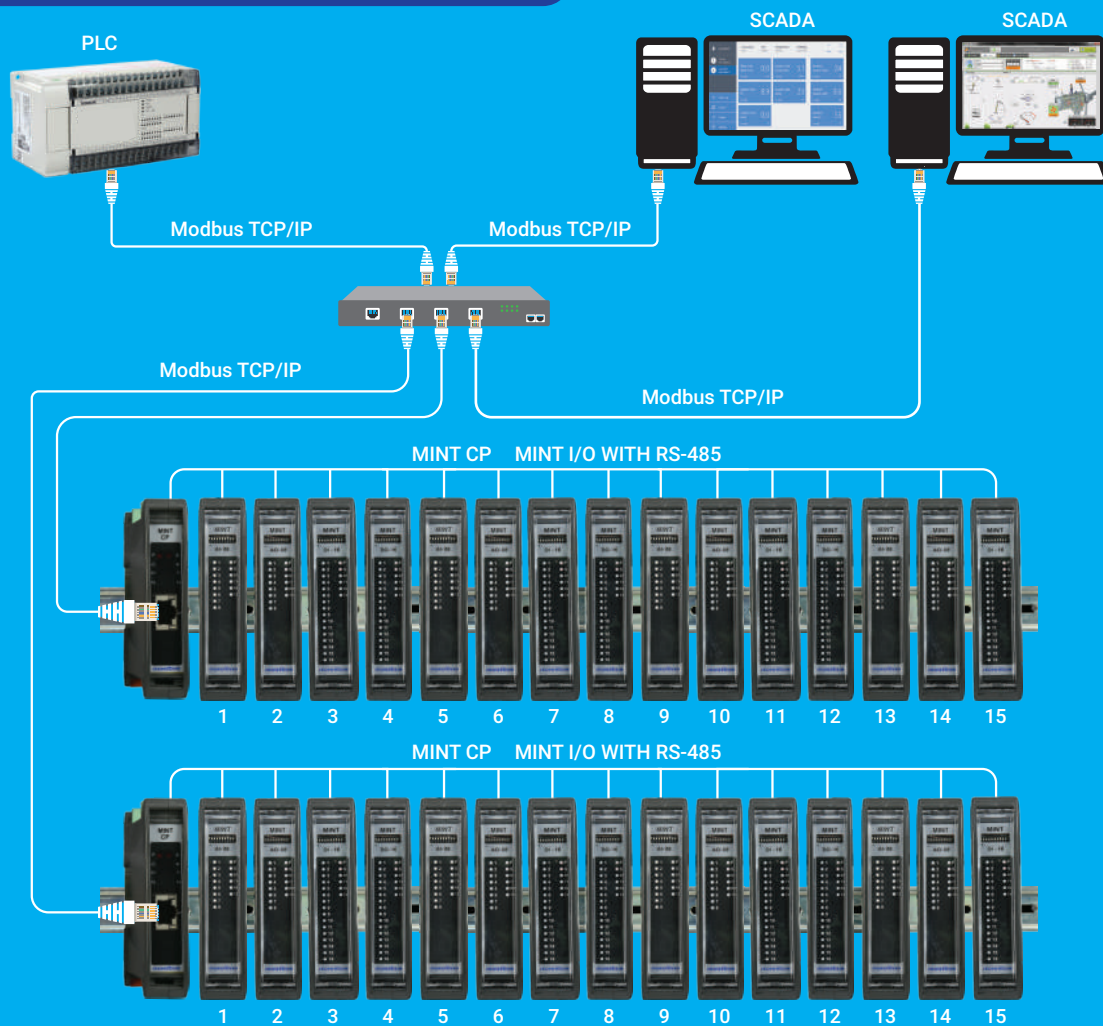



## Reproducing AI & DI Signal for a Long Distance Transmission Concept of I/O Pair for DI & AI Signal for PLC & DCS System

### I/O Pair for Analog Input

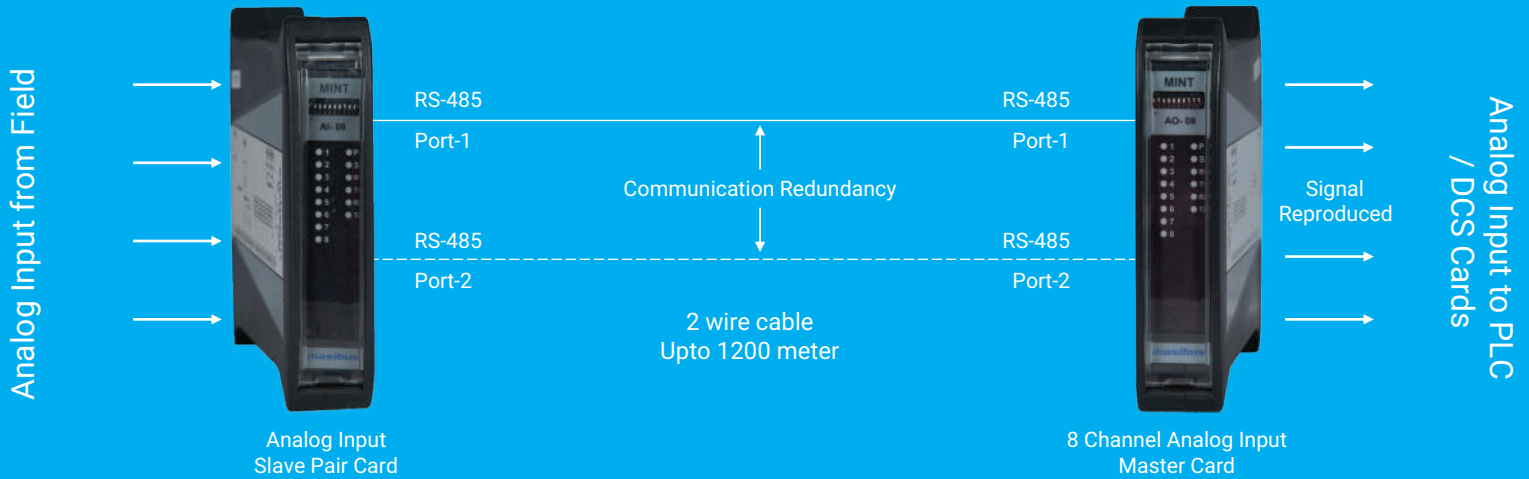

### I/O Pair for Digital Input

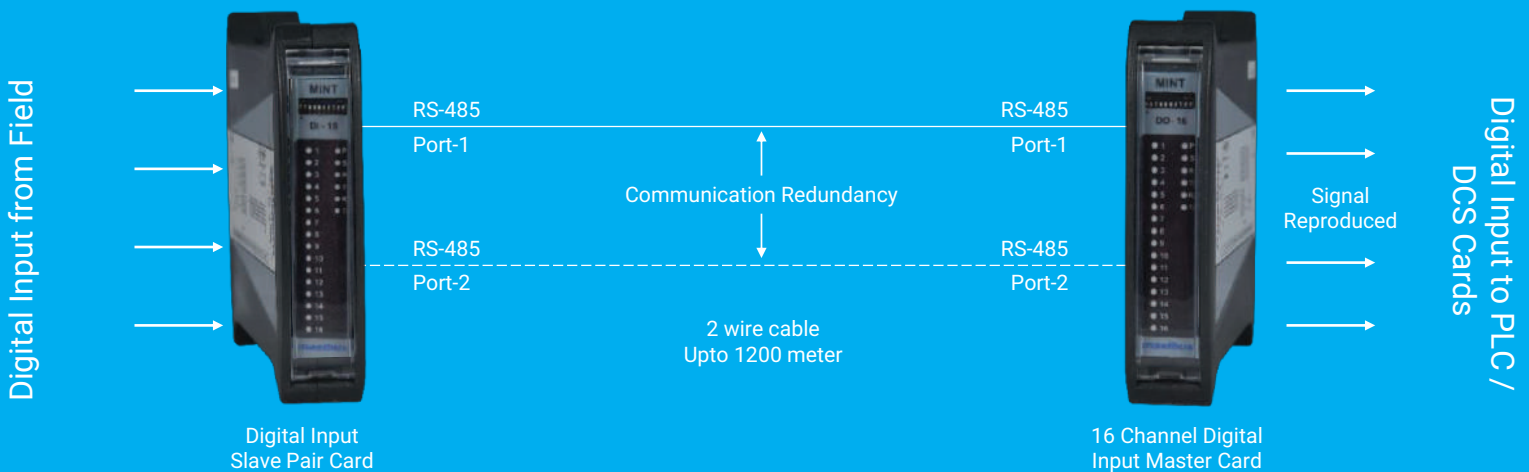

- 8 Channel Analog Input master-slave pair
- 16 Channel Digital Input master-slave pair
- Works with any PLC/DCS make
- Plug & play solution
- Reduces the cable cost for field signals
- Channel density can be increased or decreased if required
- Communication redundancy possible with 2 pair of dedicated RS-485 port
- No programming is required
- Master slave pair reproduces the signal from remote end to central PLC / DCS end upto 1200 meter a part



**8204**  
(4-Channel Scanner)



**8208**  
(8-Channel Scanner)



**85XX+**  
(8/16/24-Channel Scanner & Data Logger)



**8040**  
(128-Channel Data Logger)







**8208-IP**  
(8-Channel Weather Proof Scanner IP-65 Enclosure)



**8208-XP**  
(8-Channel Ex-Proof Scanner for Hazardous Areas)

# Scanner & Data Logger

Scanner & Data Logger							
Model		8204 4-Ch. Scanner	8208 8-Ch. Scanner	85XX+ 8/16/24-Ch. Scanner & Data Logger	8040 128-Ch. Data Logger	8208-IP 8-Ch. Weather Proof Scanner IP-65 Enclosure	8208-XP 8-Ch. Ex-Proof Scanner for Hazardous Areas
Input	AI	4	8	8/16/24	16 to 128	4/8	4/8
	DI	-	-	16	-	-	-
Output	RL	4	4	8/16	16	4	4
	OC	-	-	24	32	-	-
	AO	1	1	8	-	1	1
Serial Port RS-485		1	1	2	2	2	2
Ethernet (ModbusTCP)		-	-	1	1	-	-
Profibus DPV0		-	-	1	-	-	-
USB Pendrive Port		-	-	1	1	-	-
Input Scan Time		1 Sec.	1 Sec.	1 Sec.	3.2 Sec.	1 Sec.	1 Sec.
Internal Data Log Memory		-	-	32 MB	32 MB	-	-
Isolation		Power to Field 1500VAC Field to Communication 1500VAC Power to Communication 1500VAC			Channel to Channel 125VAC/300VDC Power to Field 1500VAC Field to Communication 1500VAC Power to Communication 1500VAC	Power to Field 1500VAC Field to Communication 1500VAC Power to Communication 1500VAC	
Enclosure		ABS 1/8 DIN mount	ABS 1/4 DIN mount	Steel Sheet Powder Coated	19' Sub-Rack	Steel Sheet Powder Coated IP65	Aluminium Alloy LM-6 Gas Groups IIA & IIB, IP65, Zone: 1, 2 Optional IIC
Connections		Screw Terminals	Screw Terminals	Prefab Cables & Field Interface Module (Option) 	Prefab Cables & Field Interface Module (Option) 	Cable Gland	Cable Gland

# Application Examples

## Motor Current, Temperature Monitoring & Control

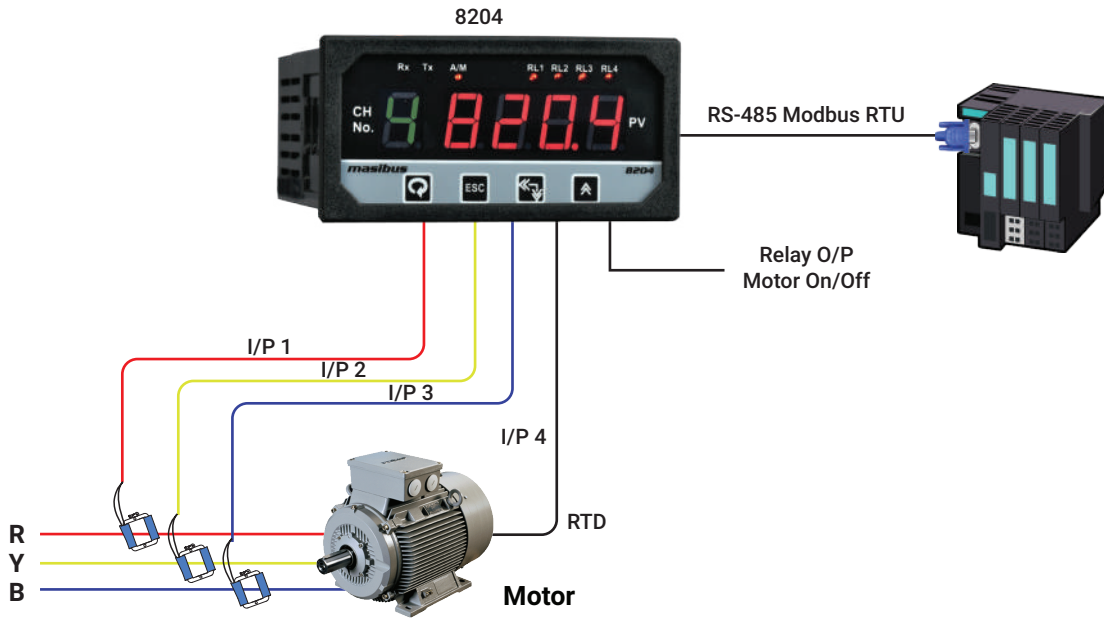

## Barrel Zones Temperature Monitoring & Heater Control for Plastic Extrusion Machines

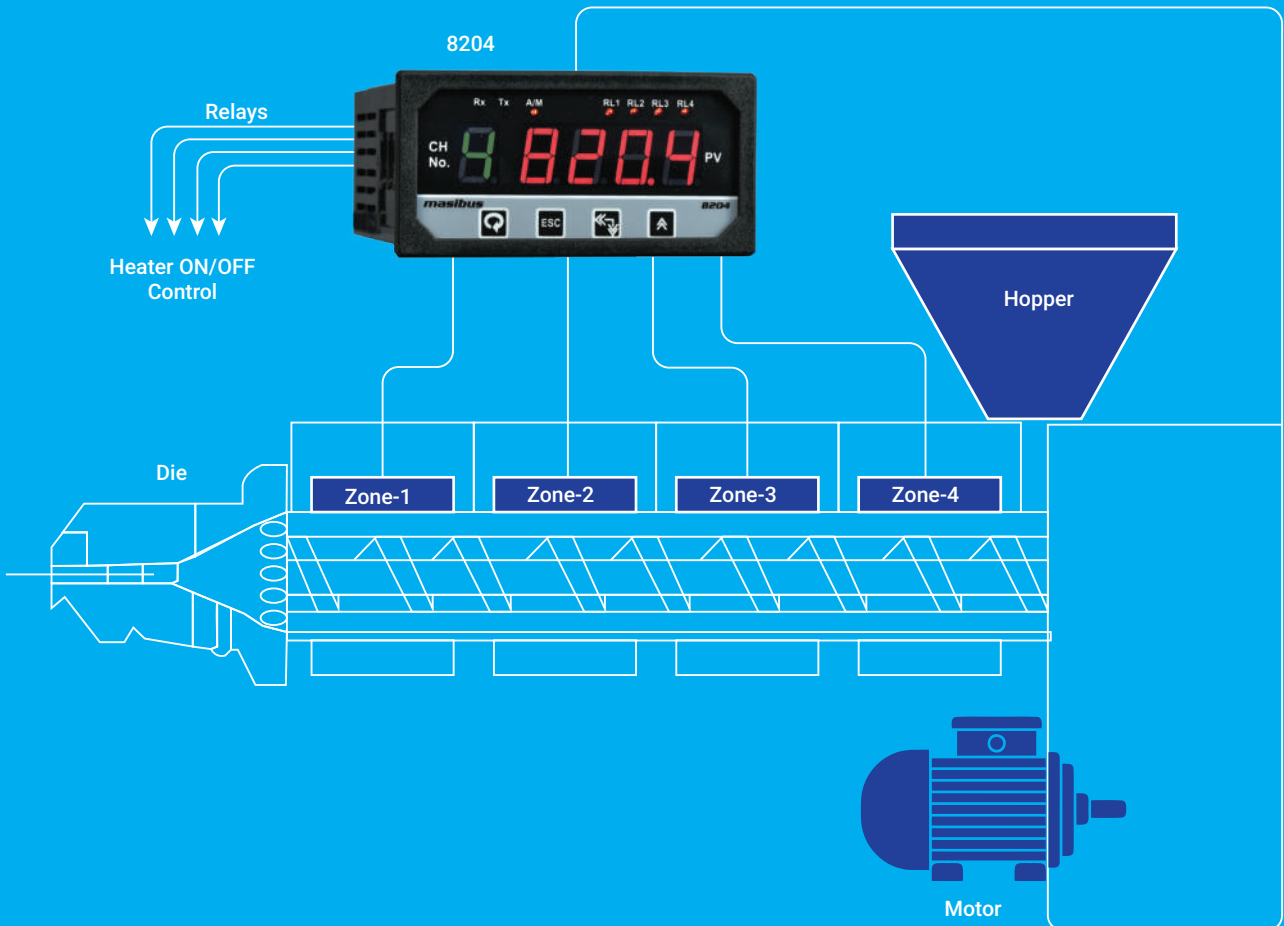



# Application Examples

## 8208-IP as Transformer Protection Relay

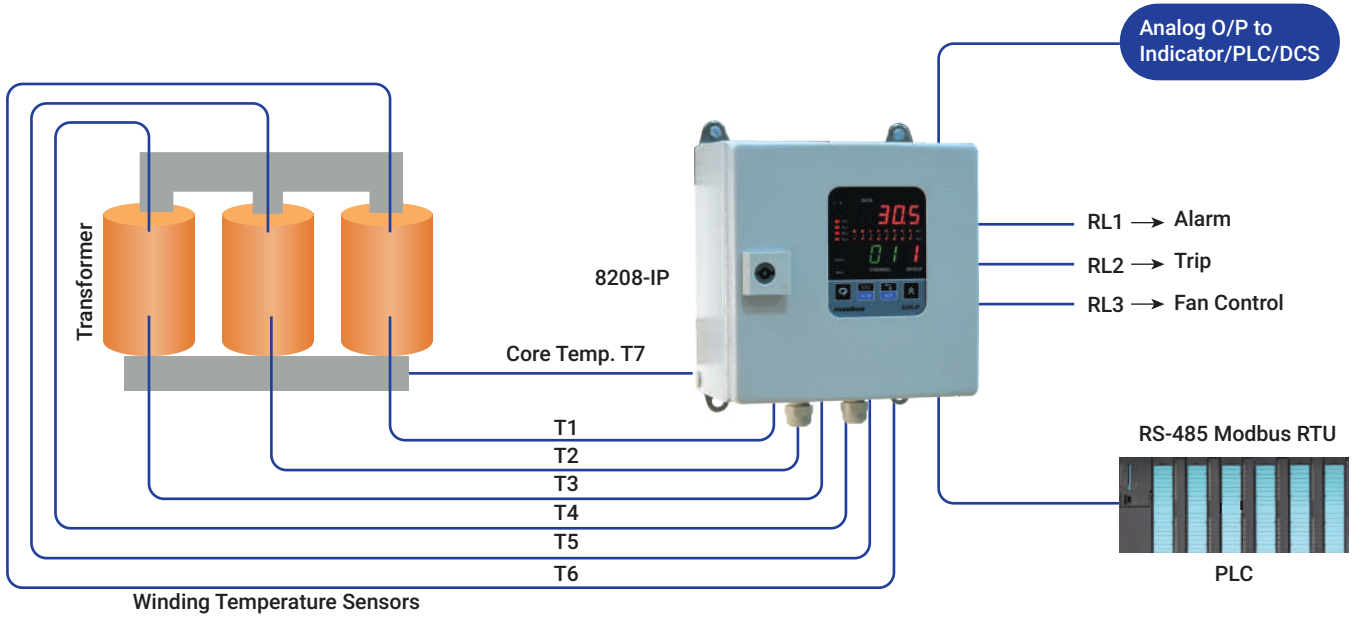

## Motor Temperature Measurement & Protection

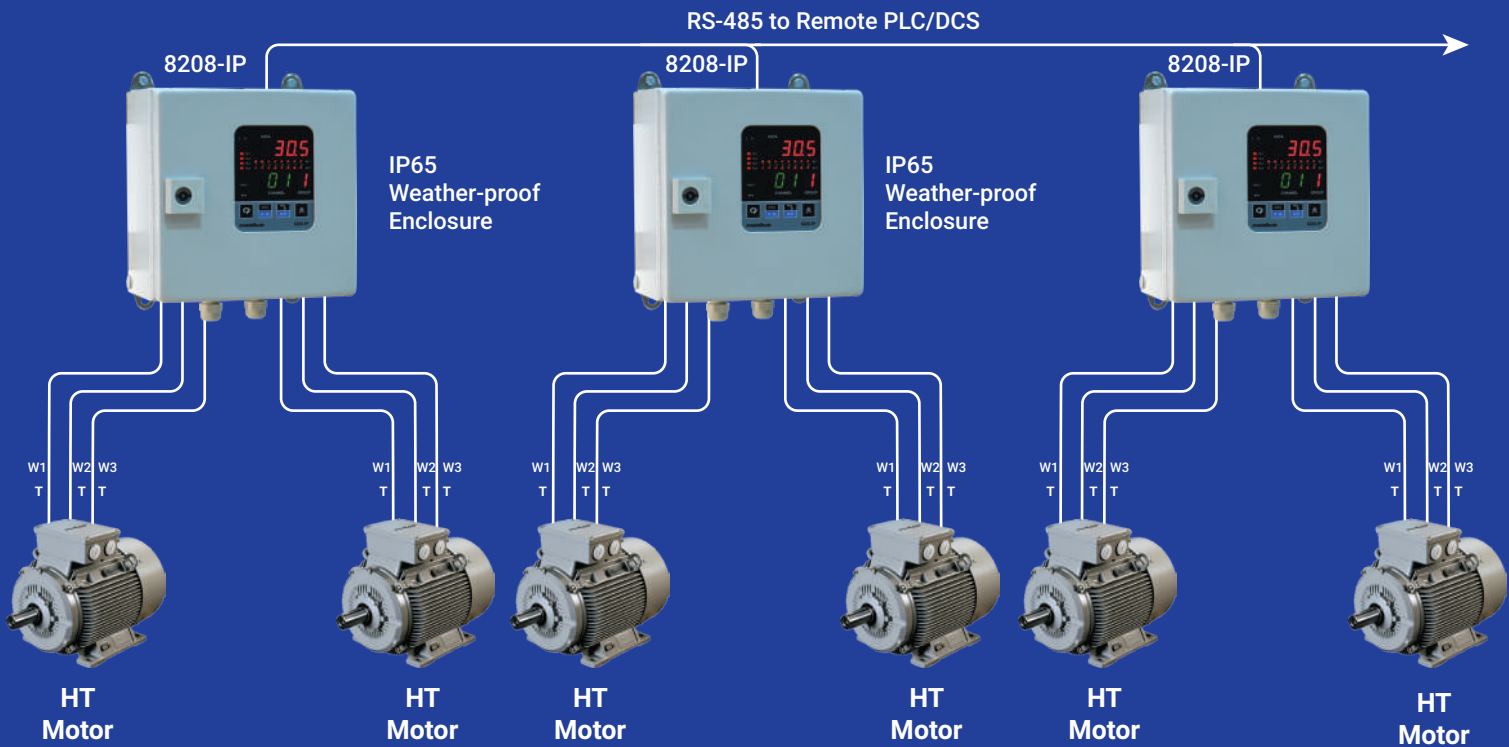

# Application Examples

## Motor Temperature Measurement and Protection

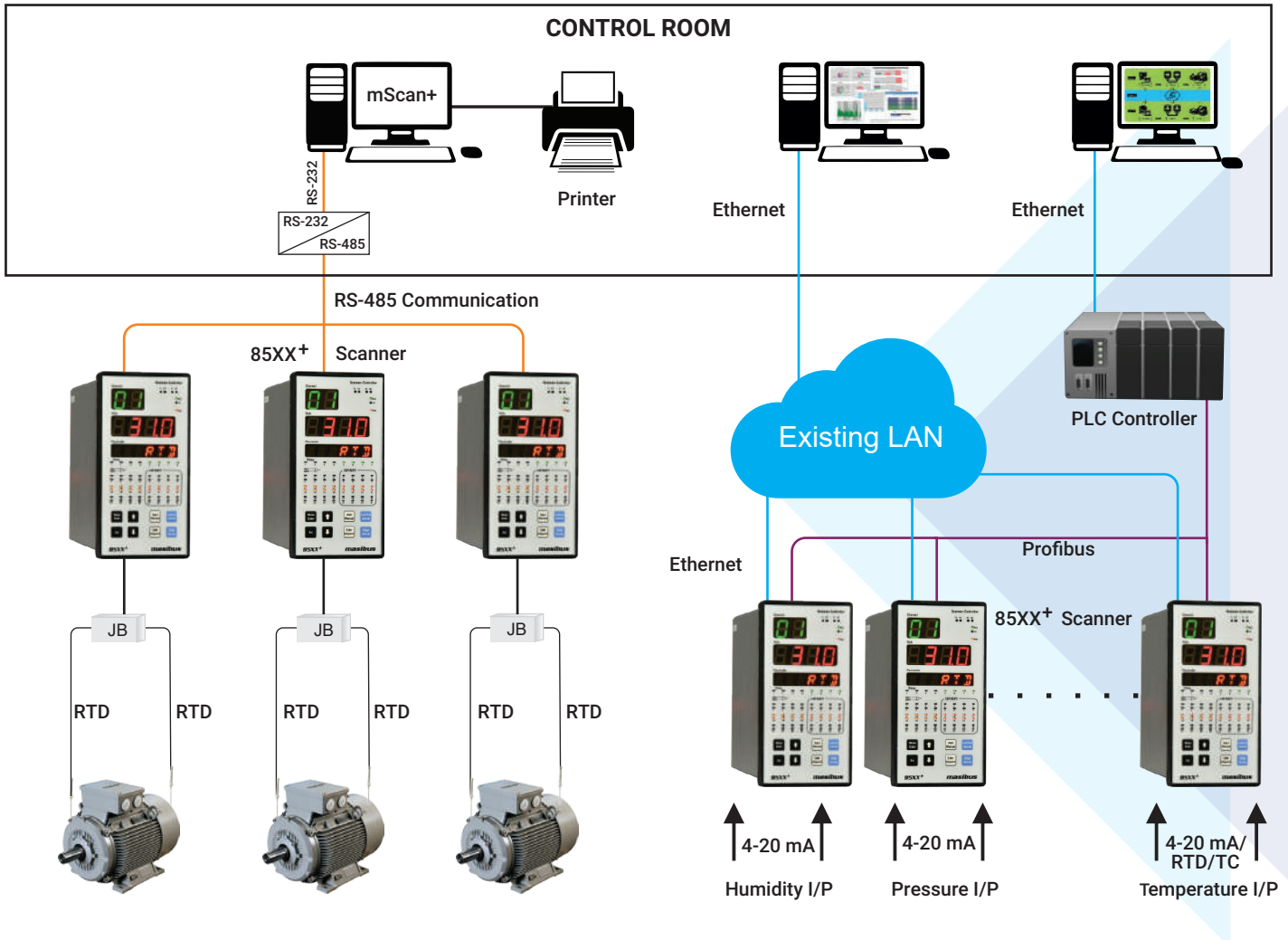

## 85XX+ as 24 Channel Analog I/O Module for any PLC/DCS

It can eliminate 3 RTD/ 3 Thermocouple  
& 16 Ch. DO PLC I/O Cards



# Busbar Junction Temperature Monitoring for Preventive and Predictive Maintenance of LT Distribution Panels

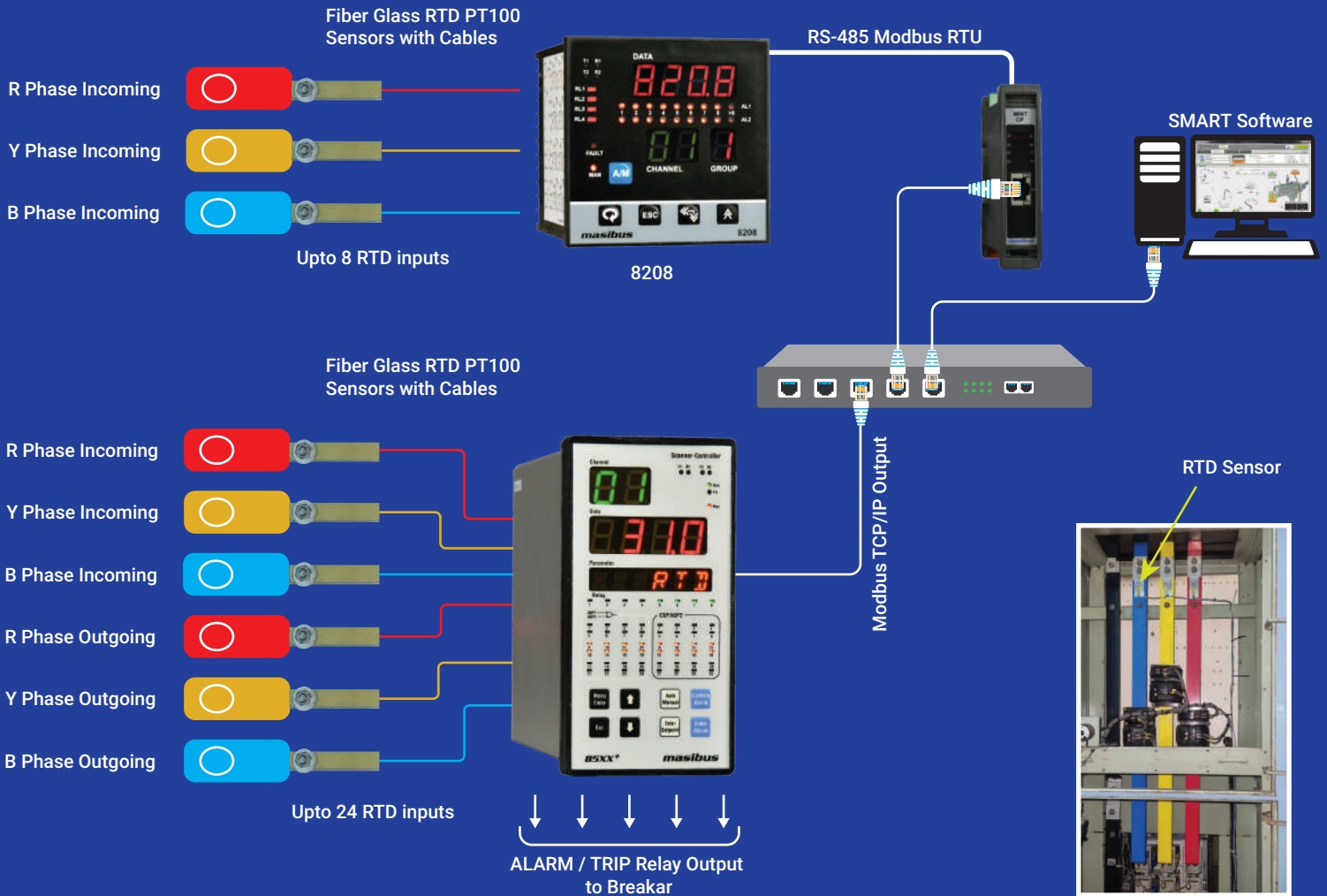

## Configuring 85XX+ for 16-Digital Inputs 8-Relay Outputs & 24-Analog Inputs

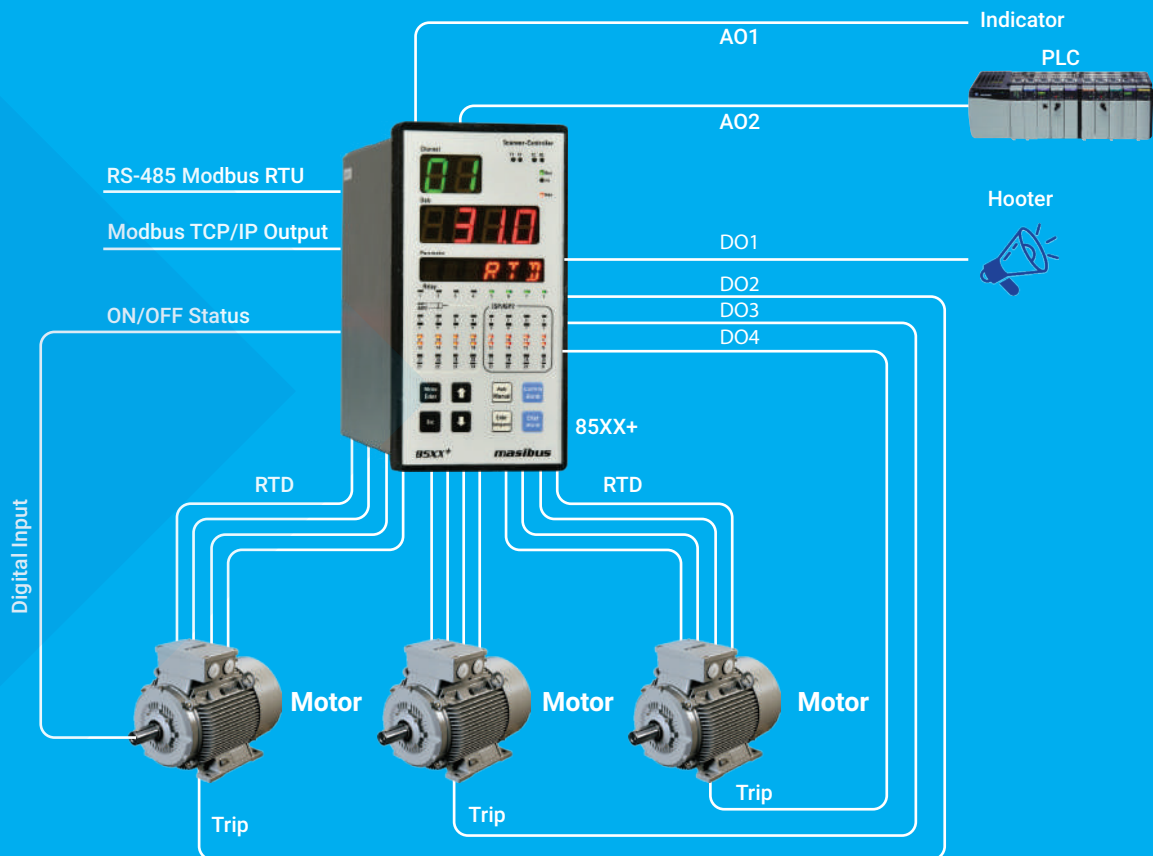

# 8040 Data Logger Applications



8040

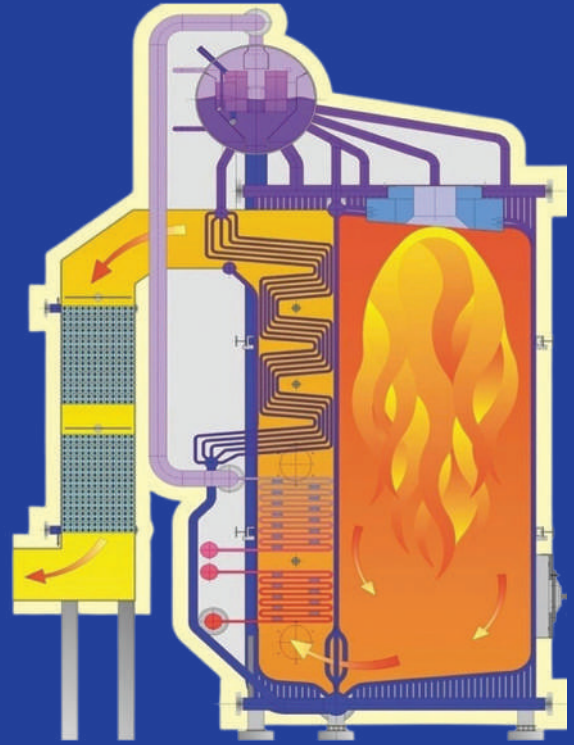

Boiler

## Benefits

- 128 Channel Universal Input
- Channel to Channel Isolation
- 3 Second update rate
- 32 MB Internal Memory
- Periodic & Event based Data Logging
- RS-485 & Ethernet Communication Port available

## Boiler Tube Temperature Monitoring System

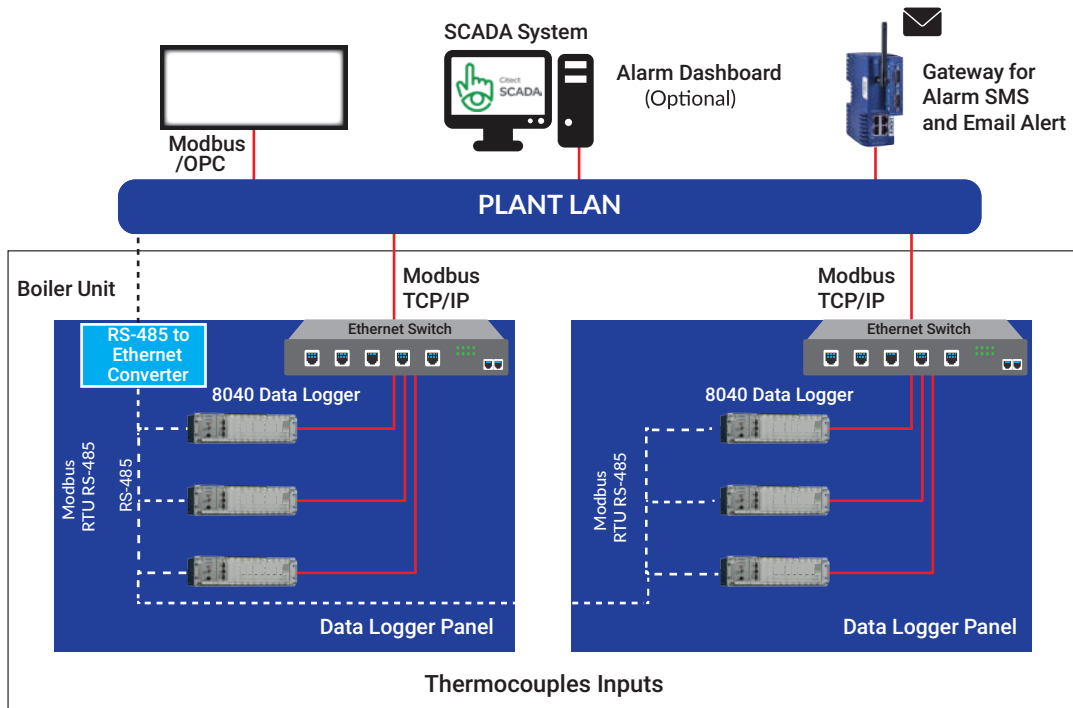

Avoid Unscheduled Outage

Availability & Tube Life

Reduce Secondary Damage

Identify Inefficient Heat Transfer

Increase Operating Profit

Plug & Play Solution

Easy Integration with Third Party System

High Price Performance Index



# Application Examples

## 8040 as 128 Channel Analog I/O Module for DCS/PLC

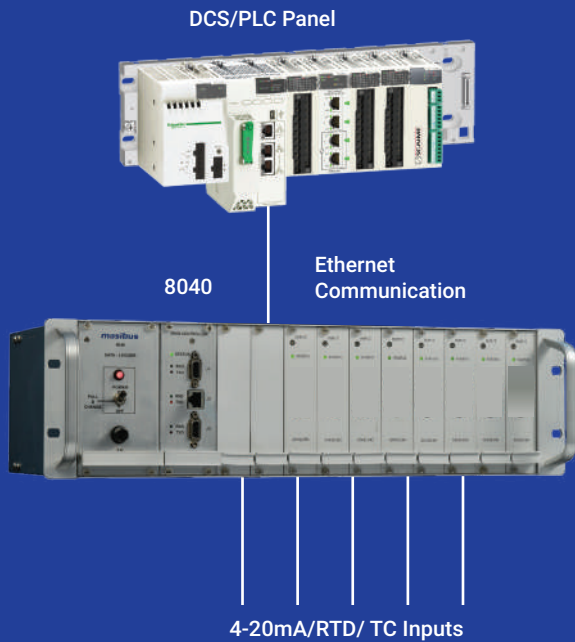

- It eliminates 16x8=128 channel AI card & associated power supply, rack, panels from DCS Panel
- Cost saving approximately 1 million INR

## Current & Temperature Monitoring of Multiple Motors in a Plant

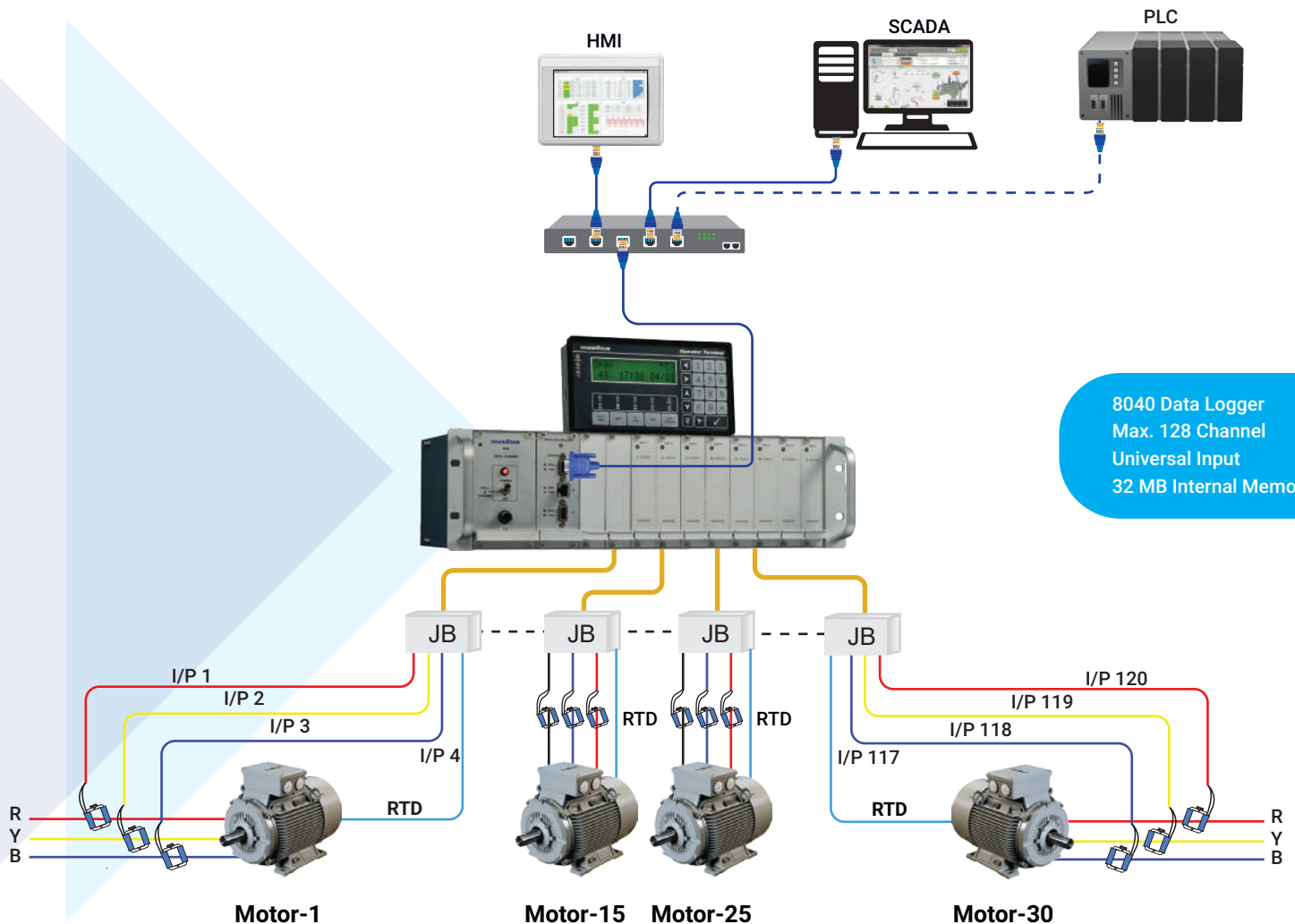

# Protocol Converter & Wireless Products



**MSG-21**  
(IIoT Gateway)



**MSC-ME-MS**  
(Modbus Serial to Modbus  
TCP/IP Data Concentrator/Gateway)



**MSC-ME-ZB**  
(Modbus-Zigbee to Modbus  
TCP/IP Data Concentrator/Gateway)



**MSC-ZB-RS**  
(RS-485 Serial to ZigBee  
Wireless Converters)



**HT16u**  
(Humidity-Temperature  
Smart Logger)



**HT16Ew**  
(Wireless RH-T Transmitter)



RH/T External  
Sensor Probe



**SBM-S-1225**  
(08-12-16-20 String Box Monitor)



**MSC-RS-RS**  
(Isolated RS-485 to RS-485 Repeater)



**MSC-RE-RS**  
(Modbus Serial to Modbus  
TCP/IP Protocol Converter)



**mUSB232**  
(USB to RS-232 Converter)



**mUSB485**  
(USB to RS-485 Converter)

# Zigbee Offerings

## What is Zigbee ?

Zigbee is a wireless technology developed as an open global market connectivity standard to address the unique needs of low-cost, low-power wireless IoT data networks. The Zigbee connectivity standard operates on the IEEE 802.15.4 physical layer radio specification and operates in unlicensed radio band 2.4 GHz.

## Zigbee Protocol Features Include

- Support for multiple network topologies such as point-to-point, point-to-multipoint and mesh networks
- Low duty cycle - Provides long battery life
- Low latency time
- Direct Sequence Spread Spectrum (DSSS)
- Up to 65,000 nodes per network
- 128-bit AES encryption for secure data connections
- Collision avoidance, retries and acknowledgement

Zigbee signal range upto 100 meters indoor and upto 1 KM outdoor with clear line-of-sight (LoS) without obstacles. RF range extension also possible via adding Zigbee repeaters in the existing network (Mesh network)



**MSC-ME-ZB**  
(Modbus-Zigbee to Modbus  
TCP/IP Data Concentrator/Gateway)



**MSC-ZB-RS**  
(RS-485 Serial to ZigBee  
Wireless Converters)



## MSC-ME-ZB

### Features

- Supports upto 64 Modbus RTU Slave devices on RS-485 & ZigBee
- Number of Master Ports (Modbus RTU): 1 RS-485 (Wired) & 1 ZigBee (Wireless) - Only one active at a time
- ZigBee Topology: Point-Point/Point-Multipoint/Mesh
- Modbus TCP/IP (ModNet) - 10/100Mbps- Auto detecting
- No. of Client supports on Modbus TCP/IP (ModNet) - Up to 15
- Supports up to 192 commands or 2048 Read/1024 Write Registers on Modbus

## MSC-ZB-RS

### Features

- Number of Ports: 1 RS-485 (Wired) & 1 ZigBee (Wireless)
- ZigBee Topology: Point-Point/Point-Multipoint/Mesh
- Router/Co-ordinator/Aggregator/Master/Slave configuration through MSC studio
- MSC-ZB-RS (Router/Slave) can connect to MSC-ME-ZB or MSC-ZB-RS (Co-ordinator/Master)
- Wireless range extension possible through router

# Application Examples

## Connecting 64 Modbus Devices Wirelessly Inside a Plant

100 Meter Indoor/ Upto 1 KM Outdoor (LOS)

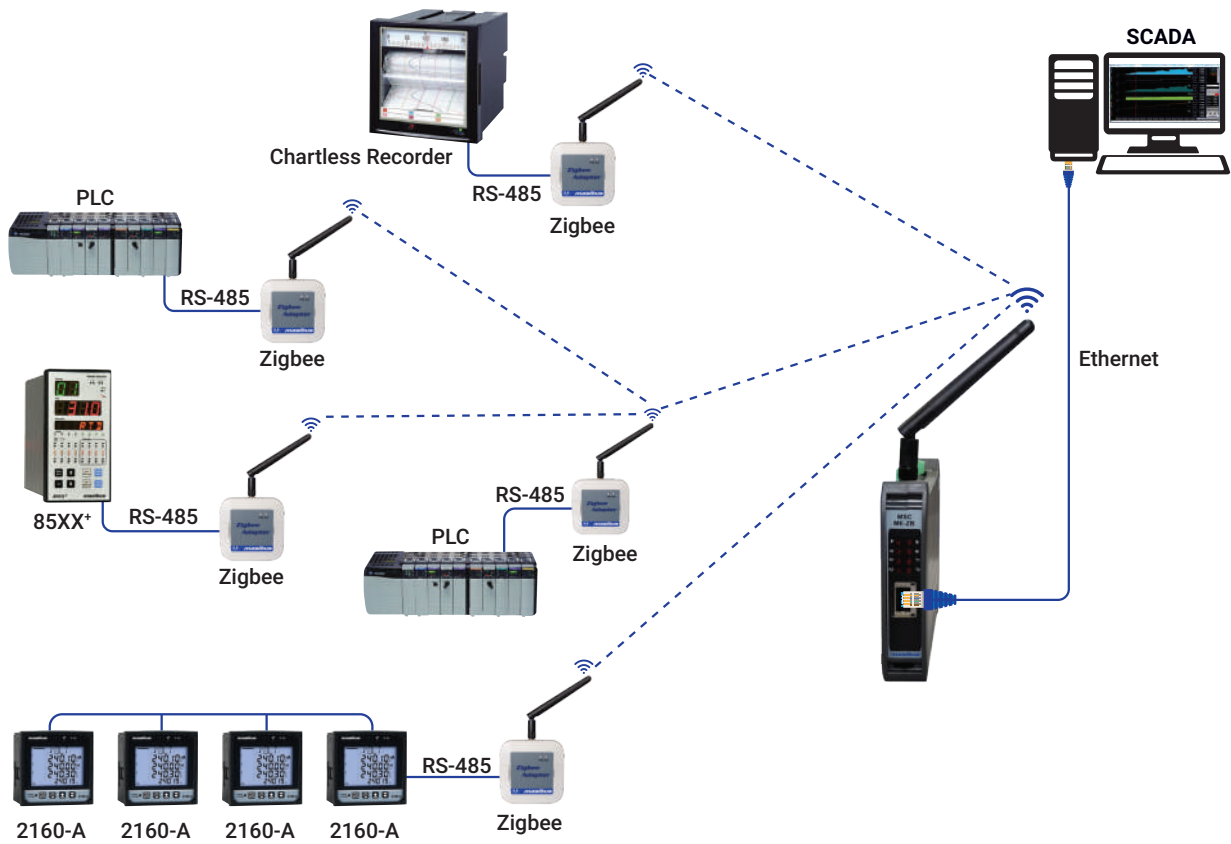

## Connecting Devices Wirelessly for EMS Solution

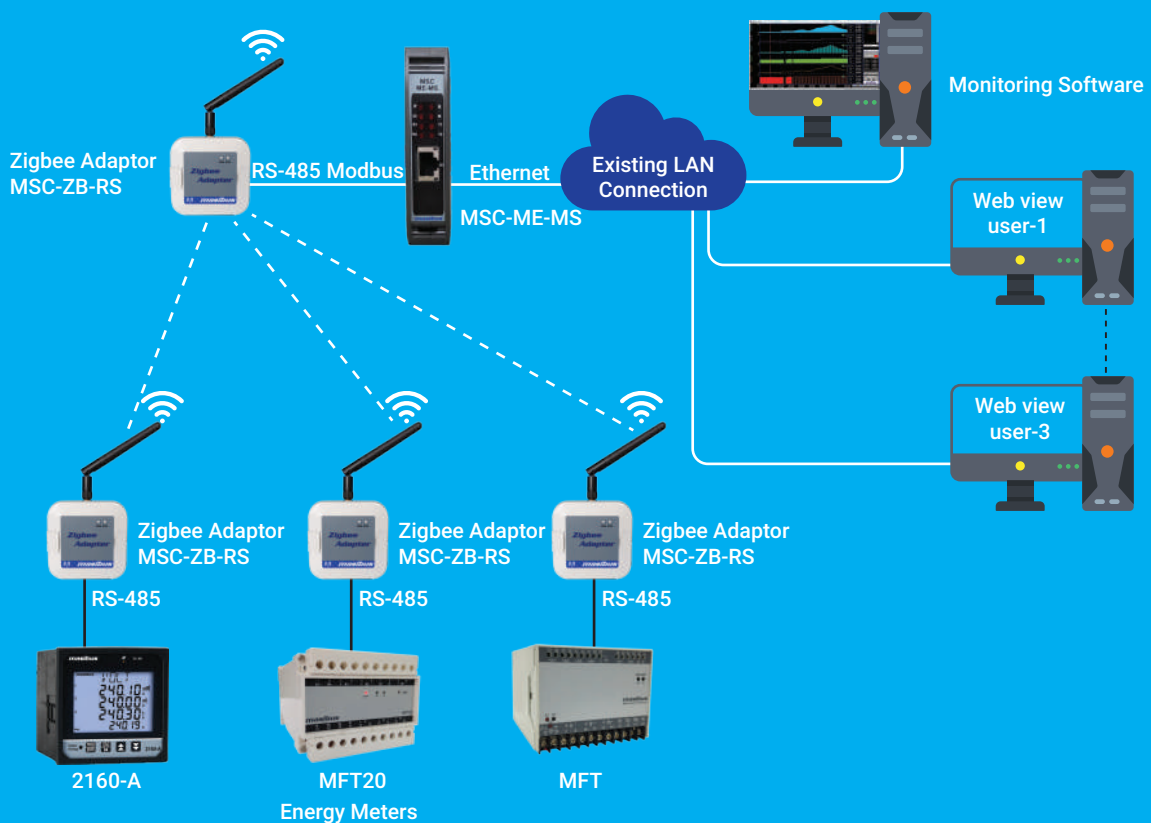



# HT16u- Humidity Temperature Smart Logger



## Features

- USB based HT16u with internal or external RH/T sensor with SS filter
- Temperature measurement -20 to 60 °C / -3.8 to 140 °F
- Humidity measurement 0 to 100 %
- Best in class accuracy @ 25°C +/-0.2°C temperature & +/- 2% RH
- Ultra low - battery power consumption with long life - CR2450 coin cell battery (1 Year @15min logging)
- Display battery status
- Logging start/stop - manual or pre-programmed (Auto) with pause facility
- SMART-HT free version - 3 devices in single report - Excel/PDF (Alarms & periodic data)
- SMART-HT license version - 10 Devices in single report/password protection in reports/21-CFR compliance with audit trails



HT16u

## Warehouse Layout - Room Temperature Mapping

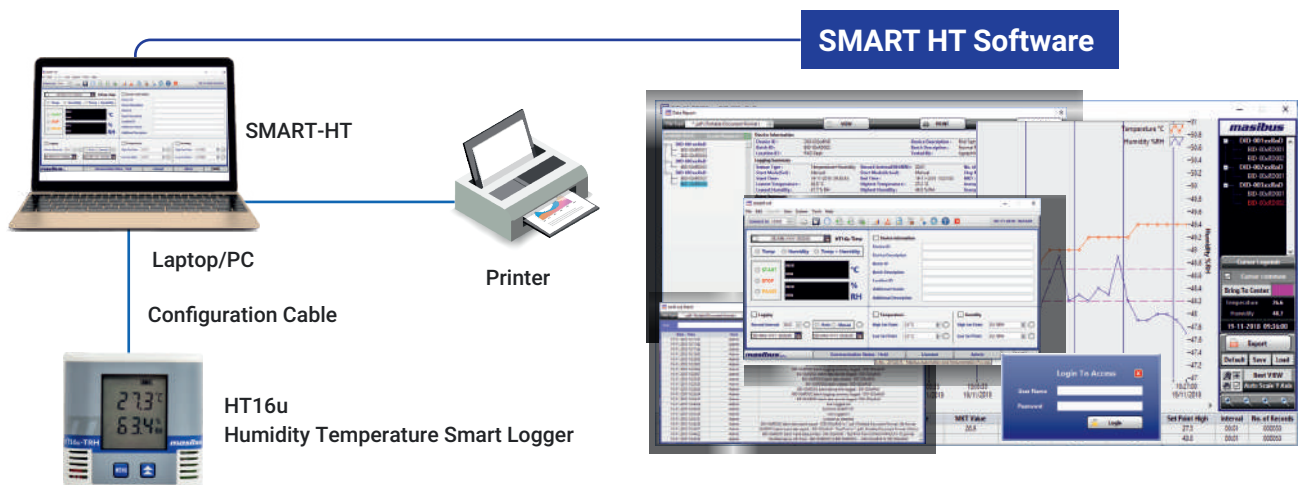

Pharma Industries

Clean Rooms & Warehouses

Food Industries

Cold Storages

Calibration Service Industries

# HT16Ew - Wireless Humidity and Temperature Transmitter



## Features

- Temperature & Humidity Measurements -20 to 60° T/ 0-100% RH
- Deep sleep wakeup transmit on 2.4 Ghz ZigBee Wireless
- Zero data loss from device to SCADA with data backfilling
- 12 HT16Ew can connect to one wireless receiver
- HT16Ew with rechargeable battery - 1 year @ 15 min log
- RTC display and synchronization with SCADA
- IP65 Enclosure for protection against dust and water
- Wireless receiver can connect to SCADA on DNP3 Ethernet



HT16Ew



RH/T External Sensor Probe

## Environmental Monitoring / Warehouse Monitoring

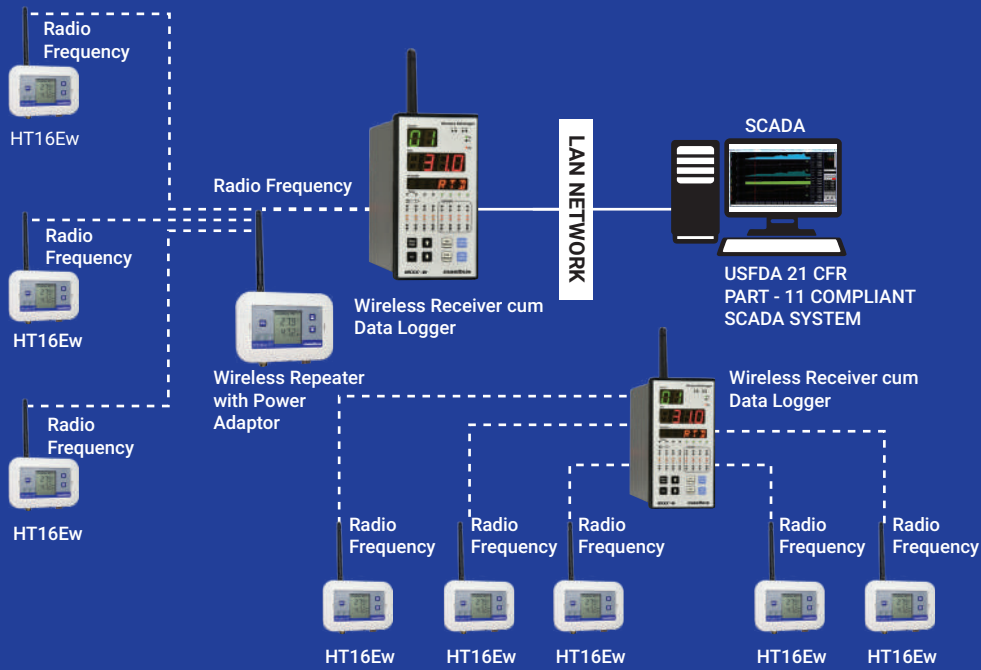

## Environmental Monitoring / Clean Room Monitoring

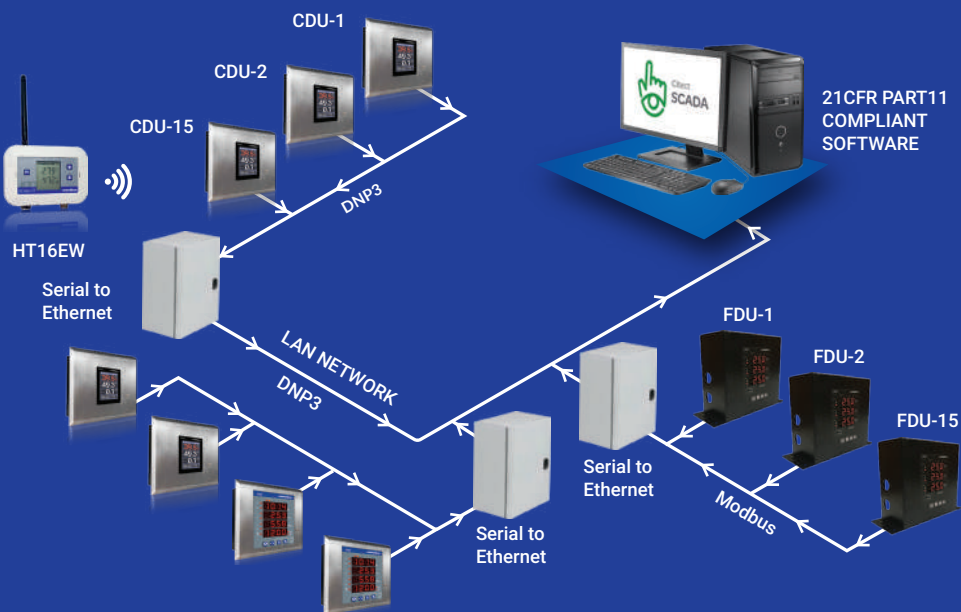

# Protocol and Media Converters

## Protocol Converters



**MSC-ME-MS**  
(Modbus Serial to Modbus  
TCP/IP Data Concentrator/Gateway)

### Features

- It converts **Modbus Serial to Modbus TCP/IP**
- Supports max. upto 64 Modbus RTU slave devices on RS-485
- No. of RS-485 ports (Modbus RTU Master): 2 (Only one active at a time)
- Modbus TCP/IP (ModNet) - 10/100Mbps- auto-detecting
- No. of client supports on Modbus TCP/IP (ModNet) - Up to 15
- Supports upto 192 Modbus commands
- 2048 Read/1024 write registers on Modbus

### Features

- Supports max. upto 247 Modbus RTU slave IDs.
- No. of RS-485 ports (Modbus RTU master): 1 No.
- Modbus TCP/IP (ModNet) - 10/100Mbps- Auto detecting
- No. of client supports on Modbus TCP/IP (ModNet) - Up to 4 No.
- Not required any Modbus query Mapping/Configuration



**MSC-RE-RS**  
(Modbus Serial to Modbus  
TCP/IP Protocol Converter)

## Media Converters

### Features

- RS-485 half duplex communication
- Communication speed (Baud rate) 1200 - 115200 bps
- Auto baud rate detection
- Signal boost up to 1200m (Depends upon baud rate)
- Maximum 31 RS-485 nodes per repeater
- 120Ω termination resistor selection
- Isolation 1500VAC RMS



**MSC-RS-RS**  
(Isolated RS-485 to RS-485 Repeater)



- Convert the signals to RS-232
- Port: 9 PIN DB male connector
- Output - RS-232 full handshaking



**mUSB232**  
(USB to RS-232 Converter)



**mUSB485**  
(USB to RS-485 Converter)

- Convert the signals to RS-485 level
- Outputs: D + / D -
- Maximum 32 nodes
- 120Ω termination resistor selection

## MSC-ME-MS as Modbus Gateway OR MSC-RE-RS as Modbus Protocol Converter

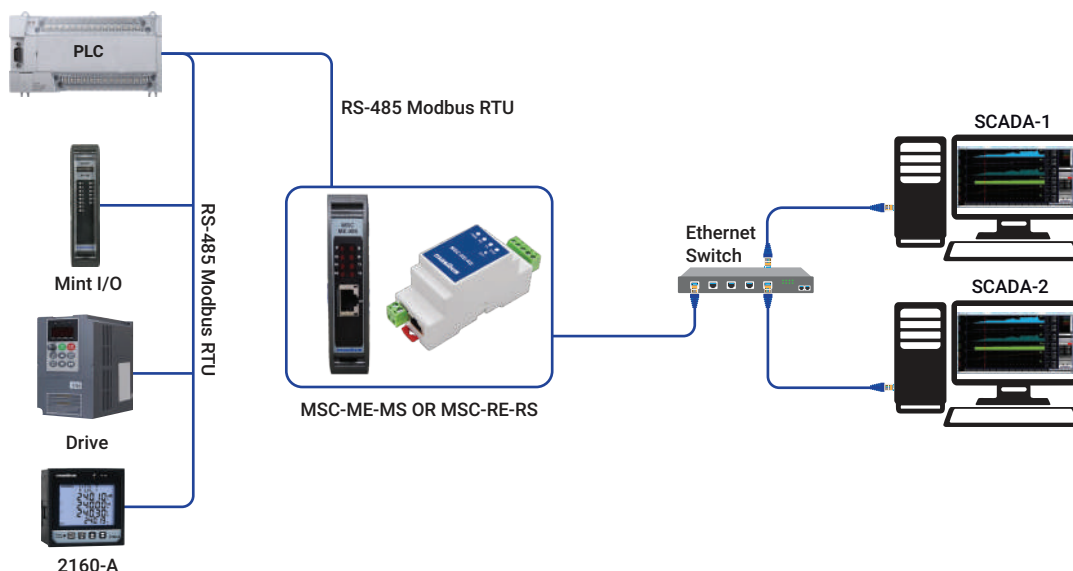

# String Box Monitor (With Wired & Wireless)



## String Box Monitor with Wireless ZigBee

### Features

- 8/12/16/20 Channels String Inputs
- Built-in Shunt based DC Current Monitoring
- Measurement on the negative side string inputs
- Compatible with system voltage levels of up to 1500 VDC
- 02 RTD Sensor inputs for Temperature Monitoring
- 02 Digital inputs for DC disconnect and power SPD status
- -10°C to 70°C Operating temperature
- Input power supply: 18-36 VDC or 5 VDC
- 01 No. of RS-485 (2-wired) communication port
- On-board Wireless ZigBee communication module
- Modbus-RTU communication port
- Wireless ZigBee communication protocol
- Effortless communication with any SCADA system

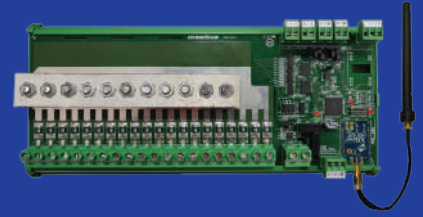

SBM-S-1225 (Wireless)



SBM-S-1225 (Wired)

## String Box Monitor - Connection/Configuration

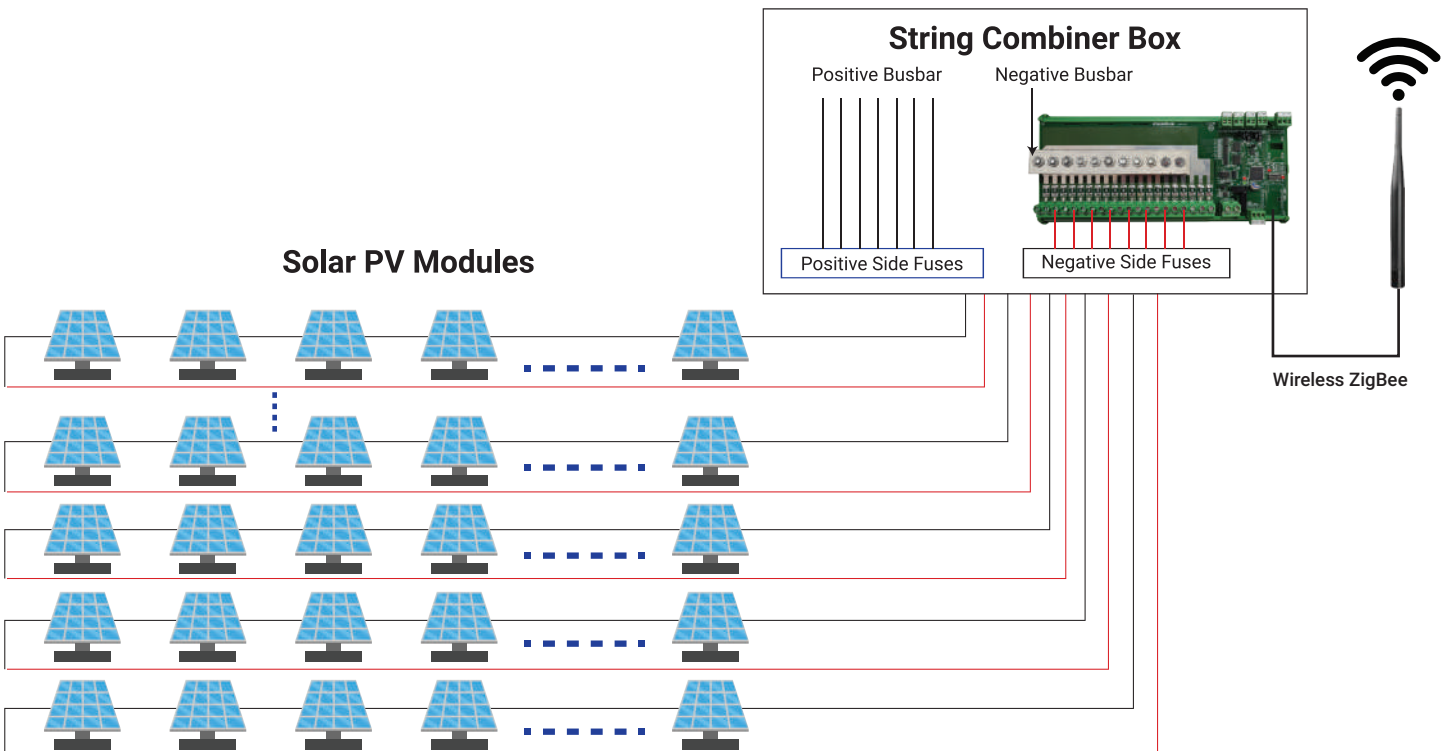



# Application Examples

## Layout –String Combiner Box to Control Room Communication

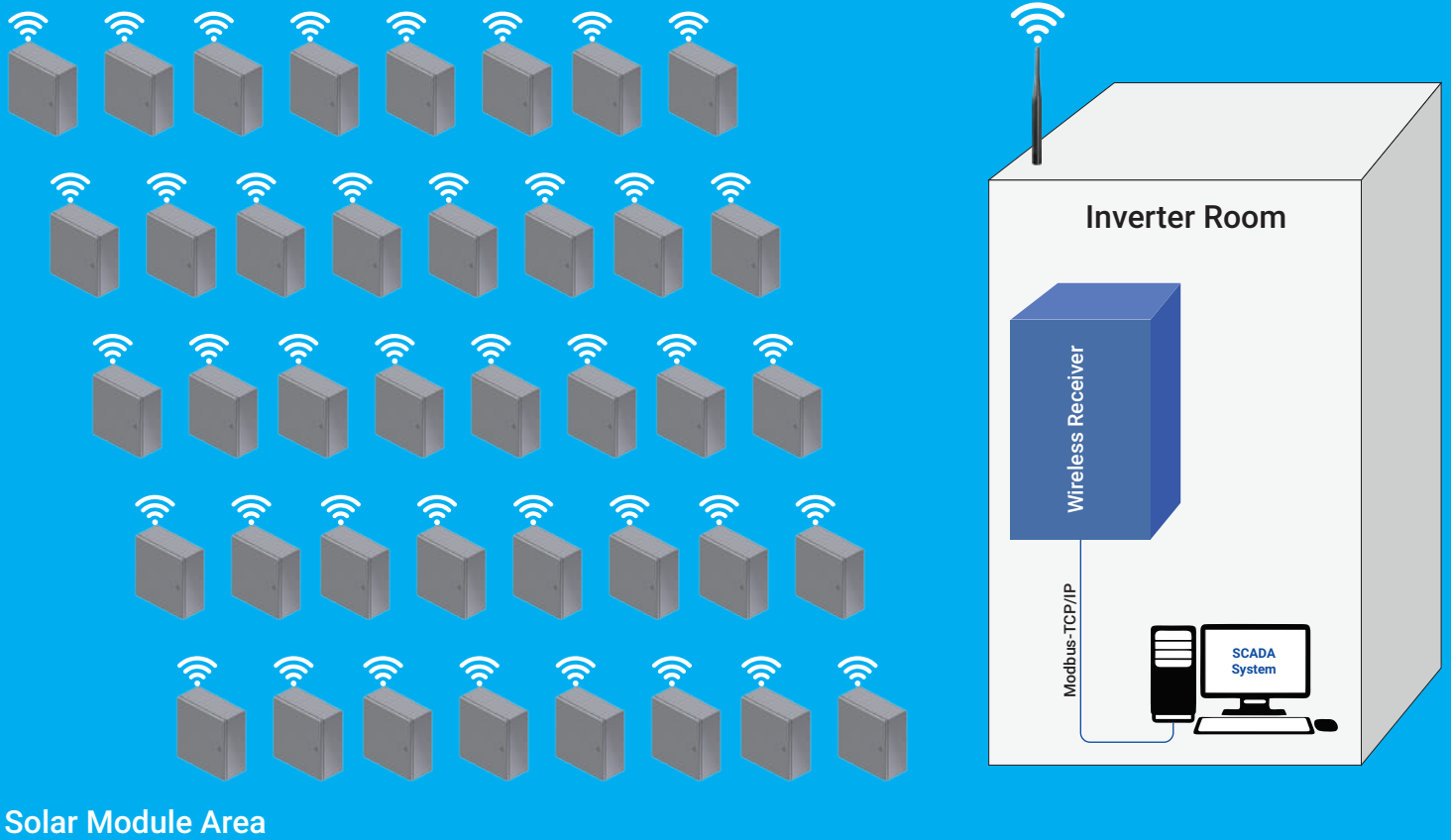

1

44 nos. Of String Combiner Boxes in 5MW Block

2

Wireless Communication From SCB to Inverter Rooms

3

String Data Available over Modbus TCP/IP @ Receiver

4

Distance - 500+ Meters

5

Zigbee Mesh Network

# MSG-21 - IIoT Gateway Solution for any Modbus Slave Devices



## Features

- 4G cellular or Ethernet (WAN) connectivity for MQTT broker
- Web server-based configuration for MQTT, Ethernet, Modbus RTU and Modbus TCP/IP
- Configurable MQTT (JSON) frame format
- Modbus TCP/IP Server Connectivity for HMI/PLC/SCADA
- Modbus TCP/IP client to read Modbus servers on ethernet
- Modbus RTU master to read Modbus RTU slaves on RS-485
- On board 2 Digital Inputs & 2 Digital Outputs operate remotely via SMS & MQTT
- Read Registers - Modbus RTU 512 Nos. & Modbus TCP/IP 256 Nos.
- Device Connection - Modbus RTU 32 Nos. & Modbus TCP/IP 8 Nos.
- Built-in 16MB memory to support back filling of time stamped data to server in the event of network failure



MSG-21

## IIoT System for Remote Field Data Monitoring

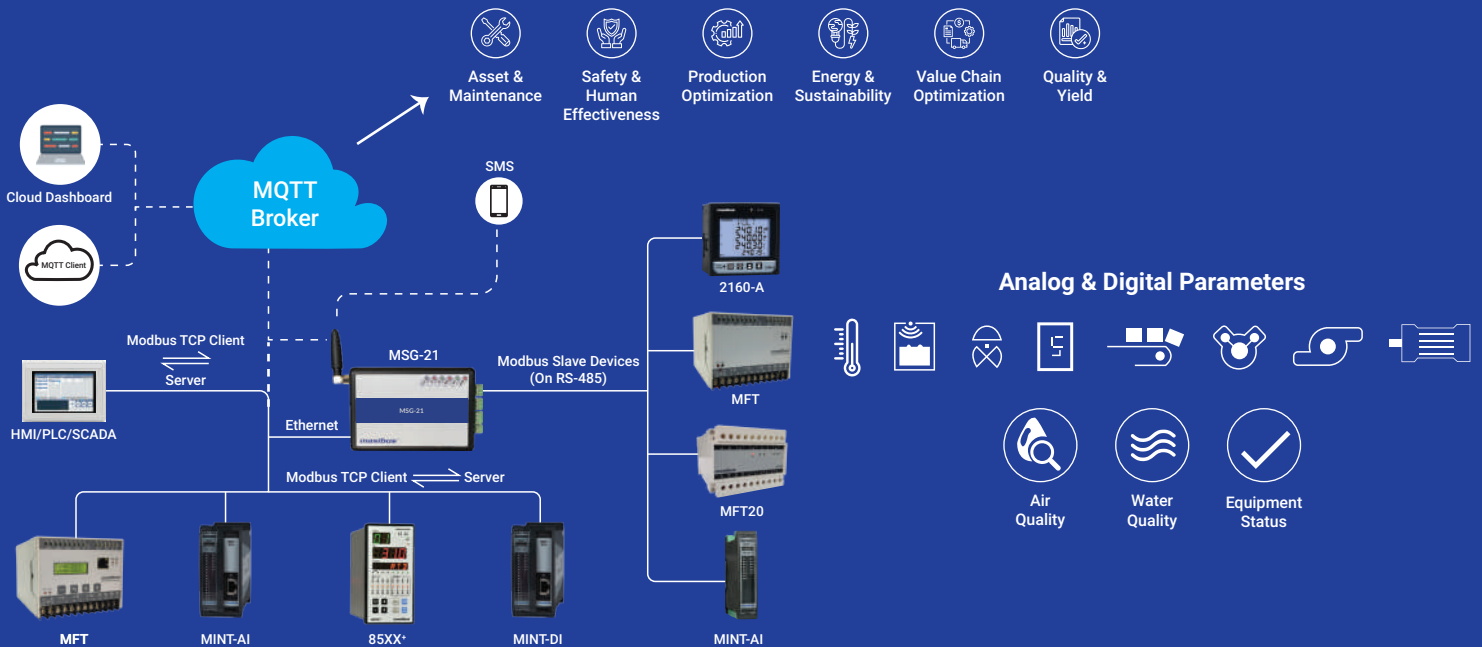

## Remote Energy Monitoring Of Electrical Systems



PCC Panel / Switchgear Panel

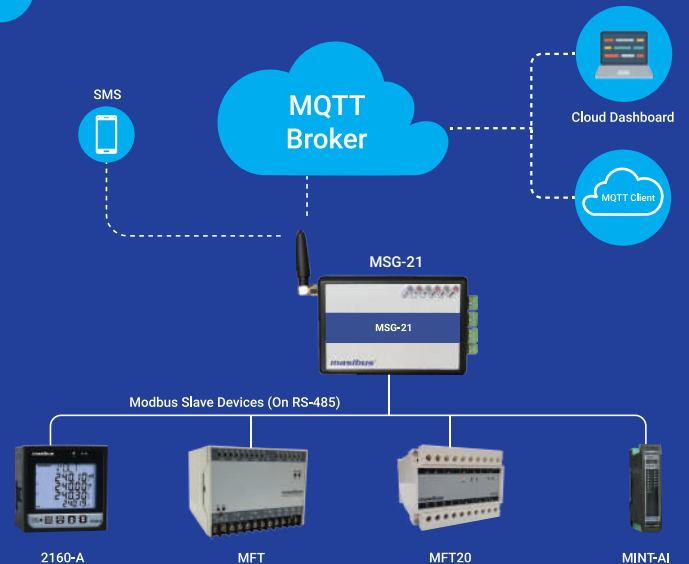

# SMART 2.0 Software Tool for Reports, Alarms & Dashboards

Web Based | No Coding | 21-CFR Part-11 Compliance

## Features

- **Data Connector:** Modbus RTU, Modbus TCP/IP, OPC DA/UA
- **Masibus Device Templates:** All masibus devices connectivity (85XX+, MINT IO's, Bargraph, Controllers, Energy Meters, etc.)
- **3<sup>rd</sup> Party Devices:** Any device with Modbus RS-485/Modbus TCP-IP support
- **Server Compatibility:** On-Premises / VM
- **Data Monitoring:** Real time and Historical data monitoring
- **Dashboards Screens:** KPI dashboards: Tabular, Pie/Donut, Gauge, Line Chart, Bar Graph
- **Reports:** Daily, Weekly, Monthly, Yearly Reports
- **Alarms:** Alarm generation based on L/L-L/H/H-H set points
- **Trends:** Live & Historical trends
- **Email:** E-mail reporting and automatic scheduling
- **21-CFR Part-11 User Management:** Optional
- **Licensed software** - 64/128/256/512/1024 tags supports

## Key Specifications

- Suitable for On-premises Server/PC and Virtual Machine
- Supports up to 25 dashboards
- Supports up to 50-tags per dashboard
- Connectivity to all Modbus devices
- 21-CFR Part-11 user management
- 5 Web View Clients



## Data Monitoring & Logging

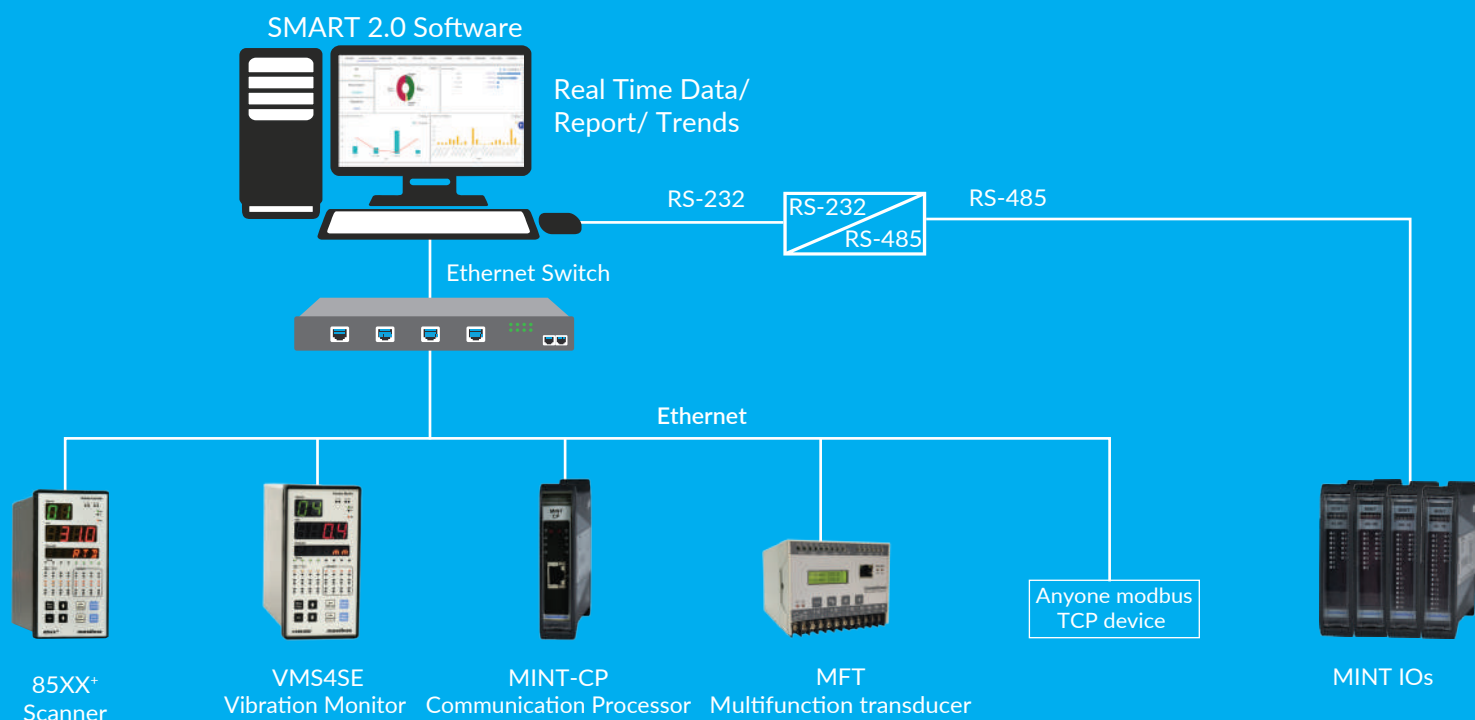

# **masibus**<sup>®</sup>

**A Sonepar Company**

## **Masibus Automation And Instrumentation Pvt. Ltd.**

### **Gandhinagar**

**Address:** B-30, G.I.D.C. Electronic Estate,  
Sector - 25, Gandhinagar - 382 024,  
Gujarat, India  
**E-mail:** sales@masibus.com  
**Ph. No.:** +91 9662042824

### **Goa**

**Address:** C-6, Phase 1-A, Verna Industrial  
Estate, Verna, Salcette - 403722,  
Goa, India  
**E-mail:** sales@masibus.com  
**Ph. No.:** +91 9822135796

### **Sharjah**

**Address:** A2-102, SAIF Zone, PO Box  
120145 Sharjah, UAE  
**E-mail:** sharjahall@masibus.com  
**Ph. No.:** +971 65574650

### **Bengaluru**

**E-mail:** sales@masibus.com  
**Ph. No.:** +91 8732971943

### **Chennai**

**E-mail:** sales@masibus.com  
**Ph. No.:** +91 9725154195

### **Delhi**

**E-mail:** sales@masibus.com  
**Ph. No.:** +91 9909949742

### **Hyderabad**

**E-mail:** sales@masibus.com  
**Ph. No.:** +91 9909949062

### **Kolkata**

**E-mail:** sales@masibus.com  
**Ph. No.:** +91 9512003359

### **Mumbai**

**E-mail:** sales@masibus.com  
**Ph. No.:** +91 9689937234

### **Pune**

**E-mail:** sales@masibus.com  
**Ph. No.:** +91 9689937234

**E-mail:** sales@masibus.com  
**Website:** www.masibus.com

*Sales Service: TOLL FREE (India)*

**1-800-233-2273**

## **Sonepar India Pvt. Ltd.**

### **Gurgaon**

**Address:** Plot No. 229/239, Village -  
Kherki Daula, Sector 76, Gurugram,  
Haryana, 122004, India

### **Kolkata**

**Address:** 503, Block 4B, Ecospace  
Business Park, Newtown, Rajarhat,  
Kolkata, West Bengal, 700160, India

### **Chennai**

**Address:** Plot No. 1, Gokul Garden,  
Melnallathur, Thiruvallur, Chennai,  
Tamil Nadu, 602002, India

### **Aurangabad**

**Address:** FP-42, Five Star Industrial Area,  
Shendra MIDC, Aurangabad,  
Maharashtra, 431201, India

### **Panchkula**

**Address:** Plot No. 263, Industrial Area,  
Phase-II, Panchkula, Haryana,  
134113, India

### **Bhubaneswar**

**Address:** Plot No. 443, 1st Floor,  
Saheed Nagar, Bhubaneswar,  
Odisha, 751007, India

**E-mail:** communications@soneparindia.com  
**Website:** www.soneparindia.com