User's Manual

UT-94 Universal Transmitter



Masibus Automation and Instrumentation Pvt. Ltd.

B/30, GIDC Electronics Estate,
Sector-25, Gandhinagar, Gujarat, India
Phone : +91-79-23287275-77
Fax : +91-79-23287281
Email: support@masibus.com
Web: www.masibus.com

Contents

1.	Introduction.....	4
1.1	Ordering Code	4
2.	Installation	5
2.1	Environment:.....	5
2.2	Mounting:	5
2.3	Installation Dimensions:	5
2.4	Removal:.....	5
3.	Front Panel.....	6
4.	Dimensions.....	7
5.	Terminal Position Detail:	8
6.	Menu Function List	9
7.	Parameter Description.....	10
8.	Menu Guideline	11
8.1	Program Menu	11
8.2	Configuration Menu.....	11
8.3	Calibration Menu	12
8.4	Software Version.....	12
9.	Menu Layout.....	13
10.	Calibration Procedure.....	15
10.1	Ambient Calibration:	15
10.2	Input Calibration:.....	15
10.3	Output Calibration	16
11.	Modbus Detail:	17
11.1	Configuration parameter Read – write	17
11.2	Configuration parameter Read:.....	18
12.	Specifications	20
12.1	Input Specification:	20
12.2	Display & Keys:.....	21
12.3	Output:	21
12.4	Retransmission Output	21
12.5	Communication:.....	21
12.6	Power Supply	22
12.7	Isolation (Withstanding voltage):.....	22
12.8	Insulation resistance:	22
12.9	Physical:	22
12.10	Environmental:.....	22
12.11	Advance Option:	22
13.	Relay Logic:.....	23
14.	Appendix:	24
14.1	Internal Jumper Setting For Retransmission Output	24
14.2	Troubleshooting:	25
14.3	Load connection	25

SAFETY PRECAUTIONS

To ensure that the device can be operated safely and all functions can be used, please read these instructions carefully.



Caution: Never carry out work when the Power is turned on, this is dangerous.

Installation and startup must be carried out by qualified personnel only. The relevant country-specific regulations (e.g., VDE, DIN) must also be observed.

Before startup it is particularly important to ensure:

Terminal wiring:

Check that all cables are correctly connected according to the connection diagram

- The mains have been connected correctly and protection is provided against electric shock.
- The device can be switched off outside the power supply according to EN 60950 regulations (e.g., by the line protection on the primary side)
- All supply lines have sufficient fuse protection and are of correct size.
- All output cables are of correct size for the maximum device output current or have separate fuse protection.
- Sufficient convection is ensured.
- After installation the terminal area must be covered to provide sufficient protection against unauthorized access to live parts.

This is ensured by installing the device in the control cabinet or distributor box.

1. Introduction

This is a micro-controller based Universal Transmitter which retransmits the Universal Inputs given, into the required Voltage or current. This instrument provides isolation at 4 levels:

- a) Between input and Power supply
- b) Between output and Power supply.
- c) Between input and output.
- d) Output to Output

1.1 Ordering Code

Model UT – 94													
Input Type		Power Supply		No of O/P		O/P type-1		O/P type-2		Relay O/P		Communication	
X		XX		X		X		X		X		X	
1	E	U1	85-265VAC/ 100-300VDC	1	One	1	4-20mA	0	None	N	None	N	None
2	J	U2	18-36VDC	2	Two	2	0-20mA	1	4-20mA	Y	Yes	Y	RS-485
3	K					3	1-5VDC	2	0-20mA				
4	T					4	0-5VDC	3	1-5VDC				
5	B					5	0-10VDC	4	0-5VDC				
6	R					S	Special	5	0-10VDC				
7	S							S	Special				
8	N												
9	Pt-100												
C	4-20mA												
D	0-20mA												
E	1-5VDC												
F	0-5VDC												
G	0-10VDC												
W	0.4 - 2 VDC												
X	mV (-10-500 mV)												
Y	0-2 VDC												
Z	Pot (0-2000 ohms)												
S	Special												

2. Installation

2.1 Environment:



Caution: Do not install the unit where it is subjected to continuous vibration. Do not subject the unit to physical impact.

2.2 Mounting:

The unit can be snapped onto all DIN rails according to EN 60715. The device must be mounted horizontally (input terminal blocks facing downwards)

2.3 Installation Dimensions:



To ensure sufficient convection, a minimum spacing of 3 cm is required.

- 1) Place the module with the DIN rail guide way on the bottom edge of the DIN rail and then snap it downwards.
- 2) The housing is mounted on the DIN rail by swiveling it into place.
- 3) As air vents are provided on the top and bottom part of the unit, the (horizontal) mounting arrangement allows good vertical air circulation.



Vertical mounting arrangement of multiple units must be avoided.

2.4 Removal:

Release the snap-on catch using a screwdriver and then detach the module from the bottom edge of the DIN Rail.

3. Front Panel

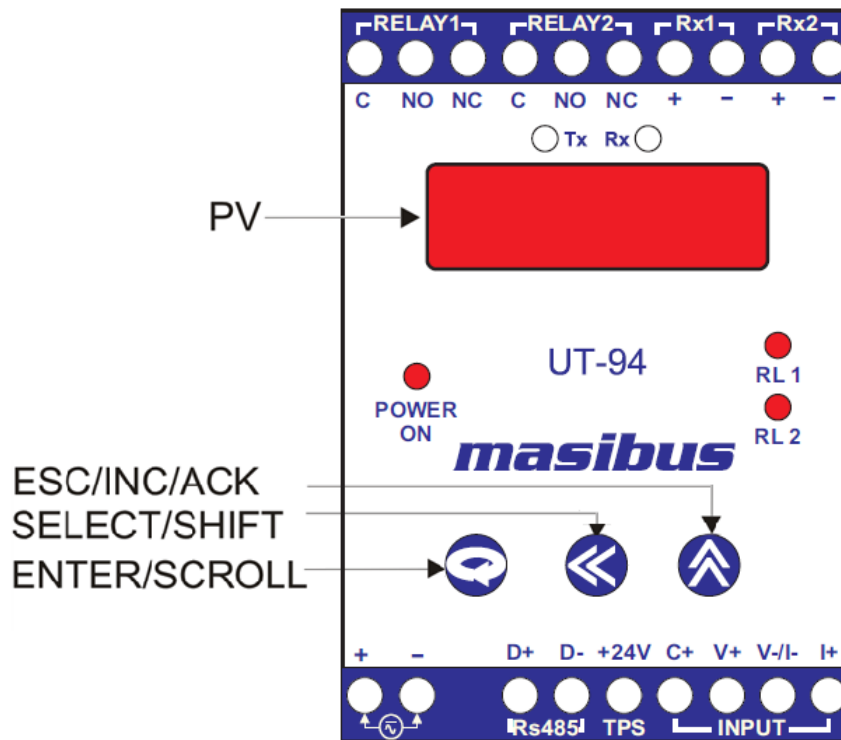

ENTER / SCROLL Key – This key is used to start menu, scroll through the menu and save values.

SEL / SHIFT Key – This key is used to select the menu options, for shifting the digit of the selected parameters and for ambient display in Run Mode for TC Input.

ESC / INC/ ACKNOWLEDGEMENT Key – This key is used to revert back to the parent menu from the sub menu levels and Increment the selected digit. This key is also used as Acknowledgement key for Alarm/trip type relay.

4. Dimensions

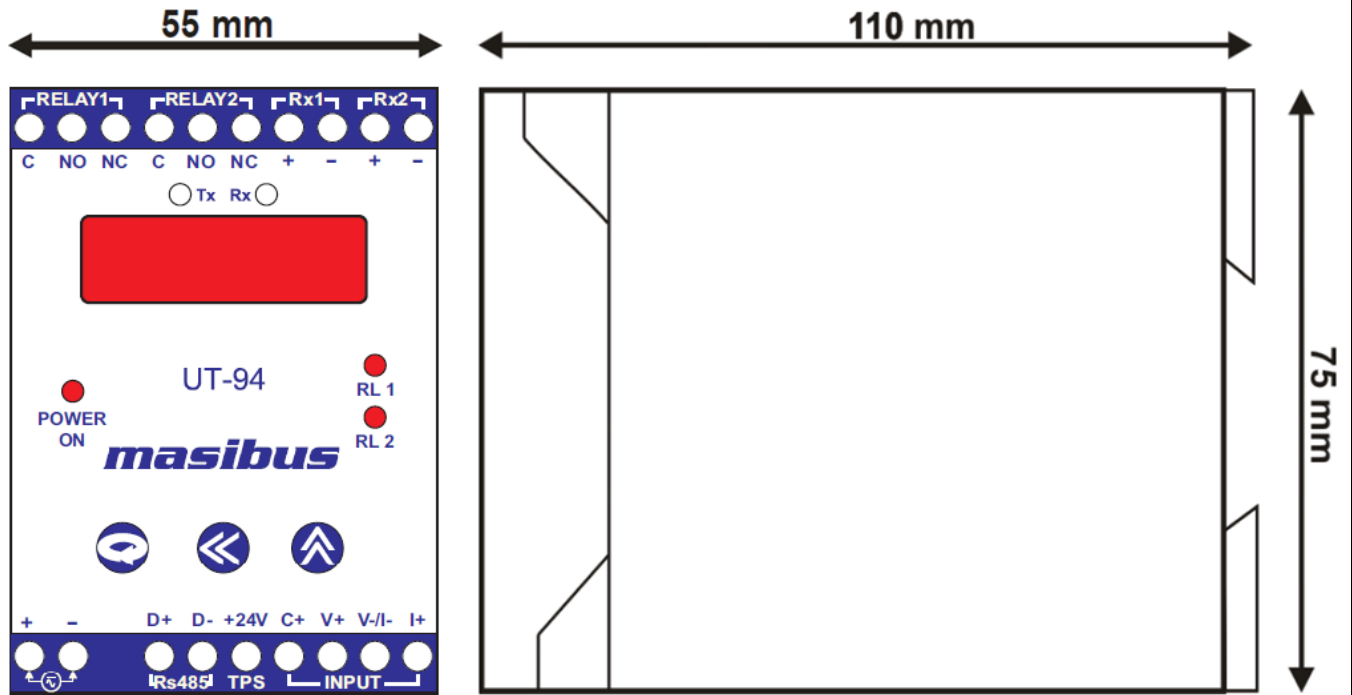

5. Terminal Position Detail:

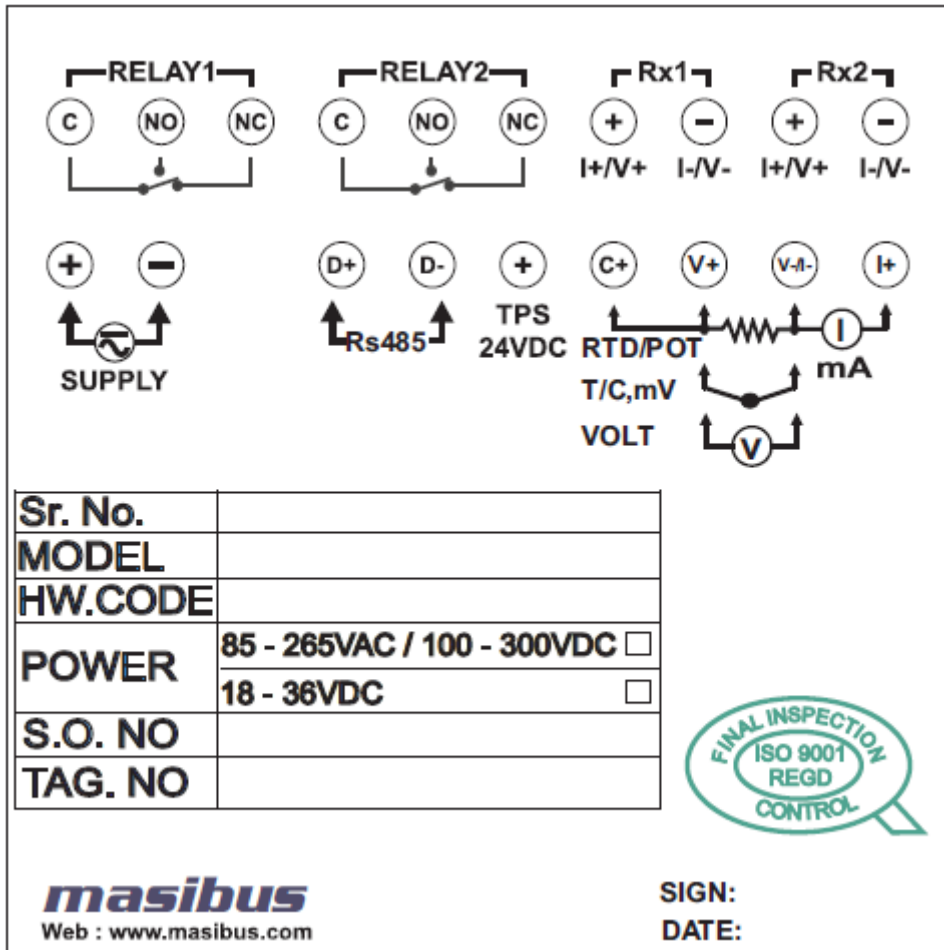

6. Menu Function List

PROG	ST-1	Set point value for relay-1
	HY-1	0 TO 100
	ST-2	Set point value for relay-2
	HY-2	0 TO 100

CONF	INP	IPTY	T/C: E, J, K, T, B, R, S, N. RTD: Pt100 3-WIRE, Linear: mV(-10 - 500mV), Pot(0-2000 Ohms), 0-2V, 0.4-2V, 0-5V, 1-5V, 0-10V, 0-20mA, 4-20mA.		
		Zero	Input Zero Value		
		Span	Input Span Value		
		DP	0 - 3		
		UNIT	°C, °F, °K		
		INLO	For I/P Type: mV(-10 - 500mV), Pot(0-2000 Ohms)		
		INHI	INHI - INLO >10		
	OUT	rtr	OPNO	1, 2	
			OPTY	4 -20mA, 0 -20mA, 1-5V, 0-5V, 0-10VDC	
			Op Z	% of Output for scaling (O/P Zero limit will be limited to this configured 0-30 % of O/P Span)	
			OP S	% of output for scaling (O/P Span limit will be limited to this configured 70-100 % of O/P Span)	
			OPLO	* % of Output (O/P Low limit will be limited to this configured 0-25 % of O/P Span)	
			OPHI	* % of output (O/P Hi limit will be limited to this configured 75-100 % of O/P Span)	
			OPSC	UPSC/DNSC	
			DIR	DIR/REV	
		rely	RLNO	1, 2	
			OPSE	UP,dw	
			LOGC	HI,low	
			CAL	ALARM,TRIP,OPEN	
			LTCH	YES,NO	
		COM	SRNO	1-247	
			BAUD	4800,9600,19200	
		ADV	FILT	0 - 60 Sec	
			FSET	Give Default password for factory settings	
	PASS		Change Password		
	SQRT		YES/NO		
	TOUT		10-300 SEC		
CAL	AMB				
	INP	SPAN			
		ZERO			
	OUT	OPNO	1, 2		
		ZERO			
SPAN					
VER	Software Version				

* Output will not be scaled but only limit to this configured % of output.

7. Parameter Description

CONF	Configuration Mode
CALI	Calibration Mode
INP	Input type Parameter Settings
OUT	Output type Parameter Settings
ADV	Advance Parameter Settings
VER	Software Version
AMB	Ambient
IPTY	Input Type
Zero	Input Zero
Span	Input Span
DP	Decimal Point
UNIT	Engineering Units
INLO	I/P LO (For I/P : mV,Pot)
INHI	I/P HI (For I/P : mV,Pot)
OPNO	Output Channel No
OPTY	Output Type
OP Z	% of O/P Zero for scaling
OP S	% of O/P Span for scaling
OPLO	* % of the O/P Zero range
OPHI	* % of the O/P Span range
OPSC	Up/down Scale one sensor open
DIR	Forward/Reverse Output
FILT	Digital Filter
FSET	Factory Setting
PASS	Password
SQRT	Square root
TOUT	Time out From the Menu (10 to 300 Sec)
OVER	Input Signal above Span
UNDR	Input Signal below Zero
OPEN	Sensor Burned
WAIT	Calibration In Process
Ferr	Factory setting Error
rely	Relay
RLNO	Relay number
OPSE	Open sensor
LOGC	Relay control Logic
C AL	Configure alarm
LTCH	Latch
rtr	Retransmission
SRNO	Serial No
BAUD	Baud Rate
ST-1	Set point for relay one
HY-1	Hysteresis for Relay one
ST-2	Set point for Relay two
HY-2	Hysteresis for Relay two

8. Menu Guideline

8.1 Program Menu

- Set point for relay-1.
- Hysteresis for relay-1.(0-100)
- Set point for relay -2.
- Hysteresis for relay-2.(0-100)

8.2 Configuration Menu

8.2.1 Input Selection

- Input Type Selection
- Input Zero Setting
- Input Span Setting
- Decimal Point Setting (Only for Linear Inputs)
- Engineering Unit Setting (°C, °F or °K, only for TC and RTD inputs)

8.2.2 Output Selection

8.2.2.1 Retransmission:-

- Output Channel Selection for Setting (1 or 2)
- Output Type Selection
- (0 –20 mA, 4-20 mA, 0-5 V, 1-5 V, 0 – 10 V that will be provided as factory setting)
- Output Zero Setting (Minimum 0.0 – 30.0 %) for scaling.
- Output Span Setting (Maximum 70.0 - 100.0 %) for scaling.
- Output Low Setting (Minimum 0.0 – 25.0 %)
- Output High Setting (Maximum 75.0 - 100.0 %)
- Output Upscale / Downscale Setting for OPEN input
- Output direction setting (Direct / Reverse)

8.2.2.2 Relay:-

- Relay No. Selection for Setting purpose (1 or 2)
- Relay Upscale / Downscale Setting for OPEN input
- Selection for Operating relay above (high) or below (low) set point.
- Selection of relay type i.e. Alarm or Trip or Open.
- Latch selection whether “Latch yes” or “No Latch” only if alarm type relay is selected.

8.2.2.3 Communication:-

- Sr. No. Selection for setting purpose (1 to 247)
- Baud Rate Selection for Setting Purpose (4800, 9600, 19200)

8.2.3 Advance Options

- Digital filtering (Range: 0 to 60.0 second)
- Factory Setting- To retrieve the factory setting.
- Password Setting
- Square Root (No / YES, for Linear inputs only)
- For Square Root, Output will be come as per
- $PV = \text{SQRT} [\{ (\text{input reading} - \text{config. IP Zero}) / (\text{config. IP Span} - \text{Config. IP Zero}) \} * \text{Config. OP Span}] + \text{Config. OP Zero}$
- Time Setting for Come back to RUN mode on no key operation (Range: 10 to 300 second)

8.3 Calibration Menu

- **Ambient Calibration** (For TC only)
- **Input Calibration**
 - Input Zero Calibration
(For RTD only)
 - Input Span Calibration
- **Output Calibration**
 - Output Channel Selection for calibration
 - Output Zero Calibration
 - Output Span Calibration

8.4 Software Version

- Version Number of the Software

9. Menu Layout

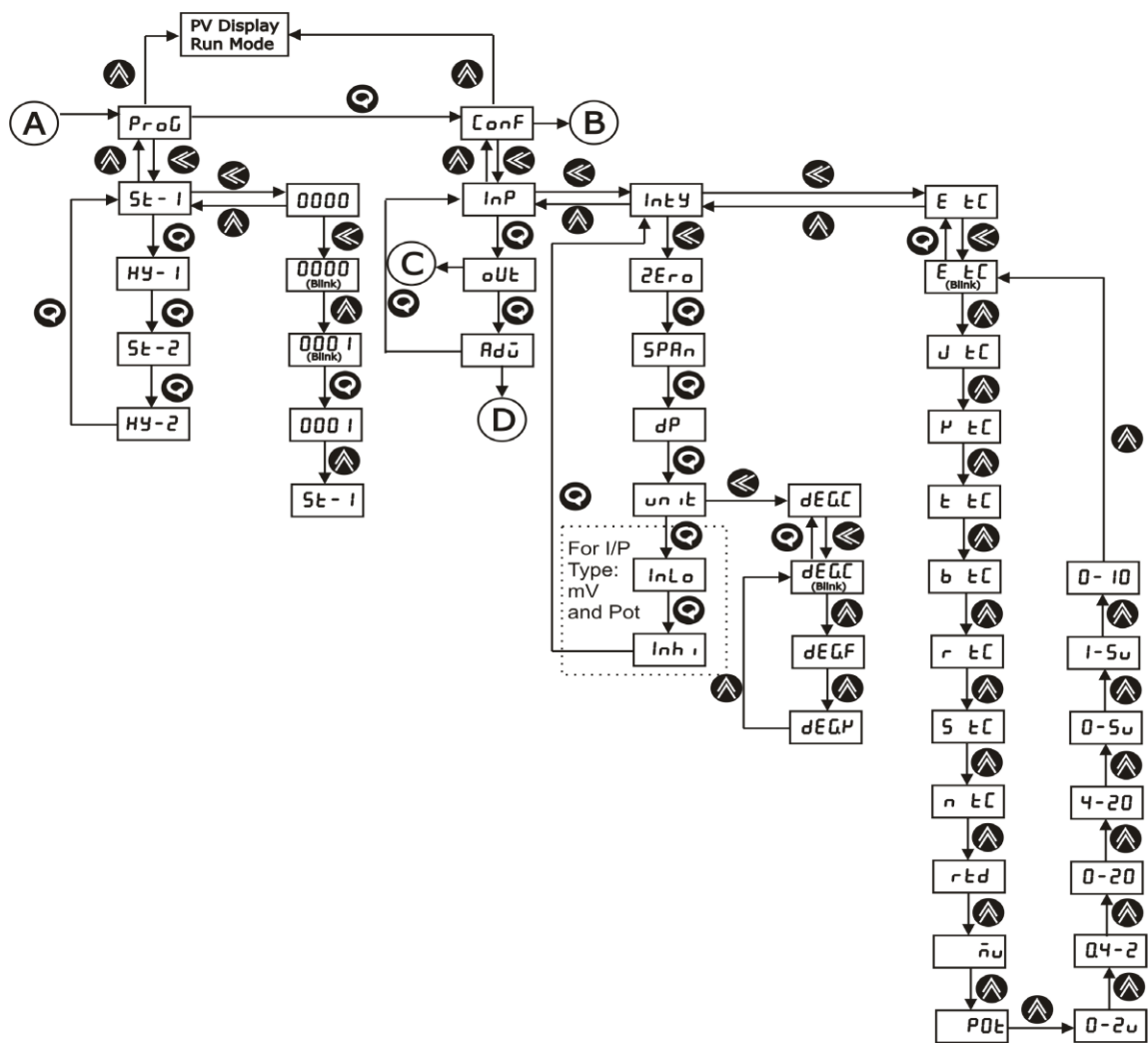
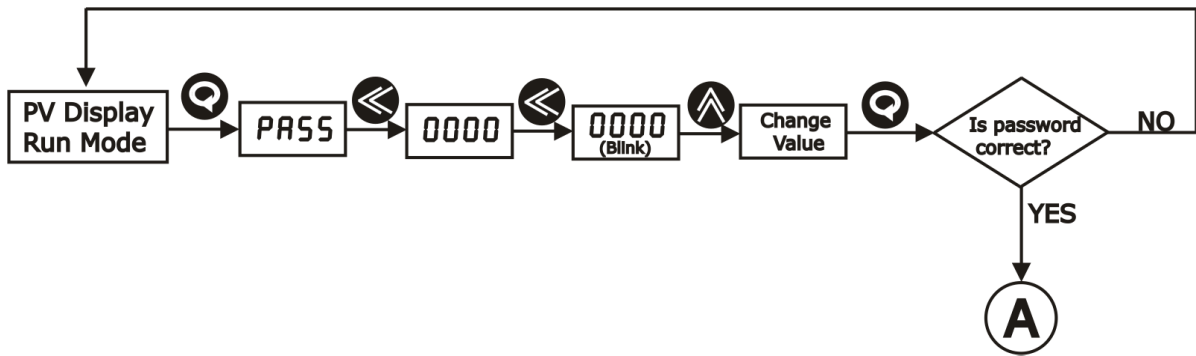

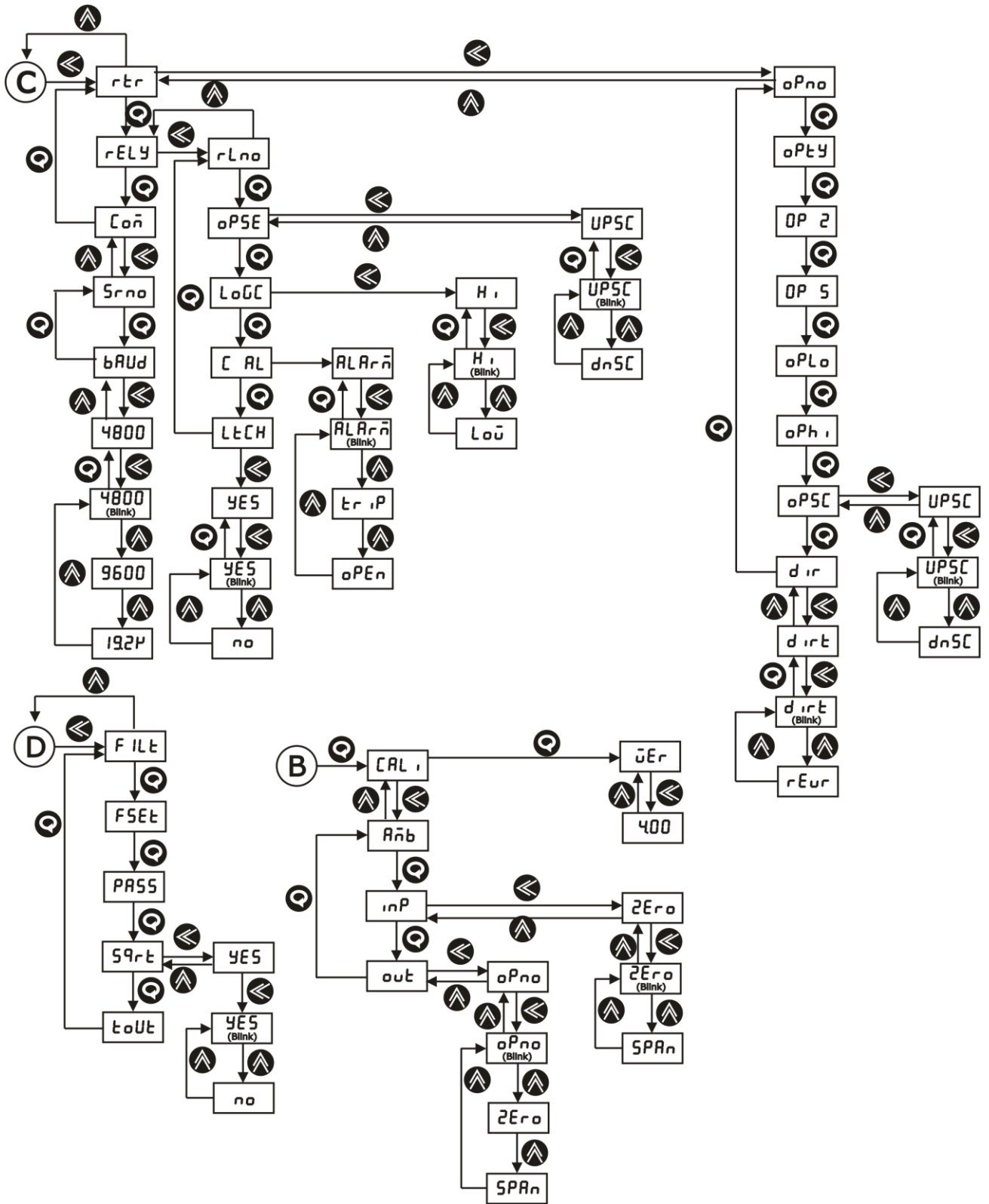

10. Calibration Procedure

Calibration for the unit is to be carried out by an experienced engineer only. Reference used for the calibration should be of high accuracy (0.1 % better) and good stability.

After Giving correct Password Press the Enter Key to enter into the menu levels (Scroll along using the Enter Key itself. From it select "CAL" using the SELECT Key). Here we have 3 options amb, INP, and OUT. Scroll along using the Enter Key and select the required option using the SELECT Key.

10.1 Ambient Calibration:

Once you enter the ambient calibration option the ambient temperature sensed by the device is shown. Now to calibrate it press the Select Key that blinks the digits one by one on each press, use the Increment Key to change the value from 0-9.

Adjust the values as required and press the Enter Key to save the value. Exit from the menu levels using the Inc/Esc Key. Now we have both Input and output calibration.

10.2 Input Calibration:

Here calibration is done only after entering zero and span value sequentially. For this we require a source with good stability and resolution.

Any of the inputs can be calibrated at any point within the entered range. The Inputs are divided into seven groups. Calibrating any of the inputs of a group will calibrate all the other inputs of the same group.

The groups are:

Group0: ETC, JTC, KTC, TTC, NTC.

Group1: BTC, RTC, STC.

Group2: RTD.

Group3: 0-5V, 1-5V.

Group4: 0-2V, 0.4-2V.

Group5: 0-20mA, 4-20mA.

Group6:mV (-10 to 500mV)input range : -10 to 25mV , -10 to 100mV, -10 to 500mV

Group7:Pot (0 to 2000 ohms) input range : 0 to 100 ohms, 0 to 600 ohms, 0 to 2000 ohms

Now select the INP from the menu feed the Zero input value for zero calibration and enter the Zero calibration option using the Select Key. Now change the values as required using the select and Inc Key. Save the value using the Enter Key and Exit one level back using the Inc/Esc Key.

Scroll to the Span calibration using the Enter key, Press Select Key to enter into the span calibration. Feed the span input for calibration and change the values as required and press Enter to perform calibration, Here it show a Wait Message until it completes the calibration Procedure. It automatically saves and applies the calibration parameters now. Exit the menu level using the Inc/Esc Key.

10.3 Output Calibration

Calibration is done only after entering both zero and span values sequentially for separate channels. For this we require a DMM of 6 1/2 Digits or more resolution. Input is not required while retransmission output calibration.

Calibration of current or voltage (that depends on provided factory setting) is done in described manner. In menu, first select the channel that has to be calibrated, monitor the output of that corresponding channel using DMM (Digital Multi meter). The voltage /current terminals are common and its selection is provided in factory setting. To calibrate the output, enter the zero option and correct the value you see on the display with the value you see in the DMM. Do the same for the Span too. Now select channel 2 and monitor the output of second channel and repeat the same steps as performed for the first channel output.

It's recommended to calibrate 0-20mA for current type output or 0-10V for voltage type retransmission output, which again depends on provided factory setting.

11. Modbus Detail:

The table show Analog data to be transmitted and its sequence.

11.1 Configuration parameter Read – write.

Sr. no	Analog Parameters	Absolute Address	Type of Access	Parameter Type	Values Applicable
1.	Set point for relay1	40001	Read/write	Int	
2.	Hysteresis for relay1	40002	Read/write	Int	0 - 100
3.	Set point for relay2	40003	Read/write	Int	
4.	Hysteresis for relay2	40004	Read/write	Int	0 - 100
5.	I/P type	40005	Read/write	Int	1 To 18
6.	I/P zero	40006	Read/write	Int	As per Input Range
7.	I/P span	40007	Read/write	Int	As per Input Range
8.	Decimal point	40008	Read/write	Int	0 - 3
9.	Engineering Units	40009	Read/write	Int	1 To 3
10.	I/P Lo (For I/P type: mV, Pot)	40010	Read/write	Int	-10 to 500
11.	I/P Hi (For I/P type: mV, Pot)	40011	Read/write	Int	0 to 2000
12.	O/P type1	40012	Read/write	Int	1 To 5
13.	O/P Z (% of O/P Zero) of O/P 1 for scaling	40013	Read/write	Int	0-300
14.	O/P S (% of O/P Span) of O/P 1 for scaling	40014	Read/write	Int	700-1000
15.	O/P Lo (% of O/P Zero range) for O/P1	40015	Read/write	Int	0-250
16.	O/P High (% of O/P Span range) for O/P1	40016	Read/write	Int	750-1000
17.	Open sensor for O/P1	40017	Read/write	Int	1 To 2
18.	Direction for O/P1	40018	Read/write	Int	3 To 4
19.	O/P type2	40019	Read/write	Int	1 To 5
20.	O/P Z (% of O/P Zero) of O/P 2 for scaling	40020	Read/write	Int	0-300
21.	O/P S (% of O/P Span) of O/P 2 for scaling	40021	Read/write	Int	700-1000
22.	O/P Lo (% of O/P Zero range) for O/P2	40022	Read/write	Int	0-250
23.	O/P High (% of O/P Span range) for O/P2	40023	Read/write	Int	750-1000
24.	Open sensor for O/P2	40024	Read/write	Int	1 To 2
25.	Direction for O/P2	40025	Read/write	Int	3 To 4
26.	Open sensor for relay1	40026	Read/write	Int	1 To 2
27.	Relay control logic for relay1	40027	Read/write	Int	1 To 2
28.	Configure alarm for relay1.	40028	Read/write	Int	1 To 3
29.	Latch for relay1	40029	Read/write	Int	1 To 2
30.	Open sensor for relay2	40030	Read/write	Int	1 To 2
31.	Relay control logic for relay2	40031	Read/write	Int	1 To 2
32.	Configure alarm for relay2	40032	Read/write	Int	1 To 3
33.	Latch for relay2	40033	Read/write	Int	1 To 2
34.	Slave ID	40034	Read/write	Int	1 - 247
35.	Baud rate	40035	Read/write	Int	1 To 3
36.	Digital filter	40036	Read/write	Int	0 - 60
37.	Password	40037	Read/write	Int	-1999 - 9999
38.	Square root	40038	Read/write	Int	1 - 2
39.	Time out from the menu	40039	Read/write	Int	10 - 300

Note: The values for above configuration parameter are as follows:

a) I/P Type:

- E - 1
- J - 2
- K - 3
- T - 4
- B - 5
- R - 6
- S - 7
- N - 8
- PT100, 3W (RTD) - 9
- mV (-10–500 mV) - 10
- Pot (0-2000 ohms) - 11
- 0-2 V - 12
- 0.4-2 V - 13
- 0-20 mA - 14
- 4-20 mA - 15
- 0-5 V - 16
- 1-5 V - 17
- 0-10 V - 18

b) Engineering Units:

- Celsius - 1
- Fahrenheit - 2
- Kelvin - 3

c) O/P type:

- 0-20 mA - 1
- 4-20 mA - 2
- 0-5 V - 3
- 1-5 V - 4
- 0-10 V - 5

d) Open sensor for O/P:

- Up - 1
- Down - 2

e) Direction for O/P:

- Direct - 3
- Reverse - 4

f) Open sensor for relay:

- Up - 1
- Down - 2

g) Relay control logic:

- Hi - 1
- Low - 2

h) Configure alarm for relay:

- Alarm - 1
- Trip - 2
- Open - 3

i) Latch for relay:

- Yes - 1
- No - 2

j) Baud rate:

- 4800 - 1
- 9600 - 2
- 19200 - 3

k) Square root:

- No - 1
- Yes - 2

11.2 Configuration parameter Read:

Sr. no	Analog Parameters	Absolute Address	Type of Access	Parameter Type
1	Process value	30001	Read	Int
2	Ambient	30002	Read	Int

Note:

- a) Display on UT-94 will show “**over**” when process value is higher than 5 % of individual span, at that time UT-94 will send ‘32766’ to PC. (Not applicable for linear inputs)
- b) Same way when process value is lower than 5 % of individual zero UT-94 will show “**under**” on its display but it will send ‘32765’ to PC. (Not applicable for linear inputs)
- c) If UT-94 process value is out of limit for particular I/P type then UT-94 will show “Open” on display but it will send ‘32767’ to PC
- d) The serial no of UT-94 Indicators must be within 001 to 247.
- e) Before starting the communication, match the Baud rate and Sr. no. of Master and Slave devices.
- f) When process value is lower than minimum value of input range, UT-94 will show value up to 5% of input range for input type 1-5V,4-20mA,0.4-2V .
- g) When process value is greater than maximum value of input range, UT-94 will show value up to 5% of input range for input type 1-5V,4-20mA,0.4-2V, 0-5V,0-20mA,0-10V,0-2V.
- h) When process value is lower than minimum value of input range, UT-94 will show zero value (lower range) for input type 0-5V,0-20mA,0-10V,0-2V.

12. Specifications

12.1 Input Specification:

No. of Input	: One
Input Type	: As per Table-1
Display Range	: Table-1
Resolution	: Table-1
Accuracy	: E, J, K, T, N, Pt100, mV, V, mA, Pot: 0.1 % of FS B, R, S: ±0.25 % of FS
ADC Resolution	: 17 bits
Linearization Method	: Through Software, using 9th order Co-efficient
Display Resolution	: 0.1°C / 1 Count
Response Time	: I/P to O/P : <200 mSec
CJC Error	: ±2.0 °C Max
Sensor Burnout current	: 0.5uA
RTD excitation current	: 1mA (Approx.)
NMRR	: > 50 dB
CMRR	: > 120 dB
Temp-co	: I/P to Display:100 ppm Display to O/P: 150 ppm
Input Impedance for V Input	: > 1MΩ
Input Burden for mA Input	: ≤ 3V
Max Voltage	: 20VDC
Cold Junction Compensation	: By software

12.1.1 Input range table:

Input	Range	Resolution
E TC	-200 to 1000 °C	# 0.1 °C
J TC	-200 to 1200 °C	# 0.1 °C
K TC	-200 to 1370 °C	# 0.1 °C
T TC	-200 to 400 °C	0.1 °C
B TC	450 to 1820 °C	1 °C
R TC	0 to 1750 °C	1 °C
S TC	0 to 1750 °C	1 °C
N TC	-200 to 1300 °C	# 0.1 °C
RTD Pt100	-200 TO 850 °C	0.1 °C
mV(-10 to 500 mV)	-1999 to 9999 Counts	1 Count
Pot(0 to 2000 ohms)	-1999 to 9999 Counts	1 Count
0 to 2 V	-1999 to 9999 Counts	1 Count
0.4 to 2 V	-1999 to 9999 Counts	1 Count
0 to 20 mA	-1999 to 9999 Counts	1 Count
4 to 20 mA	-1999 to 9999 Counts	1 Count
0 to 5 V	-1999 to 9999 Counts	1 Count
1 to 5 V	-1999 to 9999 Counts	1 Count
0 to 10 V	-1999 to 9999 Counts	1 Count

Note: # Resolution 1°C after 999.9 °C.

12.2 Display & Keys:

Process Value	: 0.3" Four-digit Seven segment Red LED
Status Indication	: Red LED's Two for Relays, Two for Communication
Display Scaling	: -1999 to 9999
Keys	: 3 keys (ENT, SEL & ESC) for configuration, calibration and Operation

12.3 Output:

Relays (Optional)	: 2 Nos.
Type	: Single Change over (C, NO, NC)
Rating	: 2A @ 230VAC / 30VDC

12.4 Retransmission Output

Number of output	: 2 (O/P-2 is Optional)
Output Signal	: 4-20mA/ 0-20mA/1-5VDC/ 0-5VDC/0-10V DC (At a time either voltage or Current o/p will be provided for Each channel, that will be factory set)
Load resistance	
For Current o/p	: < 750Ω
For Voltage o/p	: > 4KΩ
Output accuracy	: ±0.25 % of Full Scale
Over Range O/P	: 5 % above F.S. (Not applicable for Voltage Inputs)
Transmitter Power Supply	: 24VDC (±1V) @30mA, with Short circuit Protection

12.5 Communication:

Interface	: RS485 (2 Wire)
Protocol	: Modbus-RTU
Communication Method	: 2 wire half duplex
Data Frame	: N, 8, 1
Baud rate	: 4800, 9600, 19200 bps
Address Range	: 001 to 247
Distance Of Communication	: 1200 meter (Twisted pair cable as per EIA 485 standard)
Maximum Slaves	: 32 without repeaters

12.6 Power Supply

Standard	: 85-265VAC/ 100-300VDC
Optional	: 18-36VDC
Power consumption	: <10 VA

12.7 Isolation (Withstanding voltage):

* Three port isolation i.e. between input/output/power supply (1500VAC for 1 minute)

12.8 Insulation resistance:

2000M Ω or at 500 V DC between input, output and power supply.

12.9 Physical:

Size	: 55(W) x 75(H) x 110(D) mm
Mounting	: Din Rail
Terminal Cable Size	: 2.5mm ²
Weight	: < 250 gm

12.10 Environmental:

Operating temperature	: 0-55 °C
Storage temperature	: 0-80 °C
Humidity	: 20-95 % RH non-condensing

12.11 Advance Option:

Digital Filter	: 0-60 Second
Password Setting	: Available
Square Root	: Available for linear inputs only
Output Direction	: Direct / Reverse (programmable)
Output Signal Limit	: Available (low and high)
Engineering Unit	: °C, °F, °K (for T/C and RTD inputs)
Decimal Point	: Programmable for linear inputs
Scaling for Retransmission output	: Min limit: 0-30 % for Output Zero, Max limit: 70-100 % for Output Span

13. Relay Logic:

Without acknowledge key pressed									
CONDITION	ALARM LATCH/TRIP	RELAY/LED	NORMAL	ABNORMAL	UP	DOWN	ACK IN ABNORMAL CONDITION	NORMAL	ACK IN NORMAL CONDITION
HIGH	ALARM LED LATCH YES	LED	OFF	FLASH	FLASH	OFF	-	STEADY	OFF
		RELAY	OFF	ON	ON	OFF	-	OFF	OFF
	ALARM LED LATCH NO	LED	OFF	FLASH	FLASH	OFF	-	OFF	OFF
		RELAY	OFF	ON	ON	OFF	-	OFF	OFF
	TRIP	LED	OFF	FLASH	OFF	OFF	-	STEADY	OFF
		RELAY	OFF	ON	OFF	OFF	-	ON	OFF
LOW	ALARM LED LATCH YES	LED	OFF	FLASH	OFF	FLASH	-	STEADY	OFF
		RELAY	OFF	ON	OFF	ON	-	OFF	OFF
	ALARM LED LATCH NO	LED	OFF	FLASH	OFF	FLASH	-	OFF	OFF
		RELAY	OFF	ON	OFF	ON	-	OFF	OFF
	TRIP	LED	OFF	FLASH	OFF	OFF	-	STEADY	OFF
		RELAY	OFF	ON	OFF	OFF	-	ON	OFF
With acknowledge key pressed									
CONDITION	ALARM LATCH/TRIP	RELAY/LED	NORMAL	ABNORMAL	UP	DOWN	ACK IN ABNORMAL CONDITION	NORMAL	ACK IN NORMAL CONDITION
HIGH	ALARM LED LATCH YES	LED	OFF	FLASH	FLASH	OFF	STEADY	STEADY	OFF
		RELAY	OFF	ON	ON	OFF	OFF	OFF	OFF
	ALARM LED LATCH NO	LED	OFF	FLASH	FLASH	OFF	STEADY	OFF	OFF
		RELAY	OFF	ON	ON	OFF	OFF	OFF	OFF
	TRIP	LED	OFF	FLASH	OFF	OFF	STEADY	STEADY	OFF
		RELAY	OFF	ON	OFF	OFF	ON	ON	OFF
LOW	ALARM LED LATCH YES	LED	OFF	FLASH	OFF	FLASH	STEADY	STEADY	OFF
		RELAY	OFF	ON	OFF	ON	OFF	OFF	OFF
	ALARM LED LATCH NO	LED	OFF	FLASH	OFF	FLASH	STEADY	OFF	OFF
		RELAY	OFF	ON	OFF	ON	OFF	OFF	OFF
	TRIP	LED	OFF	FLASH	OFF	OFF	STEADY	STEADY	OFF
		RELAY	OFF	ON	OFF	OFF	ON	ON	OFF

Table 1

Note: If open type relay is selected then relay and LED will be ON when OPEN condition, while it will remain off if not in OPEN condition.

14. Appendix:

14.1 Internal Jumper Setting For Retransmission Output

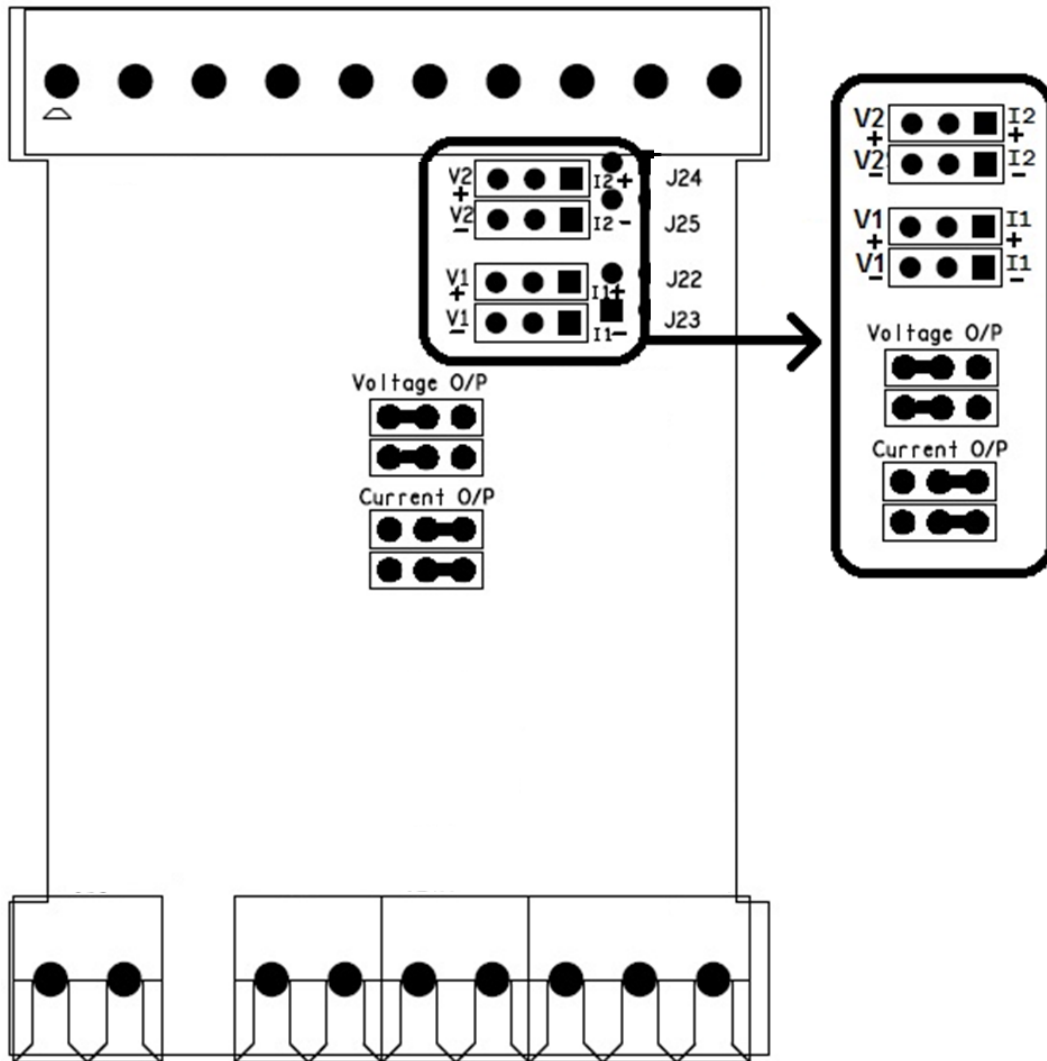

For retransmission voltage or current output, connect jumper as shown above on back plate PCB.



Static discharge will cause damage to equipment. Always ground yourself with wrist grounding strap when handling electronics to prevent static dis-charge.

14.2 Troubleshooting:

For primary troubleshooting of instrument use following procedure:

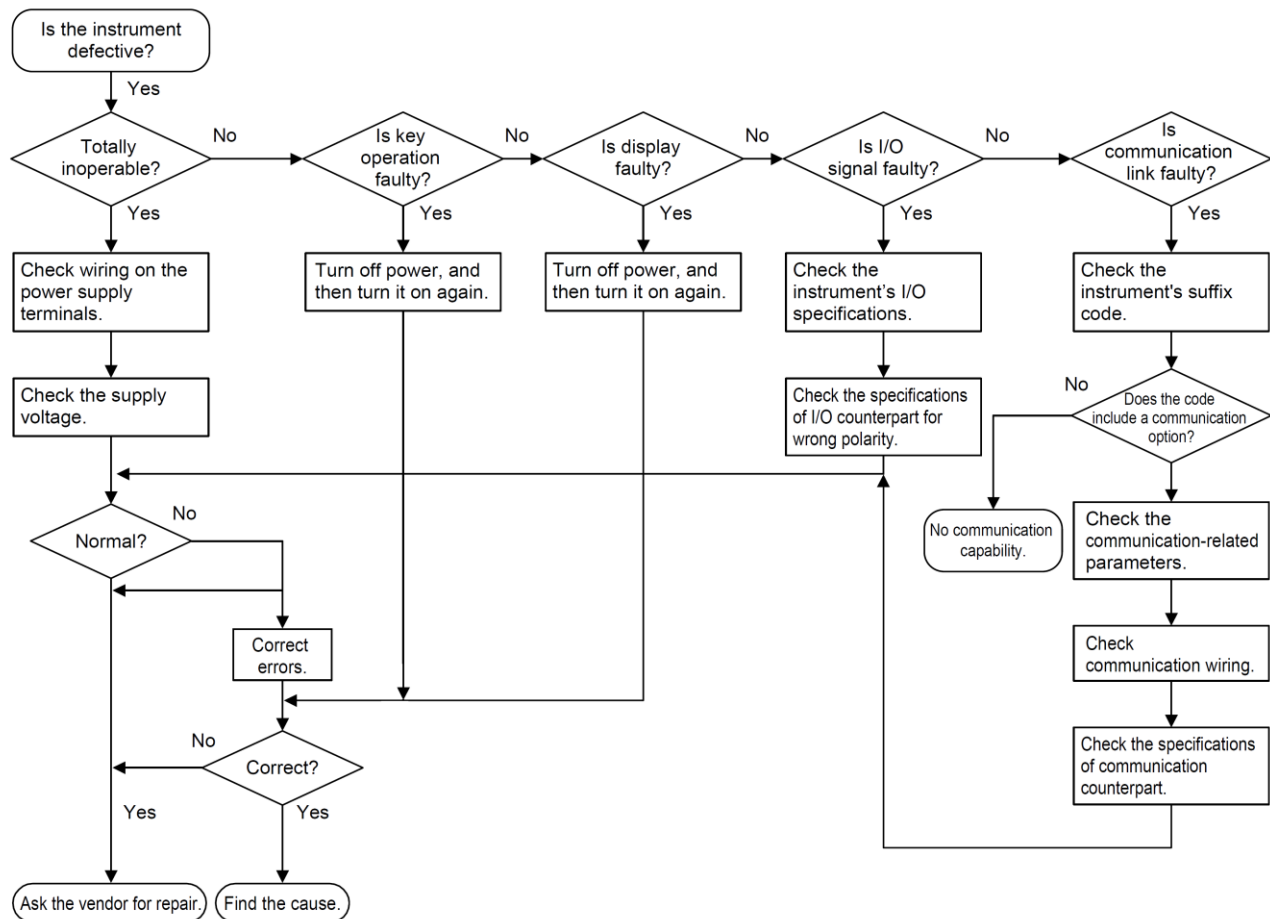

14.3 Load connection

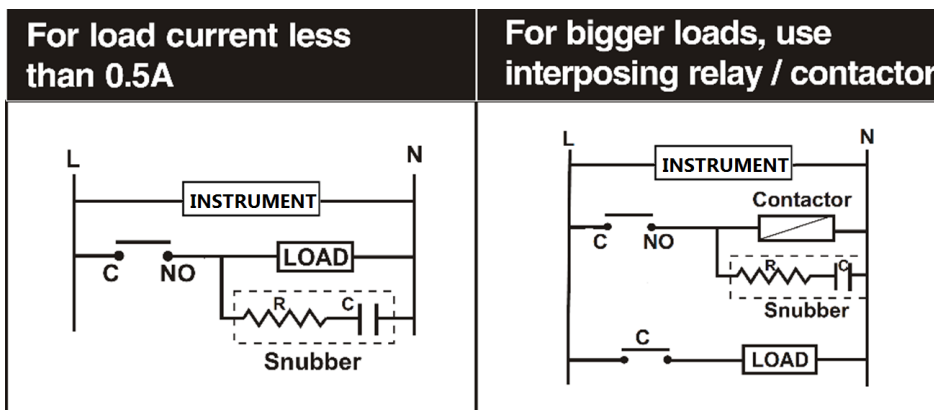

Electrical precautions during use

Electrical noise generated by switching of inductive loads can create momentary disruption, erratic display, latch up, data loss or permanent damage to the instrument. Use of snubber circuits across loads as shown above, is recommended.