



Isolator's & Transmitter's



What is Signal Isolator

A signal isolator or signal converter is a signal conditioning device used to interface process signals with other control / monitoring (PLC / DCS / Recorder / Indicator / HMI etc) devices. It Isolates / Converts / Splits / Amplifies the incoming signal to the output devices. Signal isolators ensure a stable and accurate signal output by offering superior resistance to electro-magnetic interference.

(A Barrier is generally used in hazardous areas . It reduces loop current below to safe level where it can not cause any spark. An Isolator is generally used to interface signals having different common mode voltages)

Why Isolator is Needed

Signal Isolators are required for the electrical isolation , essential for safety , to eliminate erratic measurements caused by ground loops . It splits one signals to many to be fed to different systems, to amplify field signals , step down high voltage signals to a safer level , protection against EMI noises & cross talk elimination. In a nutshell , signal Isolator is required to break the galvanic path between the two grounds . It protects the system from surge / high transient voltage generated from switching inductive loads, lighting etc.

Risk of Non-Isolated Signals

- Non-Isolated signals can damage the Costly DCS/PLC IO card
- It also causes the false measurement due to ground loops.
- Lighting/surges generated by switching loads may travel from field side to control systems and possibilities are it may damage the control systems.
- There is risk of cross talk between two field signals if they are non-isolated.
- Non-Isolated field signals are EMI susceptible that causes error in measurements

A ground loop forms when the voltages at two ground points in a loop are at different potentials

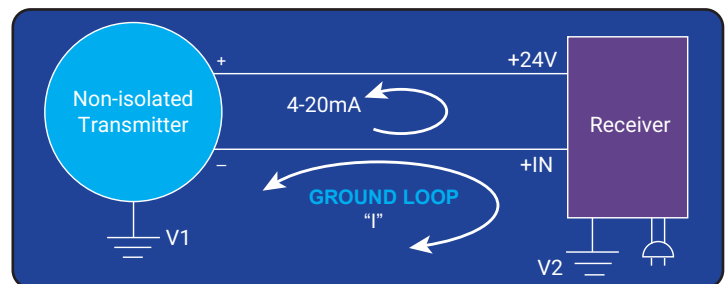

A signal isolator “breaks” the galvanic path between two grounds.

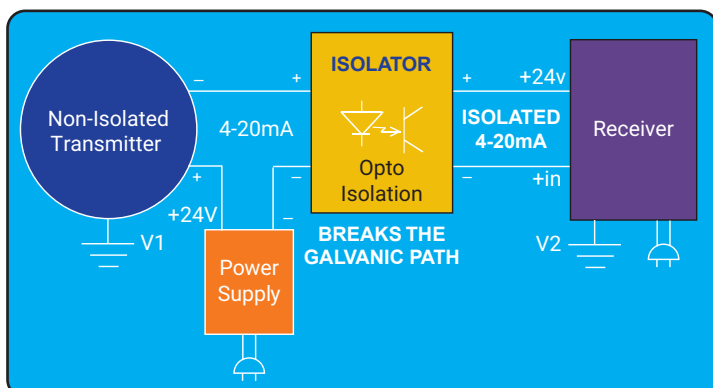

Where all Isolator is Required

- **VFD Panels:** Protect the DCS/PLC IO modules from extraneous high voltage noises generated by VFDs
- **Automation Panels:** Interface and protects the DCS and PLC IO modules from fields signals
- **Instrumentation Panels:** Signal conversion, amplification and signal splitting application
- To convert 2-wire signals into 4-wire in PLC panels
- Signal isolation and conversion in MCC/PCC panels



9000C

(Slim Signal Isolator)
Single (SOP) & Dual (DOP) Output
Aux (AP) & Loop (LP) Powered

9000Ex-1/9000Ex-2

(One/ Two Channel Intrinsically
Safe Transmitter Power Supply/
Isolated Barrier/ Signal Isolator)

9000E

(One/ Two Channel
Signal Isolator)

9000L

(Signal Isolator
Single/Dual Output)

9000LE

(One/ Two Channel
Signal Isolator)

9000U+

(Signal Isolator
Single/Dual Output)

Technical Specification

Models	9000C-S	9000C-M	9000C-H	9000C-L	9000U+	9000U+M	9000L	9000L-M	9000LE	9000E	9000Ex-1 9000Ex-2
SOP (Single Input, Single Output)	✓	✓	✓	✓	✓	✓	✓	✓	✓	✓	✓
DOP (Single Input, Dual Output)	✓	✓	✓	✗	✓	✓	✓	✓	✓	✓	✓
Dual Channel	✗	✗	✗	✗	✗	✗	✗	✗	✓	✓	✓
HART Pass	✗	✗	✓	✗	✗	✗	✗	✗	✓	✓	✓
Loop Power	✗	✗	✗	✓	✗	✗	✗	✗	✗	✗	✗
Fixed Input /Ouput (mA/V)	✓	✗	✓	✓	✓	✗	✓	✓	✓	✓	✓
Switch Selectable Input/Ouput (mA/V)	✗	✓	✗	✗	✗	✓	✗	✗	✗	✗	✗
Drift/Year (<0.1% of FS)	✓	✓	✓	✓	✓	✓	✓	✓	✓	✓	✓
Power Supply (20 - 265V DC/AC)	✓	✓	✓	✓	✓	✓	✓	✓	✗	✗	✗
Power Supply (20 - 35V DC)	✗	✗	✗	✗	✗	✗	✗	✗	✓	✓	✓
Transmitter Power Supply	✓	✓	✓	✗	✓	✓	✗	✗	✓	✓	✓
3-Port Isolation	✓	✓	✓	✓	✓	✓	✓	✓	✓	✓	✓
CE Mark	✓	✓	✗	✗	✗	✗	✗	✗	✗	✗	✗
Intrinsically Safe	✗	✗	✗	✗	✗	✗	✗	✗	✗	✗	✓
Temperature Coefficient (≤100 ppm/°C)	✓	✓	✓	✓	✓	✓	✓	✓	✓	✓	✓
CMRR (>100dB)	✓	✓	✓	✓	✓	✓	✓	✓	✓	✓	✓
NMRR (>70dB)	✓	✓	✓	✓	✓	✓	✓	✓	✓	✓	✓
Response Time	≤50mSec.								≤50 μSec.		
Accuracy	± 0.1% of FS						± 0.25% of FS		± 0.1% of FS		
Operating Temperature	0 to 55 °C						-20 to 60 °C				
Width	12.5mm/17.5mm		17.5mm	12.5mm	35 mm				17.6 mm		

9000LE- Single / Dual Channel Signal Isolator

Features

- Compact DIN-Rail mount design of 35mm with one or two-channel option
- Highly stable against temperature variation, Drift ≤ 50 PPM
- 2 wire & 4 wire transmitter configuration option available
- High response time $\leq 50\mu\text{s}$
- BEST IN CLASS ACCURACY, $\leq 0.1\%$ of full span
- HART pass-through available with 2- wire transmitter supply configuration
- Low power consumption, ≤ 1.3 W per channel with TPS, ≤ 0.7 W per channel without TPS & low cost per channel
- 2KV three-port Isolation



9000LE

9000Ex-1/9000Ex-2 - Signal Isolator

Features

- Intrinsically safe Associated Device
- Compact DIN-Rail mount design of 17.6mm width
- 2W transmitter input with HART Pass
- High KV 3 port isolation of each channel
- High Accuracy, low drift, low temperature effect
- Input and Output well protected
- Fast response suits all applications
- Low power dissipation



PESO Certified



9000Ex-1/9000Ex-2

[Ex ia Ga] IIC

PESO Approval No.: A/P/HQ/GA/104/5522

Ex Standards Complied: IS/IEC 60079-0:2017
IS/IEC 60079-11:2011

Connection Diagram

9000Ex-1

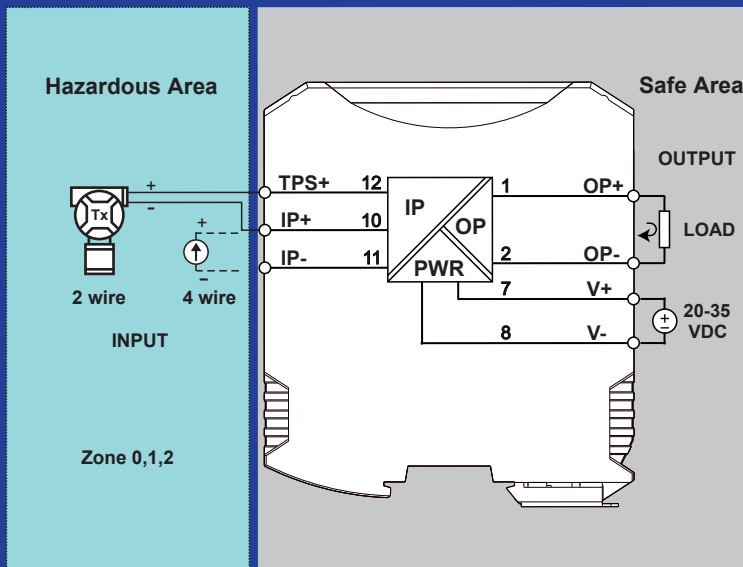

9000Ex-2

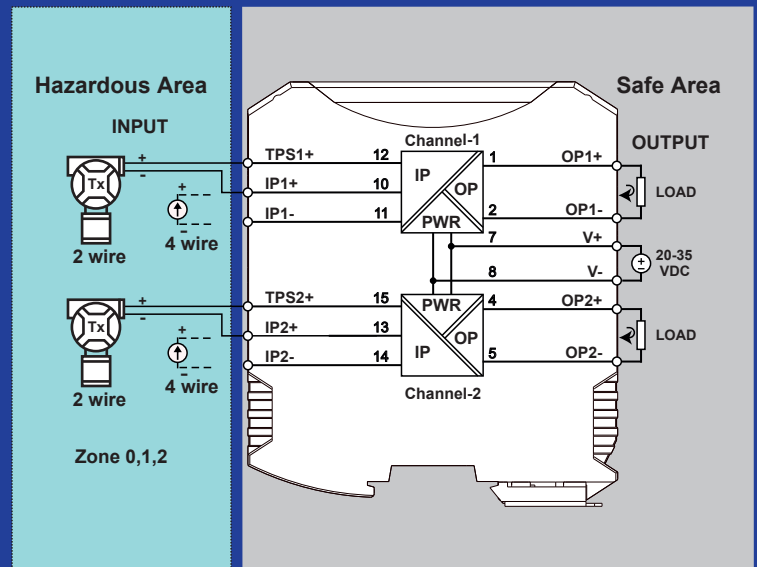

9000E- Signal Isolator

Features

- Compact DIN-Rail mount design of 17.6mm width
- 2W transmitter input with HART Pass
- High KV 3 port isolation
- High Accuracy, low drift & low temperature effect
- Input and Output well protected
- Fast response suits all applications
- High CMRR and NMRR
- Slim design for one/two channels



9000E

Process Industries Application

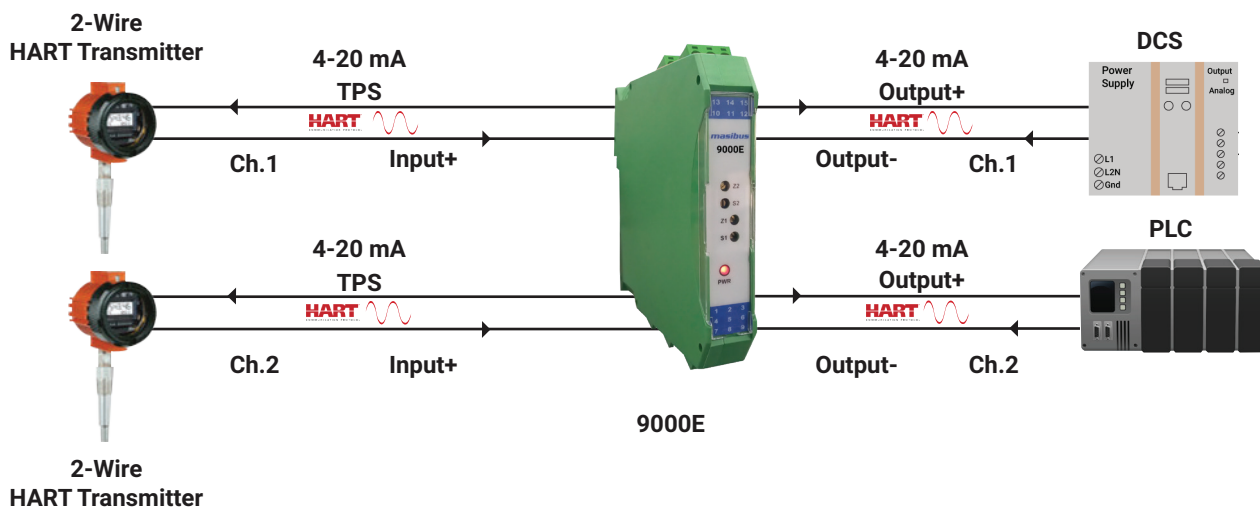

VFD Application

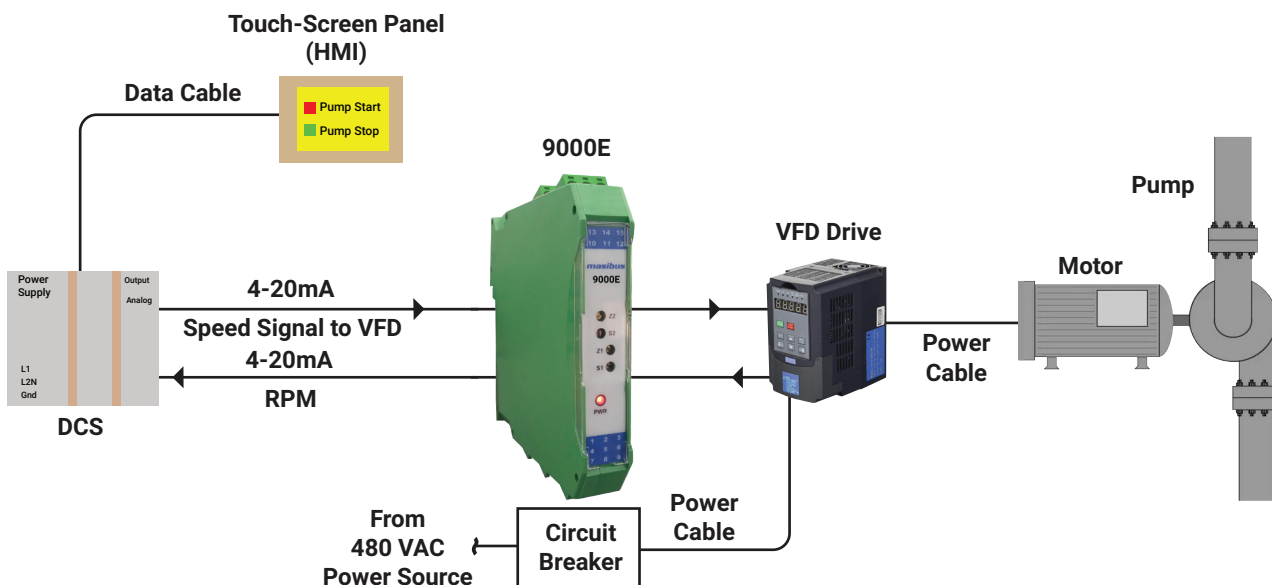



9000C Signal Isolator

Features

- Available in Aux Powered (AP) and Loop Powered (LP) options
- Slim DIN-Rail mount design of 12.5mm for single output and 17.5mm for dual output
- Rugged & accurate 4 wire and 2 wire Isolator
- Up to 2 outputs with short circuit protection
- CE certified model option
- HART pass through model



9000U+ Signal Isolator

Features

- Rugged & accurate 4 wire isolator
- Switch option for 0/4-20mA, 0/1-5V and 0-10V I/O selection
- Extended universal power supply range: 20V to 265V DC or AC
- 2.0KVAC three port isolation
- Wide zero & span adjustment limits
- Front calibration facility via multiturn trimpot

9000L- Signal Isolator



Features

- Compact DIN-Rail mount design of 35mm for single and dual output
- 1.5 KV AC three port isolation
- Up to 2 outputs with short circuit protection
- High CMRR and NMRR
- High output load driving capability

Best Fit for VFD Application

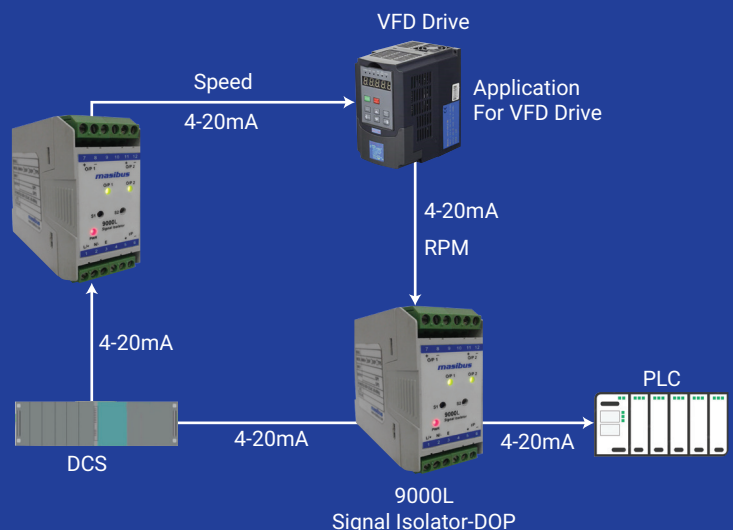

Cell Voltage Monitoring with Voltage Deviation Transducer for Electrolyzer

Caustic soda and hydrochloric acid produced in electrolyzer plants, are fundamental materials used in varieties of industries i.e. chemicals, pharmaceuticals, petrol-chemicals, pulp & papers, etc. Proper control of the process brings you stabilized quality of products with the vast operational profit.

Caustic soda (NaOH) and Chlorine (Cl₂) are generated by the electrolysis of Salt (NaCl). Electrolyzer is used to produce these fundamental materials.

The latest technology of this electrolysis system called "Electrolyzer" is used in Ion exchange membranes.

Ion exchange Membranes in electrolyzer is called "cell". An electrolysis bath is consisted of many cells. Cells are connected by series connection to each other. A Cell has life time, so it should be maintained periodically by monitoring the Cell Voltage.

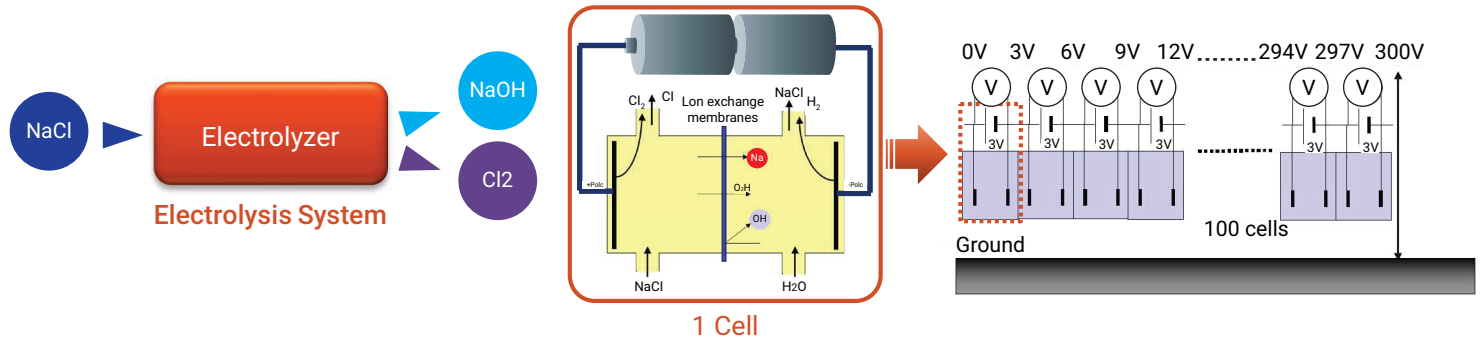

9000U-HDE- Voltage Deviation Transducer

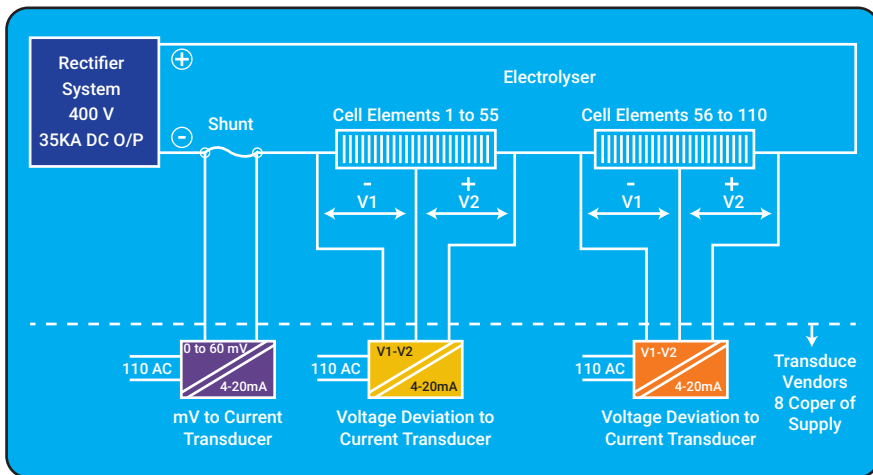

9000U-HDE

9000C Application: Instrumentation Panel

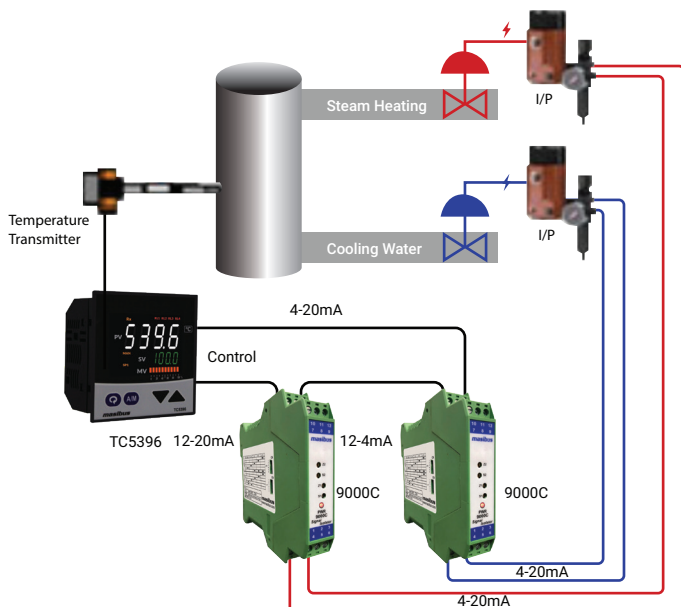

9000C PLC/DCS Panel with HART Application

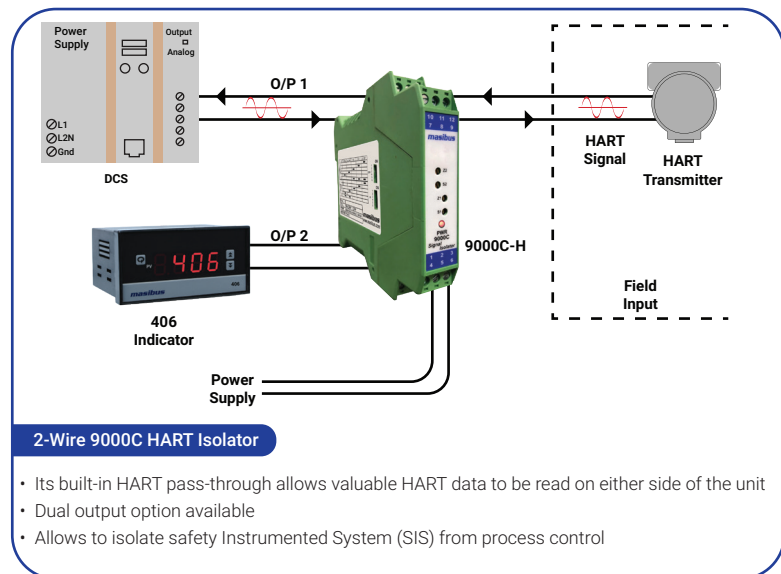

2-Wire 9000C HART Isolator

- Its built-in HART pass-through allows valuable HART data to be read on either side of the unit
- Dual output option available
- Allows to isolate safety Instrumented System (SIS) from process control

What is Transmitter ?

Transmitter is a device which converts the signal produced by a sensor into a standard instrumentation signal representing a process variable being measured and controlled. The standard electrical signals are 4 to 20 mA or 1 to 5 volts. Transmitters are highly used in the process industries.

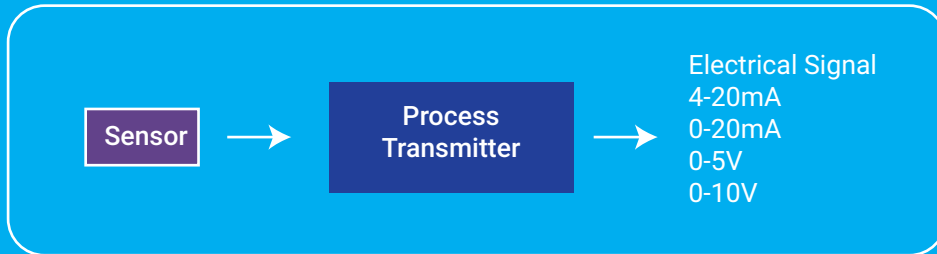

Why are Transmitters Required ?

- Signal Conversion of sensor raw signal into electrical signals
- Robust Signal Transmission by use of signal conditioning, linearization & isolation
- Minimize maintenance cost, simplify the engineering design and cost optimization
 - By eliminating longer Sensor cables
 - Use standard 4-20mA I/P Card at DAQ/DCS
- Protection against EM and RF noises
- Suppress the unwanted noise with the help of digital filter.

Sources of Signal Interference

- Capacitive Coupling
 - Shielding-cable spacing- Twisted pair
- Magnetic Coupling
 - Twisted pair-Cable spacing- Eliminate ground loops-shield grounding- Isolation
- Ground Loops
 - Correct shield grounding-Isolation
- Over-Voltage and Transients
 - Shielding-Isolation-Equipment selection- Cable spacing
- EMI/RFI
 - Shielding-Twisted pair -Equipment selection

Terminology

What is 2-Wire Transmitters (Loop Power Transmitters):

This configuration supplies power and 4-20mA signal over a two wire loop connection between the transmitter and the control panel. These two wires are used to power the transmitter and also to transmit the output signal.

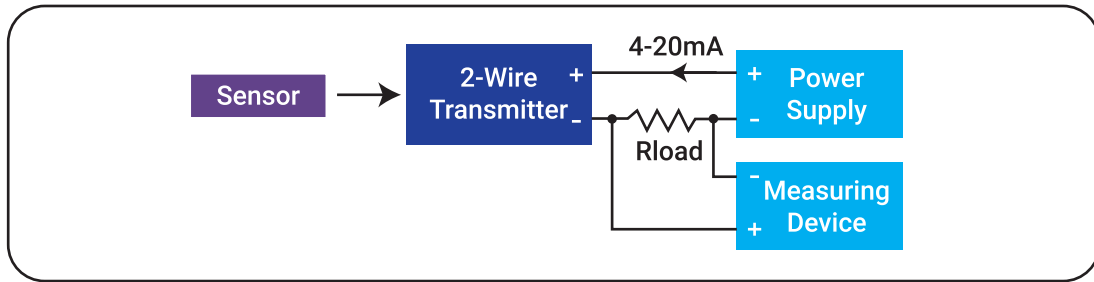

3-Wire Transmitters:

The 3-wire transmitter would transmit the data signal and the power with respect to the common ground. Three-wire transmitters are energized by the supply voltage in the transmitter. In this transmitter, the current loop can also be operated on a measuring instrument that has high input impedance.

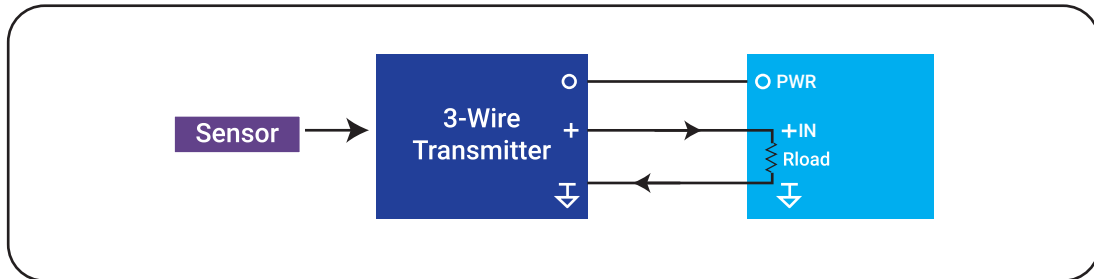

4-Wire Transmitters:

In 4-wire transmitter, two wires are used for the data signal and two wires for the power supply. 4 wire transmitters are powered by the external power supply at the transmitters. The 4-20mA signal flows through two separate cable cores between the transmitter and control panel.

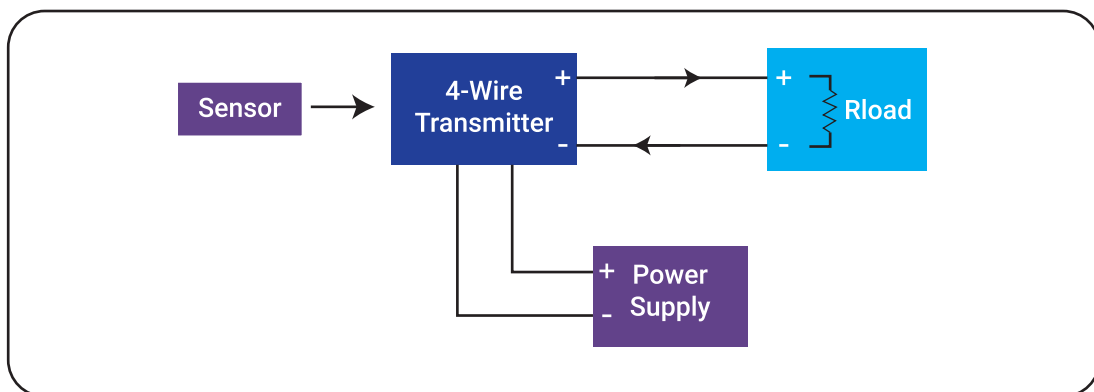

Critical Parameters of Temperature Transmitter

Isolation Level

Accuracy

Drift / Stability

Temperature Coefficient

Response Time

MTBF

Minimum Operating Voltage

Operating Temperature

Ingress Protection

Input Types & Ranges

Minimum span

RTD: Excitation Current, Lead Resistance

Thermocouple: Burn-out current

Configuration & Calibration

CMRR/NMRR



HT7S11S
Humidity and Temperature Transmitters



DPT7S10
Differential Pressure Transmitter



TPT-20
Tap Position Transmitter



UT-94
Universal Transmitter



SGT-18
Load Cell Transmitter

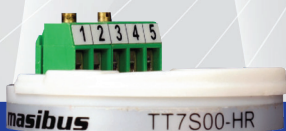

TT7S00-HR
2-Wire Transmitter



TT7S10-D
Strain Gauge Transmitter



TT7S10-XP
(Single Compartment)



TT7S10-XP
(Dual Compartment)

(Loop Powered Temperature Transmitter with Display)



TT7S10-H



TT7S10



TT7S11S

Isolated & Programmable Temperature Transmitters



DPT7S10

DPT7S10 Differential Pressure Transmitter

Features

- Wide loop supply voltage range from 10VDC to 36VDC
- Custom built LCD 4-digit display
- Configurable unit measurement in mmWC / Pa
- Available in compact and light weight design for easy and simple wall mount installation
- Configurable by front keypad (Available in device with display)



HT7S11S

HT7S11S Humidity and Temperature Transmitter

Features

- Wide loop supply voltage range from 10VDC to 36VDC
- Custom built LCD display
- Configurable temperature unit measurement in celsius/fahrenheit/kelvin
- Available in wall and duct mount
- Configurable by front keypad (Available in device with display)

RH/T Transmitter and DP Transmitter for Clean Room Application

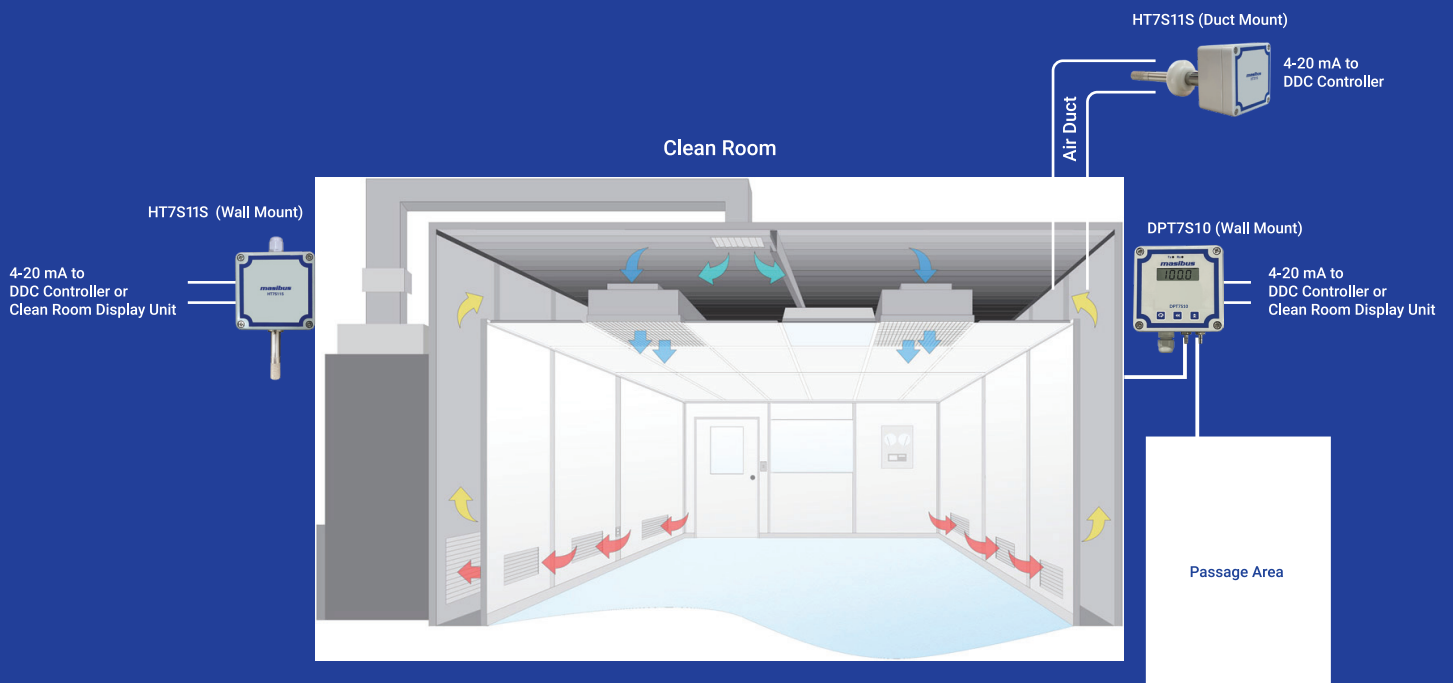

TT7S Isolated & Programmable Temperature Transmitters

Features

- Universal input (RTD, Thermocouple, Ohm, mV)
- Full three port isolation
- Linearized Output
- Highly accurate
- Fully Programmable for input type & range

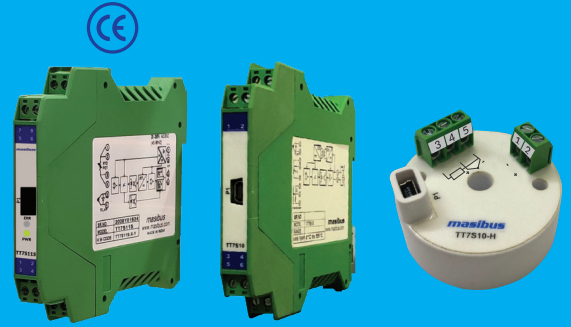

TT7S11S

TT7S10

TT7S10-H

TT7S00-HR 2-Wire Transmitter Pt-100 input

Features

- Multi-range design
- Output linear to temperature
- Analog linearized for 0.1% linearity
- Sized for DIN B heads and bigger
- Sensor break selection for upscale or downscale

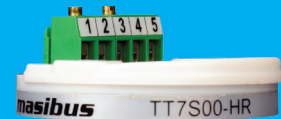

TT7S00-HR

TPT-20 Tap Position Transmitter

Features

- Micro controller based design
- Compact DIN-Rail mounting
- 4 digit red digital display for tap position
- Easy configuration using keys & display
- Programmable tap number upto 100



TPT-20



TT7S10-D



TT7S10-XP
(Single Compartment)



TT7S10-XP
(Dual Compartment)

TT7S10-D/TT7S10-XP Loop Powered Temperature Transmitter with Display

Features

- Universal input (RTD, Thermocouple, Ohm, mV)
- Available in below options
 - TT7S10-D: DIN-Rail mount with 0.3", 4 digit LED display
 - TT7S10-XP: Wall or 2" pipe mount Ex-proof transmitter with touchsense keys
- 0.56", 4 digit LED display in single compartment
- 0.39", 4 digit LED display in dual compartment
- 1.5 KV RMS isolation between input & output
- Linearized output
- Highly accurate
- Fully Programmable for input type & range
- User configurable digital filter
- Easy configuration using front keys and software



SGT-18

SGT-18 Load Cell Transmitter

Features

- Selectable load cell input ranges
- 5 digit 0.56" LED display
- Local cell excitation voltage selectable from 5 to 15V DC (Factory set)
- Tare adjustment through keypad/IO
- User selectable gross and net values for retransmission output
- RS-485 interface (Optional) for connecting PLC/DCS

Dynamic Weighing Application

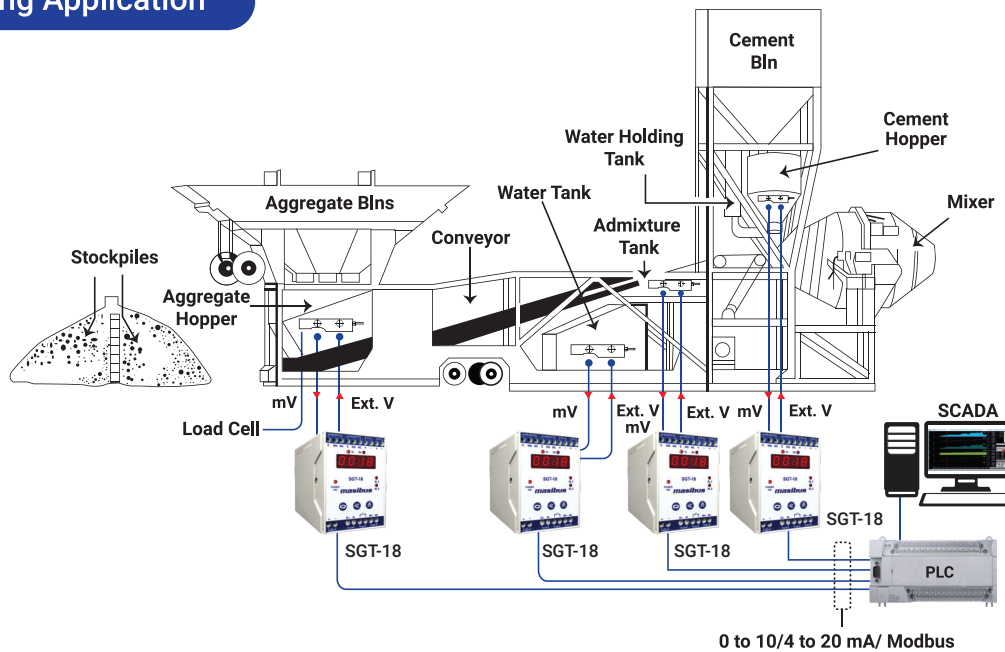

UT-94 Universal Transmitter

Features

- Compact DIN-Rail mounting
- Digital display
- Easy configuration using keys & display
- Micro controller based transmitter
- Measuring parameters: RTD, TC, mV, V, mA, Ω
- Upto two re-transmission output
- Two relay output (Optional)
- Modbus protocol on RS-485 (Optional)
- Square root extraction for linear input type



UT-94

Technical Specification

Models		TT7S00-HR	TT7S10	TT7S10-H	TT7S10-D
Supply	Loop Powered	✓	✓	✓	✓
	Aux Powered	✗	✗	✗	✗
Input	Factory Set Fixed (Pt-100)	✓	✗	✗	✗
	Universal	✗	✓	✓	✓
	Humidity and Temperature	✗	✗	✗	✗
	Differential Pressure	✗	✗	✗	✗
	Tap	✗	✗	✗	✗
	Strain Gauge/Load Cell	✗	✗	✗	✗
Output	Display	✗	✗	✗	✓
	Dual Analog Output	✗	✗	✗	✗
	Relays	✗	✗	✗	✗
Mounting	Head Mount	✓	✗	✓	✗
	DIN Rail Mount	✗	✓	✗	✓
	Wall Mount	✗	✗	✗	✗
	Duct Mount	✗	✗	✗	✗
Enclosure	Ex-Proof	✗	✗	✗	✗
Communication	Modbus-RTU	✗	✓	✓	✓
Isolation	Isolated Transmitter	✗	✓	✓	✓
Accuracy	PT100	±0.1 % of span	0.1% of FS, ± 1°	0.1% of FS, ± 1°	0.1% of FS, ± 1°
	Thermocouple (E,J,K,T,N)	–	0.1% of FS, ± 1°	0.1% of FS, ± 1°	0.1% of FS, ± 1°
	Thermocouple (B, R, S)	–	0.25% of FS, ± 1°	0.25% of FS, ± 1°	0.25% of FS, ± 1°
	Linear, Potentiometer	–	0.25% of FS, ± 1°	0.25% of FS, ± 1°	0.25% of FS, ± 1°
	RHT/DPT/SGT	–	–	–	–
	Temp-co	≤150 PPM/°C	≤150 PPM/°C	≤150 PPM/°C	≤150 PPM/°C
Response time		≤0.2 Sec.	≤500 mSec.	≤500 mSec.	≤1 Sec.

- Transmitters

TT7S10-XP	TT7S11S	UT-94	HT7S11S	DPT7S10	TPT-20	SGT-18
✓	✗	✗	✓	✓	✗	✗
✗	✓	✓	✓	✓	✓	✓
✗	✗	✗	✗	✗	✗	✗
✓	✓	✓	✗	✗	✗	✗
✗	✗	✗	✓	✗	✗	✗
✗	✗	✗	✗	✓	✗	✗
✗	✗	✗	✗	✗	✓	✗
✗	✗	✗	✗	✗	✗	✓
✓	✗	✓	✓	✓	✓	✓
✗	✗	✓	✗	✗	✓	✓
✗	✗	✓	✗	✗	✓	✓
✗	✗	✗	✗	✗	✗	✗
✗	✓	✓	✗	✗	✓	✓
✓	✗	✗	✓	✓	✗	✗
✗	✗	✗	✓	✗	✗	✗
✓	✗	✗	✓	✗	✗	✗
✓	✓	✓	✓	✓	✓	✓
✓	✓	✓	✓	✓	✓	✓
0.1% of FS, ± 1°	0.1% of FS, ± 1°	0.1% of FS, ± 1°	-	-	-	-
0.1% of FS, ± 1°	0.1% of FS, ± 1°	0.1% of FS, ± 1°	-	-	-	-
0.25% of FS, ± 1°	0.25% of FS, ± 1°	0.25% of FS, ± 1°	-	-	-	-
0.25% of FS, ± 1°	0.25% of FS, ± 1°	0.25% of FS, ± 1°	-	-	-	-
-	-	-	±2.5% (0 to 90% RH) ±3.5% (90 to 100% RH), ±0.6 °C	Pa : +/- 0.5% Span +/- 2 Pa mmWC: +/- 0.5% Span +/- 0.2 mWC	-	0.1 % of Full span ± 1 digit
≤150 PPM/°C	≤150 PPM/°C	≤100ppm/°C	-	-	-	-
≤1 Sec.	≤500 mSec.	≤200 mSec.	12 Sec. typically	2 Sec.	-	-

masibus[®]

A Sonepar Company

Masibus Automation And Instrumentation Pvt. Ltd.

Gandhinagar

Address: B-30, G.I.D.C. Electronic Estate,
Sector - 25, Gandhinagar - 382 024,
Gujarat, India
E-mail: sales@masibus.com
Ph. No.: +91 9662042824

Goa

Address: C-6, Phase 1-A, Verna Industrial
Estate, Verna, Salcette - 403722,
Goa, India
E-mail: sales@masibus.com
Ph. No.: +91 9822135796

Sharjah

Address: A2-102, SAIF Zone, PO Box
120145 Sharjah, UAE
E-mail: sharjahall@masibus.com
Ph. No.: +971 65574650

Bengaluru

E-mail: sales@masibus.com
Ph. No.: +91 8732971943

Chennai

E-mail: sales@masibus.com
Ph. No.: +91 9725154195

Delhi

E-mail: sales@masibus.com
Ph. No.: +91 9909949742

Hyderabad

E-mail: sales@masibus.com
Ph. No.: +91 9909949062

Kolkata

E-mail: sales@masibus.com
Ph. No.: +91 9512003359

Mumbai

E-mail: sales@masibus.com
Ph. No.: +91 9689937234

Pune

E-mail: sales@masibus.com
Ph. No.: +91 9689937234

E-mail: sales@masibus.com
Website: www.masibus.com

Sales Service: TOLL FREE (India)

1-800-233-2273

Sonepar India Pvt. Ltd.

Gurgaon

Address: Plot No. 229/239, Village -
Kherki Daula, Sector 76, Gurugram,
Haryana, 122004, India

Kolkata

Address: 503, Block 4B, Ecospace
Business Park, Newtown, Rajarhat,
Kolkata, West Bengal, 700160, India

Chennai

Address: Plot No. 1, Gokul Garden,
Melnallathur, Thiruvallur, Chennai,
Tamil Nadu, 602002, India

Aurangabad

Address: FP-42, Five Star Industrial Area,
Shendra MIDC, Aurangabad,
Maharashtra, 431201, India

Panchkula

Address: Plot No. 263, Industrial Area,
Phase-II, Panchkula, Haryana,
134113, India

Bhubaneswar

Address: Plot No. 443, 1st Floor,
Saheed Nagar, Bhubaneswar,
Odisha, 751007, India

E-mail: communications@soneparindia.com
Website: www.soneparindia.com