



**9000LE
Signal Isolator**



SPECIFICATION

INPUT	
Input Type	Current
Input Range	4 to 20mA
Input Impedance	≤30Ω
Temperature Coefficient	≤50 ppm/°C
CMRR	≥ 100 dB
NMRR	≥ 70 dB
No. of IO channels	one/two

OUTPUT	
Output Type	Current
Output Range	4 to 20mA
Response time	≤ 50μs
Accuracy	± 0.1% of FS
Output Load Resistance	≤500Ω@20mA
Transmitter Power Supply (Optional)	Open circuit voltage: ≥24VDC Available voltage ≥ 23VDC @ 4mA, ≥ 16VDC @ 20mA
Communications supported	HART pass supported in both channels with 2W transmitter only (With TPS Model)

POWER SUPPLY	
Voltage	20 to 35 VDC
Power Consumption	With TPS: ≤1.3W/Channel Without TPS: ≤0.7W/Channel
Power ON status LED	Red

Isolation	
Between Power to Inputs and Outputs:	Galvanic Isolation of 2KVAC for 1 minute
Between Inputs to Outputs:	Galvanic Isolation of 2KVAC for 1 minute
Between Input to Input:	Galvanic Isolation of 2KVAC for 1 minute
Between Output to Output:	Galvanic Isolation of 2KVAC for 1 minute
Insulation resistance:	>200MΩ@1000V DC between All Ports.

PHYSICAL	
Mounting Type	DIN Rail (35 mm)
Terminal Block	UL,CSA standard
Terminal Cable Size	2.5mm ²
Enclosure Material	ABS
IP Rating	IP20
Dimension (in mm)	75(H)x35(W)x107(D)
Weight	≤200 g

ENVIRONMENTAL

Operating temperature	-20 to 60°C
Storage temperature	-30° to 70°C
Relative Humidity	30% to 95% RH (Non-Condensing)
Protection	Conformal Coating on PCB

SAFETY/WARNING PRECAUTIONS

To avoid Electrostatic Discharge (ESD) to the transmitter, that may cause permanent damage, Operator must operate device using ESD safe tools and clothing.

Terminal wiring:

Check that all cables are correctly connected according to the connection diagram. Before installation or beginning of any troubleshooting Procedures, the power to all equipment must be turned off and isolated. Units suspected of being faulty must be Disconnected and removed first and brought to a properly equipped workshop for testing and repair.

Component replacement and internal adjustments must be done either by Masibus or done under the guidance of Masibus. Wiring must be carried out by skilled personnel and correct tools.

All wiring must confirm with standards of good practice and local codes and regulations. Wiring must be suitable for voltage, current, and temperature rating of the system. Beware not to over-tighten the terminal screws.

WARRANTY

Warranty does not apply to defects resulting from action of the user such as misuse, improper wiring, operation outside of specification, improper maintenance or repair, or unauthorized modification.

Masibus is not liable for special, indirect or consequential damages or for loss of profit or for expenses sustained as a result of a device malfunction, incorrect application or adjustment.

Masibus total liability is limited to repair or replacement of the product. The warranty set forth above is inclusive and no other warranty, whether written or oral, is expressed or implied.

MECHANICAL INSTALLATION AND REMOVAL

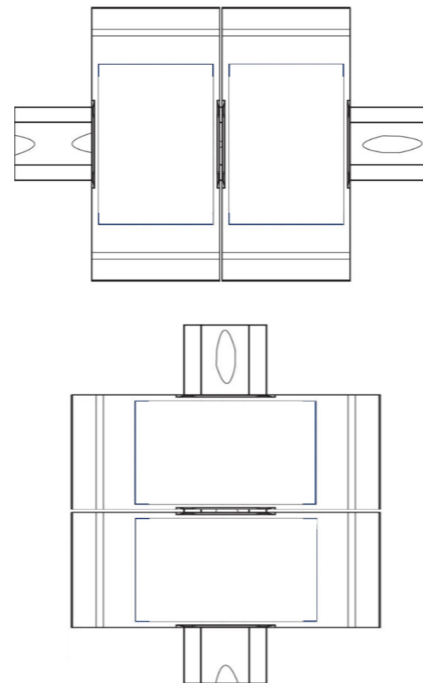

DIMENSIONS

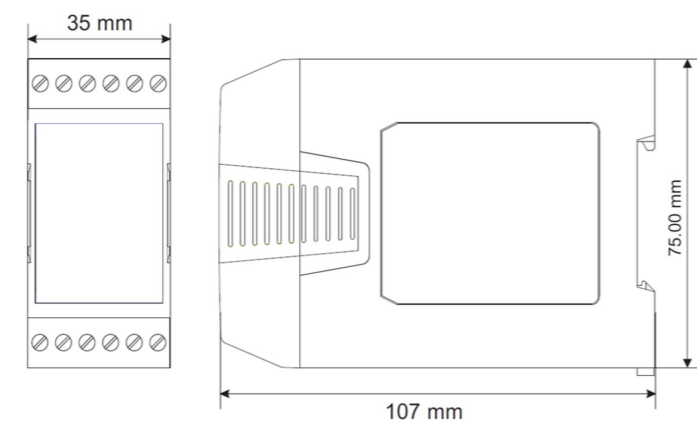

TERMINAL CONNECTION

2-W Connection Diagram

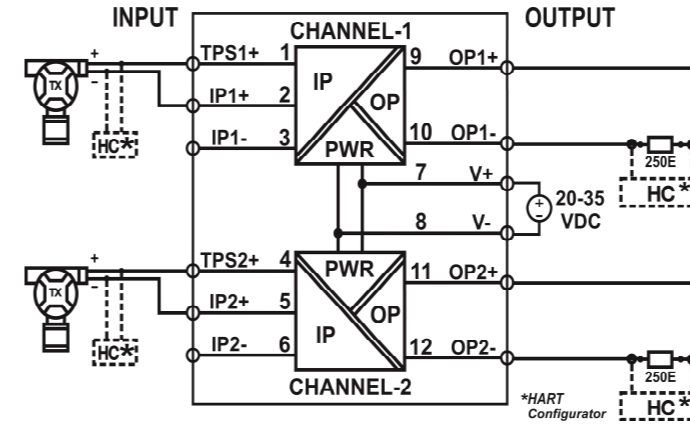

4-W Connection Diagram

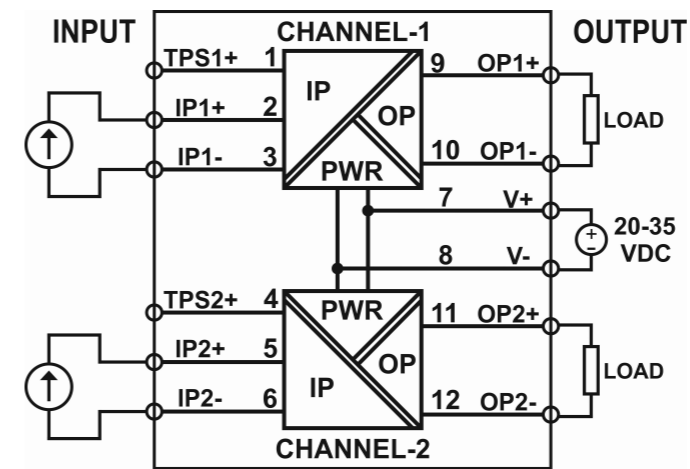

2-W Single Input Dual Output Configuration

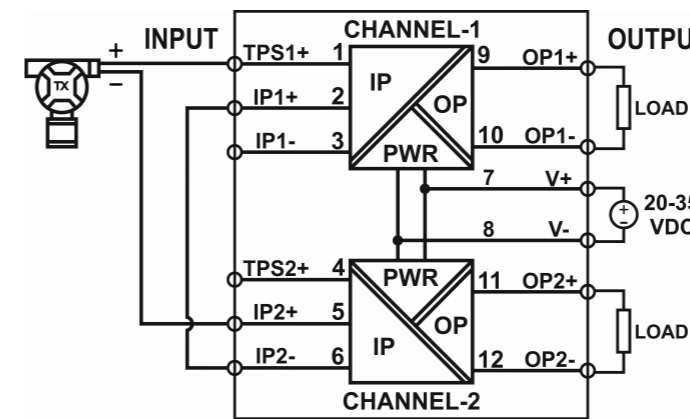

4-W Single Input Dual Output Configuration

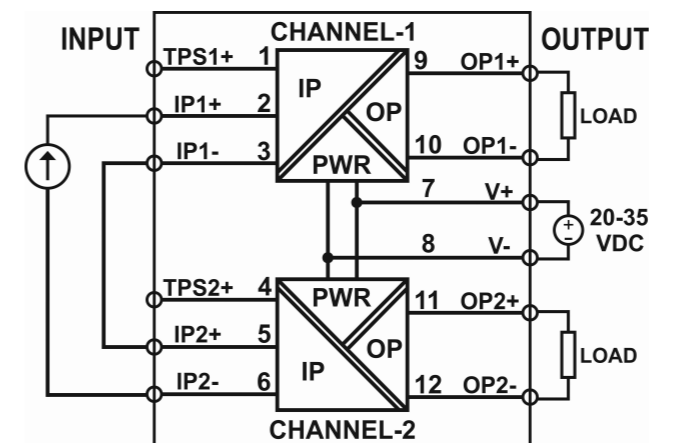

TROUBLE SHOOTING

Unit Not Turn ON:

If Red LED at the front side is not turned "ON", the device is not getting sufficient supply or the connections are not as per terminal details.

Output not matching with expected value?

Make sure the load on output of device is as per specification criteria. Make sure the output Signal is really incorrect with respect to input signal before attempting any re-calibration.

Unstable Reading?

Check for loose connections. First verify that all conventional instrumentation norms have been followed for wiring. Make noise away from signal isolator.

If still problem, contact Masibus.



B/30, GIDC Electronics Estate,
Sector-25, Gandhinagar-382024, Gujarat, India
☎ +91 79 23287275-77 📧 +91 79 23287281
Email: support@masibus.com
Web: www.masibus.com