

# User's Manual **DDU-XX** Digital Display Unit

- DDU-TM (Time)
- DDU-DT (Date)
- DDU-TD (Time & Date)
- DDU-DY (Day)
- DDU-CL (Calendar)
- DDU-HZ (Frequency)



## Masibus Automation And Instrumentation Pvt. Ltd.

B/30, GIDC Electronics Estate,  
Sector-25, Gandhinagar-382024, Gujarat, India  
☎ +91 79 23287275-77 📠 +91 79 23287281  
Email: [support@masibus.com](mailto:support@masibus.com)  
Web: [www.masibus.com](http://www.masibus.com)

## CONTENTS

<b>1. INTRODUCTION .....</b>	<b>4</b>
Foreword .....	4
Notice .....	4
Trademarks .....	4
Checking the Contents of the Package.....	4
Product Ordering Code .....	4
List of Accessories .....	5
Safety Precautions.....	6
<b>2. SPECIFICATIONS.....</b>	<b>7</b>
2.1 Technical Specification Sheet.....	7
2.2 Time Signal Input .....	9
2.3 Frequency Signal Input.....	9
<b>3. FRONT PICTURE .....</b>	<b>10</b>
3.1 DDU-TM IP20 Front view .....	10
3.2 DDU-TD Date & Time IP20 Front view.....	10
3.3 DDU-CL IP20 Front view .....	10
3.4 DDU-Hz IP20 Front view .....	10
3.5 DDU-DY IP20 Front view .....	11
3.6 DDU-TM IP65 Front view .....	11
3.7 DDU-Hz IP65 Front view .....	11
3.8 DDU-DY IP65 Front view .....	11
<b>4. INSTALLATION &amp; MOUNTING DETAIL.....</b>	<b>12</b>
4.1 Safety Precautions in Installation .....	122
4.2 IP20 Wall Mount .....	133
4.3 IP20 Rack Mount.....	155
4.4 IP20 Table Top .....	177
4.5 IP65 Wall Mount .....	179
4.6 IP65 Hanging Type.....	20
<b>5. TERMINAL CONNECTIONS .....</b>	<b>22</b>
5.1 Terminal connections on IP20 Enclosures .....	22
5.2 Terminal connections on IP65 Enclosures .....	23
5.3 How to connect wires .....	24
<b>6. CONFIGURATION GUIDELINES .....</b>	<b>25</b>
6.1 Default Configuration .....	25
6.2 Switch Selection for Configuration.....	25

6.3 Configuration Command for NTP [For Time/Date and Day & Calendar].....	28
6.4 Serial Configuration [For Time/Date and Day & Calendar] .....	40
<b>7. OPERATION INFORMATION .....</b>	<b>64</b>
7.1 Operation as Time/Date and Day Display [DDU-TD] & Calendar Display [DDU-CL]	64
7.2 Operation as Frequency Display. ....	66
<b>8. COMMUNICATION GUIDELINES.....</b>	<b>68</b>
8.1 Serial Time Frame Input .....	68
8.2 NTP Packet format: .....	69
8.3 The IRIG-B Signal .....	71
8.3 Serial Frame Format for Frequency Data INPUT .....	72
8.4 Serial Frame Format for Frequency Data OUTPUT.....	74
8.5 UDP Packet Format for Frequency Display Unit .....	74
<b>9. TROUBLESHOOTING TIPS.....</b>	<b>75</b>
<b>10. REVISION HISTORY.....</b>	<b>788</b>

## 1. INTRODUCTION

### Foreword

Thank you for purchasing Display Unit

<b>DDU-TM</b>	<b>(Time Display Unit, 4" [100 mm], 6 LED Display) /</b>
<b>DDU-DT</b>	<b>(Date Display Unit, 4" [100 mm], 6 LED Display) /</b>
<b>DDU-TD</b>	<b>(Time &amp; Date Display Unit, 4" [100 mm], 12 LED Display) /</b>
<b>DDU-DY</b>	<b>(Day Display Unit, 4" [100 mm], 3 DOT Matrix Display) /</b>
<b>DDU-HZ</b>	<b>(Frequency Display Unit, 4" [100 mm], 4 or 5 LED Display) /</b>
<b>DDU-CL</b>	<b>(Time, Date &amp; Day Display Unit, 4" [100 mm] &amp; 2.3"[57mm], 2"[50mm], 12 LED Display &amp; 5x8 DOT Matrix Display)</b>

This manual describes the basic functions and operation methods. Please read through this user's manual carefully before using the product.

### Notice

For Configuration mode of DDU-HZ, please refers product annexure. In this manual Serial configuration and Telnet is for Time, Date and Day Display Unit.

The contents of this manual are subject to change without notice as a result of continuous improvements to the instrument's performance and functions.

Every effort has been made to ensure accuracy in the preparation of this manual. Should any errors or omissions come to your attention, however, please inform MASIBUS Sales office or sales representative. Under no circumstances may the contents of this manual, in part or in whole, be transcribed or copied without our permission.

### Trademarks

Our product names or brand names mentioned in this manual are the trademarks or registered trademarks of Masibus Automation and Instrumentation (P) Ltd. (herein after referred to as **masibus**).

Adobe, Acrobat, and Postscript are either registered trademarks or trademarks of Adobe Systems Incorporated. All other product names mentioned in this user's manual are trademarks or registered trademarks of their respective companies.

### Checking the Contents of the Package

Unpack the box and check the contents before using the product. If the product is different from which you have ordered, if any parts or accessories are missing, or if the product appears to be damaged, contact your sales representative.

### Product Ordering Code

Ordering Code for Time / Date/ Day Display Unit												
Model	Display Type		Mounting		Input Type 1		Input Type 2		Input Type 3		Input Type 4	
DDU	XX		X		X		X		X		X	
	TM	Time	T	Table Top (IP20)	1	RS 232	N	None	N	None	N	None
	DT	Date	R	Rack / Panel (IP20)	2	RS 485	1	SNTP / NTP	1	IRIG-B MOD	1	IRIG-B TTL
	DY	Day	W0	Wall (IP20)								
	TD#	Time & Date	W1	Wall (IP65)								
	CL#	Calendar	H1	Hanging Type (IP65)								
	SP*	Special										

**Note: -**  
**X - Specify From Table**  
 #: Available in IP20 & Table, Panel/Rack type mount only  
 \*: For Special display type & 8 digit Display unit contact factory

Ordering Code for Frequency Display Unit				
Model	Display Type	X	Mounting	Input Type
DDU	XX	X		X
	HZ	Frequency	T	Table Top (IP20)
			R	Rack / Panel (IP20)
			W0	Wall (IP 20)
			W1	Wall (IP 65)
			H1	Hanging Type (IP 65)
				6

**Note: -**  
 For Frequency display unit in case of Ethernet or Line Frequency input type, RS232 serial port will be given for firmware up gradation




**Note: -**  
 For Display Color Other than RED, please specify at the time of Order applicable as mentioned in Technical Specifications

The unit has a nameplate affixed to the one side of the enclosure. Check the model and suffix codes inscribed on the nameplate to confirm that the product received is that which was ordered.

### List of Accessories

The product is provided with the following accessories according to the model and suffix codes (see the table below). Check that none of them are missing or damaged.

No	Item name	Part number	Qty	Remarks
1	Mounting Clamps	-	2	For IP20 Wall Mount
			4	For IP65 Wall Mount
			2	With Handle for IP20 Rack Mount
			2	IP20 Table top Clamp
2	I Bolt for Hanging	-	4	For IP65 Hanging Type
3	Serial Configuration Cable for RS232 IP20 Enclosure LABEL: DDU-CNFG-S1-02	-	2 Mtrs	8 cores, One side 9 pin Male and other side 9 pin Female connector, Straight Cable. (Applicable for Model: - DDU-TM, DDU-TD. DDU-CL)
4	Serial Synchronization Cable for RS232 IP20 Enclosure LABEL: DDU-SYNC-S1-02	-	2 Mtrs	Both Side 9 pin Male connector, Strait Cable. (Applicable for Model:-DDU-TM, DDU-TD. DDU-CL)
5	Serial synchronization Cable for RS485 IP20 Enclosure GPSCNFG /DDUSYNC-S2-02	-	2 Mtrs	2 pair twisted cable, 9-pin D-connector Male & other side Ferrule (D+ & D-) ( Applicable in case of RS485 input is selected for model:- DDU-TM, DDU-TD & DDU-CL)
6	Serial Configuration Cable for RS232 IP65 Enclosure DDUTDC-CNFG-S1-02	-	2 Mtrs	8 cores, Single side, 9-pin D-connector Female & other side Ferrule (TX,RX & GND) (Applicable for Model:-DDU-TM)
7	Serial Synchronization Cable for RS232 IP65 Enclosure DDUTDC-SYNC-S1-02	-	2 Mtrs	8 cores, Single side, 9-pin D-connector Male & other side Ferrule (TX,RX & GND) (Applicable for Model:-DDU-TM)
8	Serial Configuration Cable for RS232 IP65 Enclosure DDUTDC-CNFG-S1-02	-	2 Mtrs	8 cores, Single side, 9-pin D-connector Male & other side Ferrule (TX,RX & GND) (Applicable for Model:-DDU-TM)
9	RJ45 Cable for Ethernet port	-	2 Mtrs	Standard Ethernet Cable ( Applicable in case of NTP/SNTP input is selected for Model:- DDU-TM, DDU-TD, DDU-CL)

Accessories (Optional-On request)					
Extra Mounting Clamp for IP20 Enclosure					
Wall		Rack/Panel			Table Top
m-MK-FW-50-1 [177mm Height Unit]	m-MK-FW-50-2 [266 & 355mm Height Unit]	m-MK-FPL-50-1 [177mm Height Unit]	m-MK-FPL-50-2 [266mm Height Unit]	m-MK-FPL-50-3 [355mm Height Unit]	m-MK-TT-50-1
					

### Safety Precautions



The product and the instruction manual describe important information to prevent possible harm to users and damage to the property and to use the product safely.

Understand the following description (signs and symbols), read the text and observe descriptions.

#### DESCRIPTION OF SIGNS

**Note:**

*For Frequency display unit in case of Ethernet or Line Frequency input type, RS232 serial port will be given for firmware up gradation*


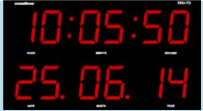







	<b>WARNING</b>	<i>This indicates a danger that may result in death or serious injury if not avoided.</i>
	<b>CAUTION</b>	<i>This indicates a danger that may result in minor or moderate injury or only a physical damage if not avoided.</i>

## 2. SPECIFICATIONS

### 2.1 Technical Specification Sheet

	Time/Date Display	Time & Date Display	Day Display	Frequency Display	Calendar Display (Date, Time, Day)
<b>Display</b>					
<b>No of Digit</b>	Six / Eight <sup>1</sup> (Date Only)	Time: Six Digit Date: Six Digit	Three Digits	Five Digits	Time: Six Digit Date: Six Digit Day: Three Digit
<b>Digit Height</b>	4" (100 mm)				Time: 4"(100 mm) Date: 2.3"(57 mm) Day: 2"(50 mm)
<b>Type of display</b>	7-Segment	7-Segment	5x7 dot matrix Type	7-Segment	Time: 7-Segment Date: 7-Segment Day: 5x7 dot matrix Type
<b>Display Colors<sup>2</sup></b>	Red / Amber / Green / Blue	Time: Red Date: Red / Amber	Red / Amber / Green / Blue	Red / Amber / Green / Blue	Time: Red Date: Red / Green Day: Red / Amber
<b>Display Format</b>	Time: HH:MM:SS Date: DD.MM.YY / MM.DD.YY / YY.MM.DD	Time: HH:MM:SS Date: DD.MM.YY / MM.DD.YY / YY.MM.DD	DDD	XX.XXX	Time: HH:MM:SS Date: DD.MM.YY / MM.DD.YY / YY.MM.DD Day: DDD
<b>Lock/Unlock Indicator</b>	✓	✓	✓	NA	✓
<b>12/24 Hour Mode</b>	✓	✓	NA	NA	✓
<b>AM/PM Indication</b>	✓	✓	NA	NA	✓
<b>International Time Zone</b>	✓	✓	✓	NA	✓
<b>User Interface</b>					
<b>Serial Configuration [Hyper terminal]</b>	✓	✓	✓	NA	✓
<b>Telnet CLIENT [with LAN Interface only]</b>	✓	✓	✓	NA	✓
<b>Password Protected</b>	✓	✓	✓	NA	✓
<b>DIP Switch</b>	NA	NA	NA	✓	NA
<b>Signal Input</b>					
<b>RS232/RS485</b>	✓	✓	✓	✓	✓

Model: DDU-XX  
 Doc. Ref. no. : - m06om301  
 Issue no. 08

IRIG-B TTL[PWM]	✓	✓	✓	NA	✓
IRIG-B Modulated	✓	✓	✓	NA	✓
NTP (LAN Interface) Ethernet in case of Frequency i/p	✓	✓	✓	✓	✓
Line Frequency Input	NA	NA	NA	✓	NA
<b>Connectors</b>					
RS-232 [DB9]/ RS-485 [Standard 3-pin Plug-in Type]	✓	✓	✓	✓	✓
Ethernet, 100 BaseT, RJ-45	✓	✓	✓	✓	✓
Power, Standard 3-pin Plug-in Type	✓	✓	✓	✓	✓
<b>Mechanical</b>					
IP20 Protection					
Size [W x H x D] [in mm] [Without Mounting Bracket]	646 x 177 x 68	646 x 355 x 68	326 x 177 x 68	646 x 177 x 68	646 x 266 x 68
Weight(approx.)	4.5Kg	7.32 Kg.	2.5Kg	4.5Kg	5.5 Kg.
Material	Aluminum with powder coat paint inside & out				
Front Acrylic	Smoke Grey Acrylic				
Mounting	Rack Mount / Wall Mount / Table Top				
IP65 Protection					
Size [W x H x D] [in mm]	800 x 200 x 120	800 x 400 x 120	400 x 200 x 120	800 x 200 x 120	NA
Weight(approx.)	9 Kg.	16 Kg.	3.3 Kg.	9 Kg.	NA
Material	1.2mm mild steel with powder coat paint inside & out				
Front Acrylic	Smoke Grey Acrylic				
Mounting	Hanging Type/ Wall Mount				
<b>Power Supply</b>					
Power	AC: 90-264 V, 47-63 Hz, 1Ph & DC: 90-300 V				
Power Consumption	<10W	<20W	<10W	<10W	<20W
<b>Environmental</b>					
Operating temperature	0 °C to +55 °C				
Storage temperature	-20 °C to +80 °C				
Humidity	20-90 % RH (Non-condensing)				



**Note** :-1. For 8 Digit Date display contact factory  
 2. For Display Color Other than RED, please specify at the time of Order

## 2.2 Time Signal Input

Input	Description	Physical Interface
Serial RS485	<ul style="list-style-type: none"> <li>Protocols: NMEA-0183[RMC] / NGTS/ T – Format</li> <li>Baud Rate: 4800/9600/19200/38400/57600/115200</li> </ul>	2 pin Plug-in type Connector [Cable Size: 2.5 <sup>2</sup> mm]
Serial RS232		9-Pin D type female for IP20 Enclosure, 3 pin Plug-in type Connector [Cable Size: 2.5 <sup>2</sup> mm] for IP65 Enclosure.
IRIG-B Modulated	<ul style="list-style-type: none"> <li>Format: IRIG-B12X</li> <li>Carrier Frequency: 1 KHz</li> <li>Modulation Ratio : 3:1</li> <li>3.3 Vpp (10K Input Impedance)</li> </ul>	BNC Female connector 2-pin Plug-in type Connector [Cable Size: 2.5 <sup>2</sup> mm] for IP65 Enclosure.
IRIG-B TTL (PWM)	<ul style="list-style-type: none"> <li>Format: IRIG-B00X</li> <li>TTL Input</li> <li>Impedance: 2KΩ @ 5V</li> </ul>	BNC Female connector 2-pin Plug-in type Connector [Cable Size: 2.5 <sup>2</sup> mm] for IP65 Enclosure.
NTP (LAN Interface)	<ul style="list-style-type: none"> <li>Time sync protocol: NTP V3, UDP, Telnet</li> <li>Internet protocol : IPv4, Mode: Client</li> <li>Protocol Time format : UTC</li> </ul>	RJ45, 10/100 Mbps

## 2.3 Frequency Signal Input

Input	Description	Physical Interface
Serial RS485	<ul style="list-style-type: none"> <li>Based on serial Frame[Broadcasted by Server]</li> <li>Baud Rate: 2400/4800/ 9600/19200</li> </ul>	2 pin Plug-in type Connector [Cable Size: 2.5 <sup>2</sup> mm]
Serial RS232		9-Pin D type female for IP20 Enclosure, 3-pin Plug-in type Connector [Cable Size: 2.5 <sup>2</sup> mm] for IP65 Enclosure.
AC Voltage Input	<ul style="list-style-type: none"> <li>63V, 110V &amp; 240VAC Input</li> <li>Voltage range is -30% to +25% of Selected input</li> <li>45-65 Hz, Input Frequency</li> </ul>	2-pin Plug-in type Connector [Cable Size: 2.5 <sup>2</sup> mm]
Ethernet (LAN Interface)	<ul style="list-style-type: none"> <li>Based on UDP[Broadcasted by Server]</li> </ul>	RJ45, 10/100 Mbps

### Isolation (Withstanding voltage)

- Between primary terminals\* and secondary terminals\*\*: At least 1500 V AC for 1 minute
- Between primary terminals\* and grounding terminal: At least 1500 V AC for 1 minute
- Between grounding terminal and secondary terminals\*\*: At least 1500 V AC for 1 minute
- Between secondary terminals\*\*: At least 1500 V AC for 1 minute

\* Primary terminals indicate power terminals.

\*\* Secondary terminals indicate RS232/485, IRIG-B TTL, IRIG-B Modulated and RJ-45.

There is no Isolation between RS-232/485 and IRIG-B TTL

**Insulation resistance:** 20MΩ or more at 500 V DC between power terminals and grounding terminal

### 3. FRONT PICTURE

---

#### 3.1 DDU-TM IP20 Front view



#### 3.2 DDU-TD Date & Time IP20 Front view



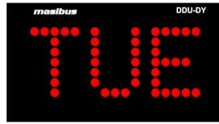
#### 3.3 DDU-CL IP20 Front view



#### 3.4 DDU-Hz IP20 Front view



### 3.5 DDU-DY IP20 Front view



### 3.6 DDU-TM IP65 Front view



### 3.7 DDU-Hz IP65 Front view



### 3.8 DDU-DY IP65 Front view



## 4. INSTALLATION & MOUNTING DETAIL

---

### 4.1 Safety Precautions in Installation



1. Turn off the power to the Instrument before installing it on the panel because there is a possibility of electric shock.
2. To minimize the possibility of fire or shock hazards, do not expose this instrument to rain or excessive moisture.
3. Do not use this instrument in areas under hazardous conditions such as excessive shock, vibration, dirt, moisture, corrosive gases or oil. The ambient temperature of the areas should not exceed the maximum rating specified.



Ground the device. Otherwise, it may cause an electric shock or fire.  
The protective conductor terminal is marked with a label on the product terminals with the following symbol:



Also insure that Earth Ground of the premises has been done properly.

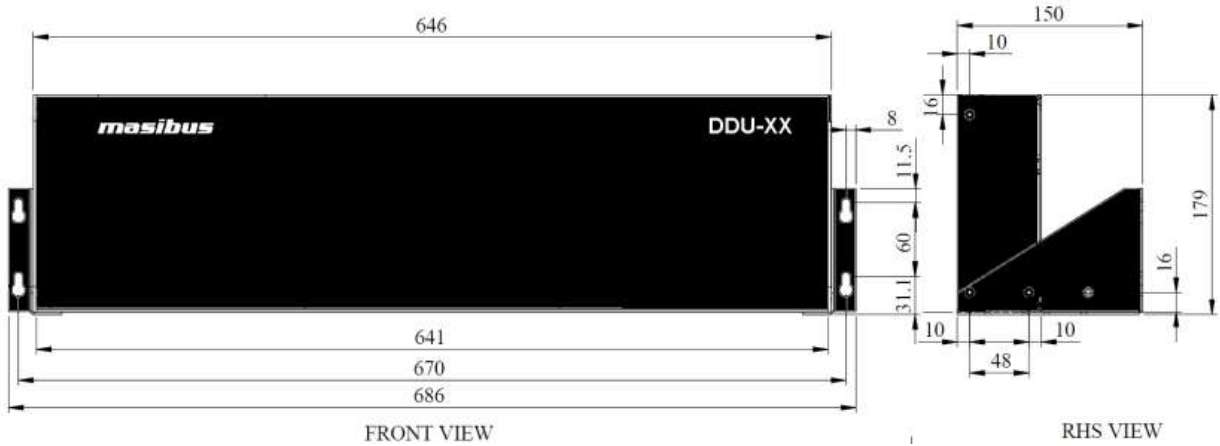


Be sure all personnel involved in installation, servicing, and programming are qualified and familiar with electrical equipment and their ratings

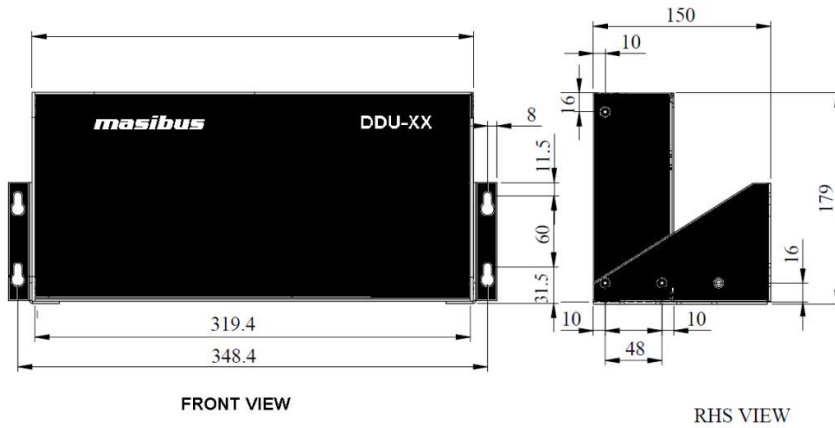
Do not install, store, or use it in the place with a lot of dust, corrosive and flammable gases, vibrations and shocks exceeding the allowed values, place low or high temperature outside of the installation condition, direct sunlight and near equipment generating strong radio waves or magnetic fields, It may cause accidents.

## 4.2 IP20 Wall Mount

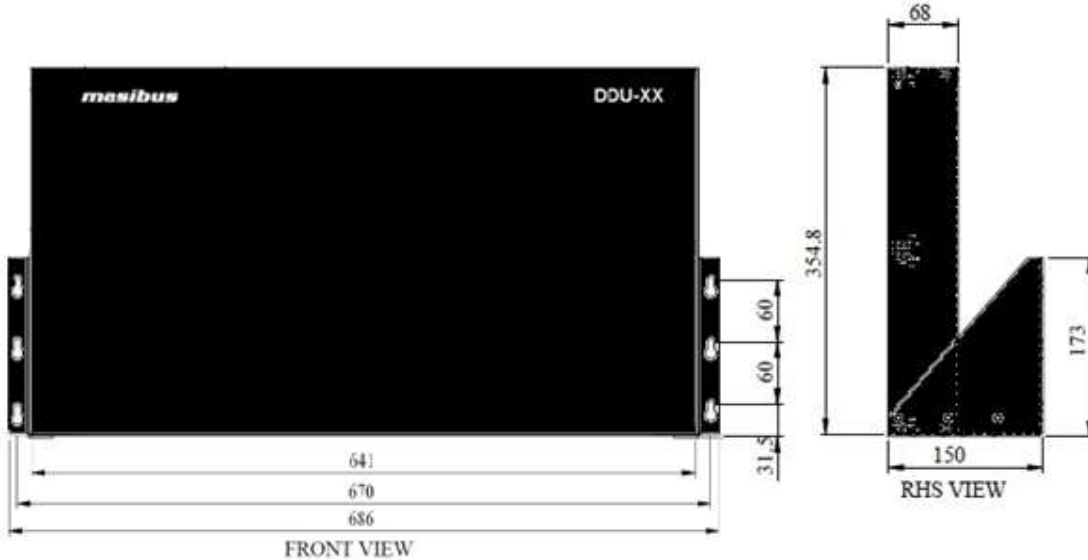
**Fig 4.2.1: Mounting detail for 126T/4U/68D [646mm x 177mm x 68mm] Enclosure**



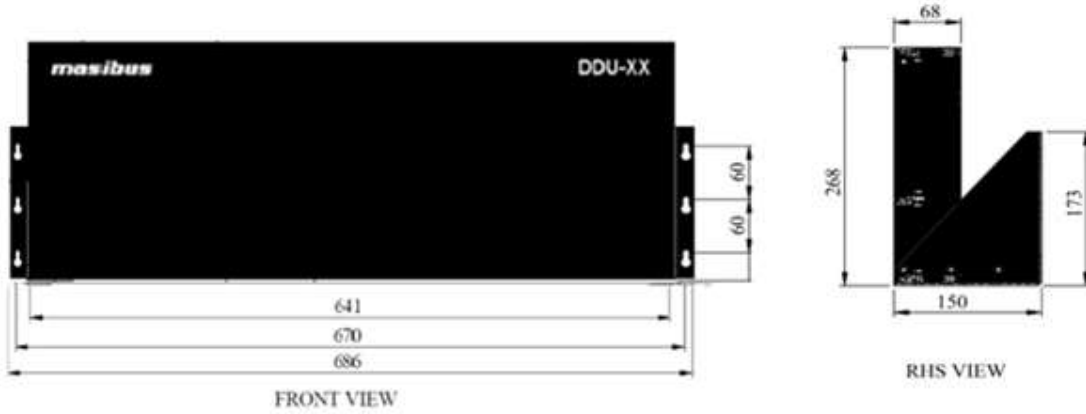
**Fig 4.2.2: Mounting detail for 63T/4U/68D [326mm x 177mm x 68mm] Enclosure**



**Fig 4.2.3: Mounting detail for 126T/8U/68D [646mm x 354.8mm x 68mm] Enclosure**



**Fig 4.2.4: Mounting detail for 126T/6U/68D [646mm x 266mm x 68mm] Enclosure**

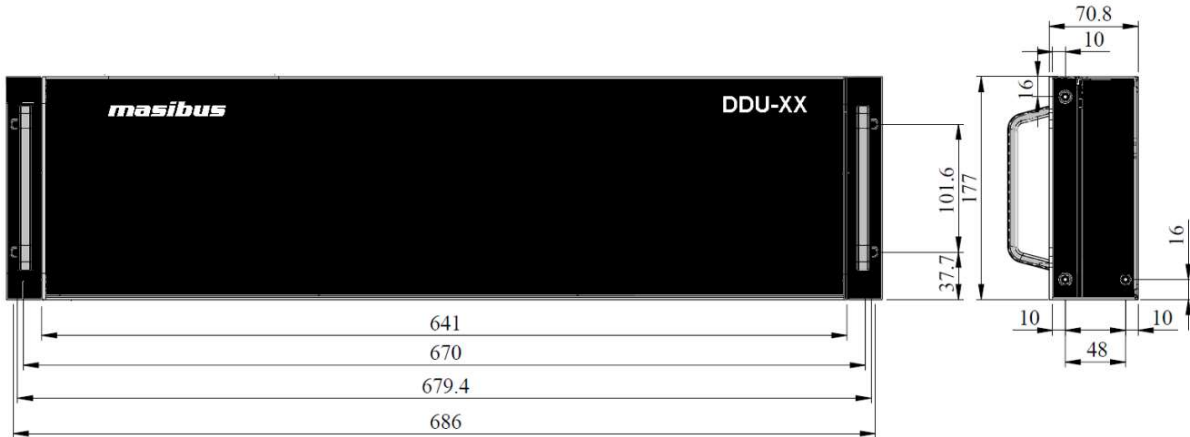


**Fig 4.2.5: CSK screw fitting information for wall mount Clamp**

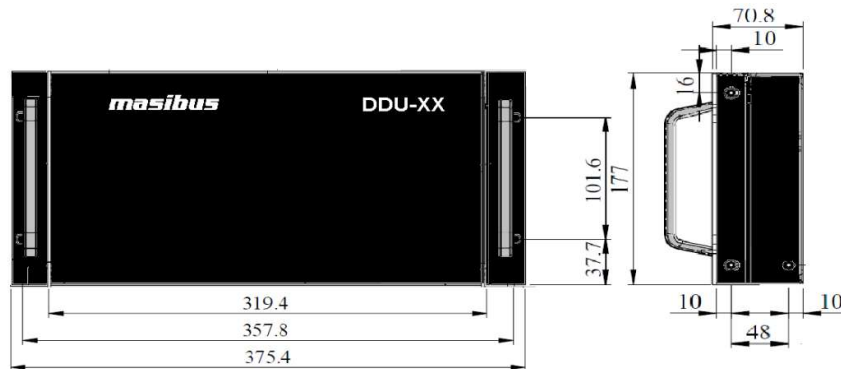


### 4.3 IP20 Rack Mount

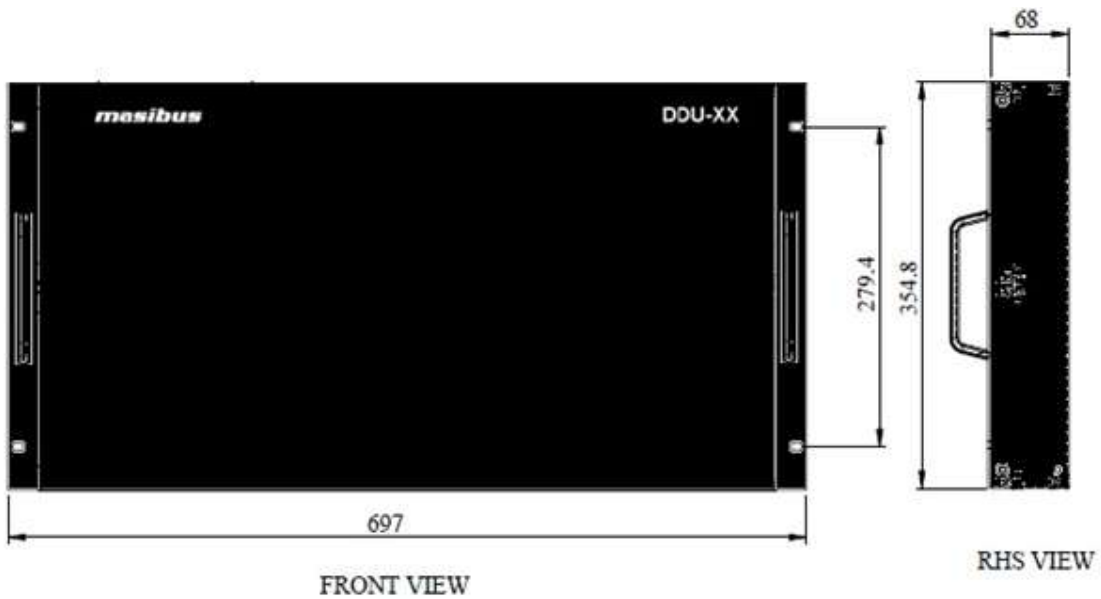
**Fig 4.3.1: Mounting detail for 126T/4U/68D [800mm x 200mm x 120mm] Enclosure**



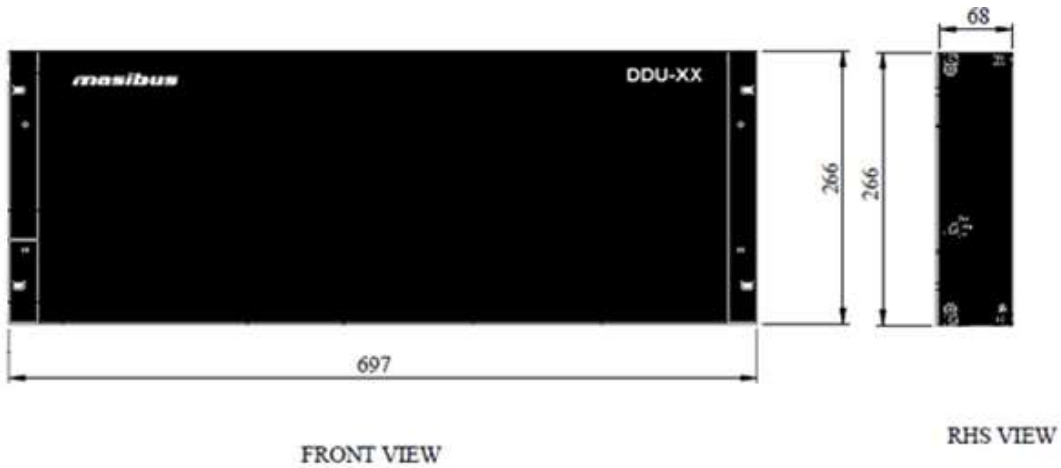
**Fig 4.3.2: Mounting detail for 63T/4U/68D[800mm x 200mm x 120mm] Enclosure**



**Fig 4.3.3: Mounting detail for 126T/8U/68D [646mm x 354.8mm x 68mm] Enclosure**



**Fig 4.3.4: Mounting detail for 126T/6U/68D [646mm x 266mm x 68mm] Enclosure**



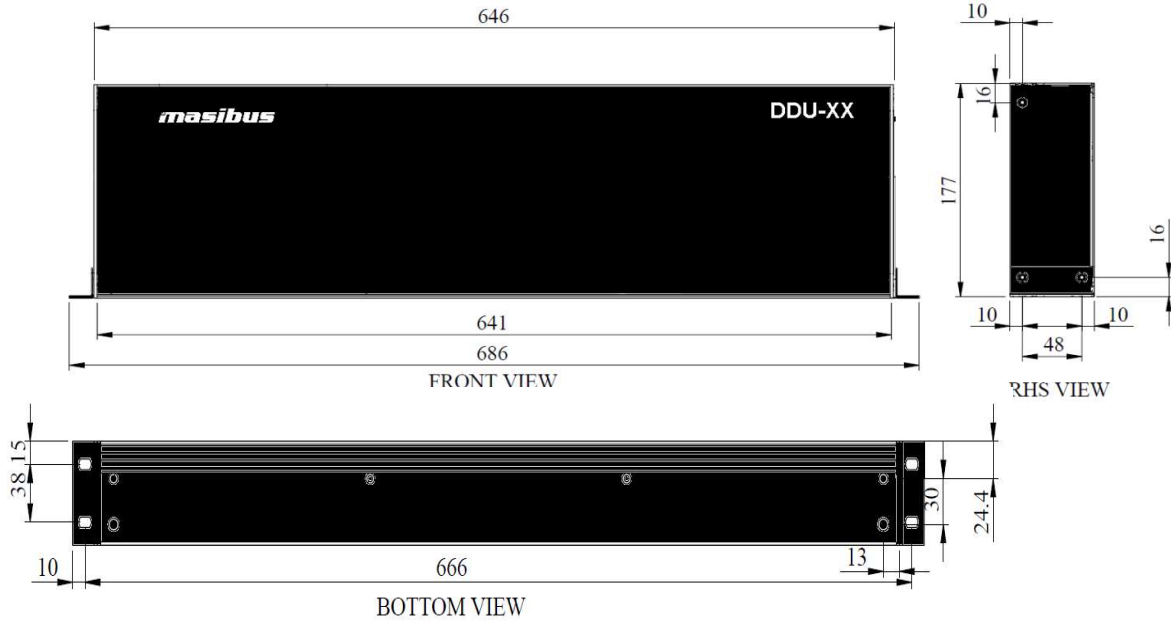
**Fig 4.3.5: CSK screw fitting information for panel mount Clamp**



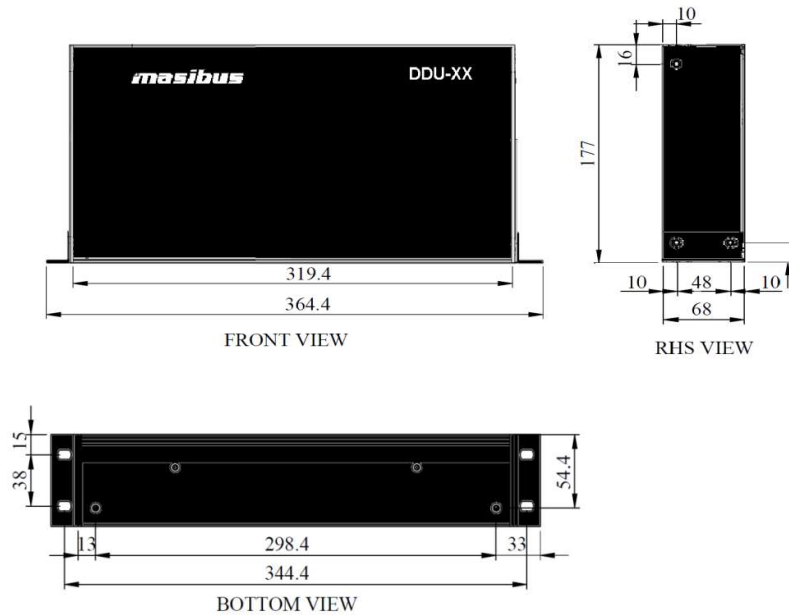


#### 4.4 IP20 Table Top

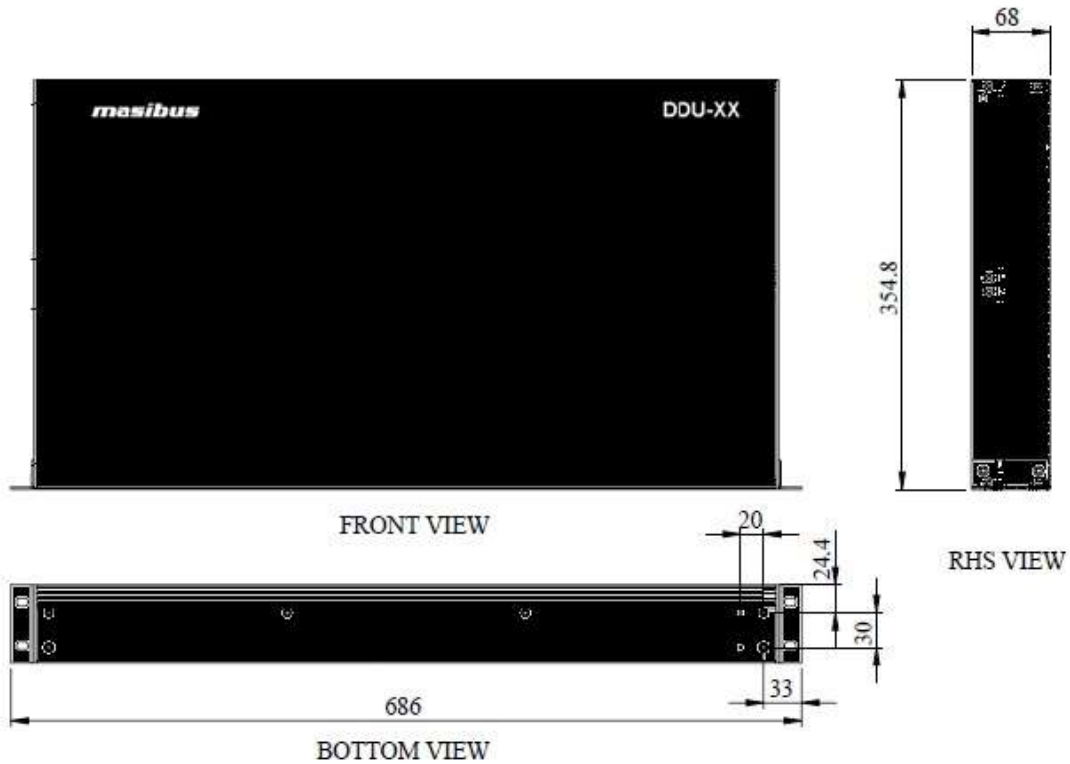
**Fig 4.4.1: Mounting detail for 126T/4U/68D [646mm x 177mm x 68mm] Enclosure**



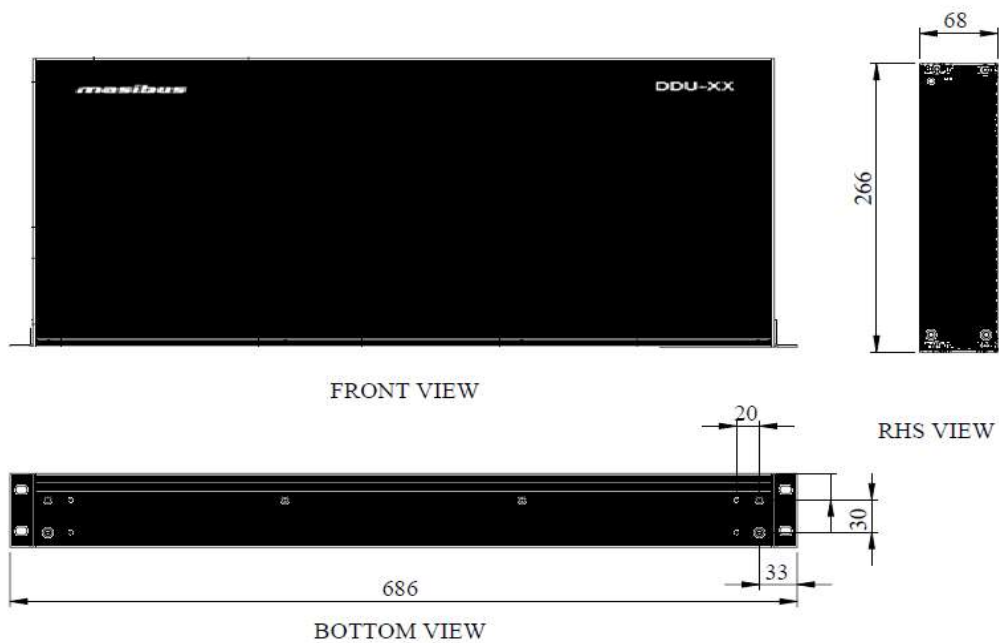
**Fig 4.4.2: Mounting detail for 63TT/4U/68D [326mm x 177mm x 68mm] Enclosure**



**Fig 4.4.3: Mounting detail for 126T/8U/68D [646mm x 354.8mm x 68mm] Enclosure**



**Fig 4.4.4: Mounting detail for 126T/6U/68D [646mm x 266mm x 68mm] Enclosure**

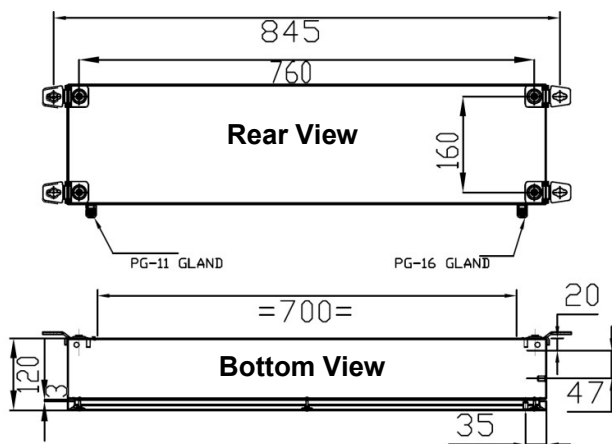


**Fig 4.4.5: CSK screw fitting information for Table Top Clamp**

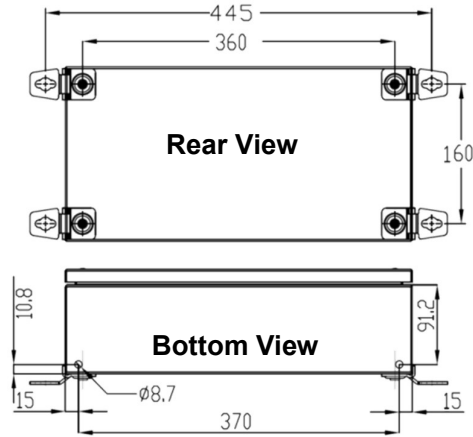


## 4.5 IP65 Wall Mount

**Fig 4.8: Mounting detail for 800mm x 200mm x 120mm Enclosure**

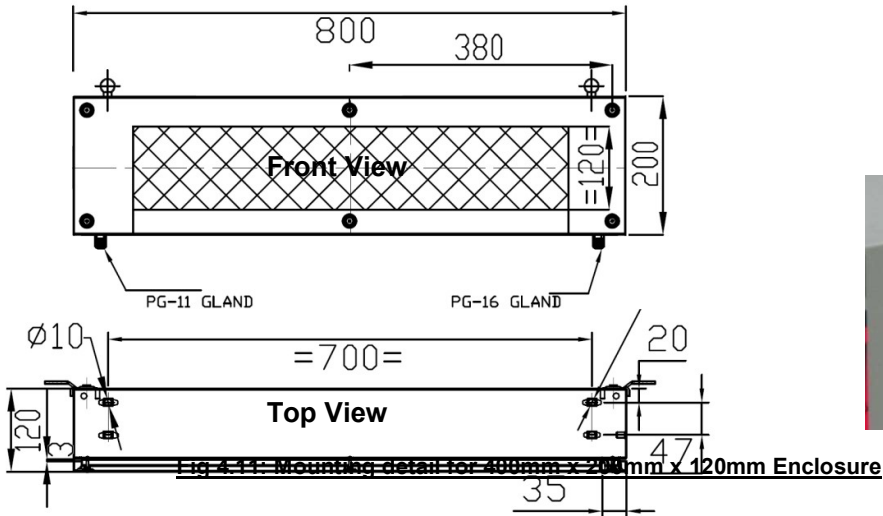


**Fig 4.9: Mounting detail for 400mm x 200mm x 120mm Enclosure**

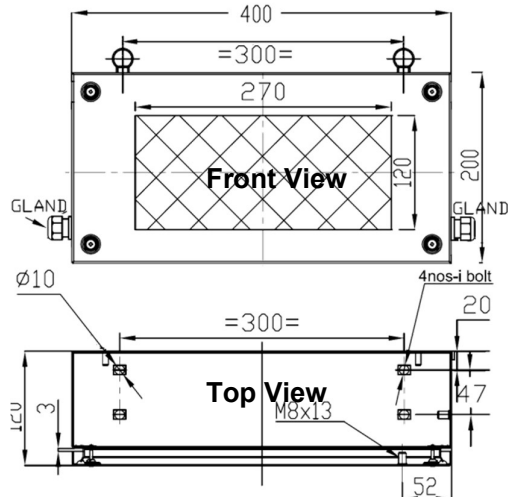


#### 4.6 IP65 Hanging Type

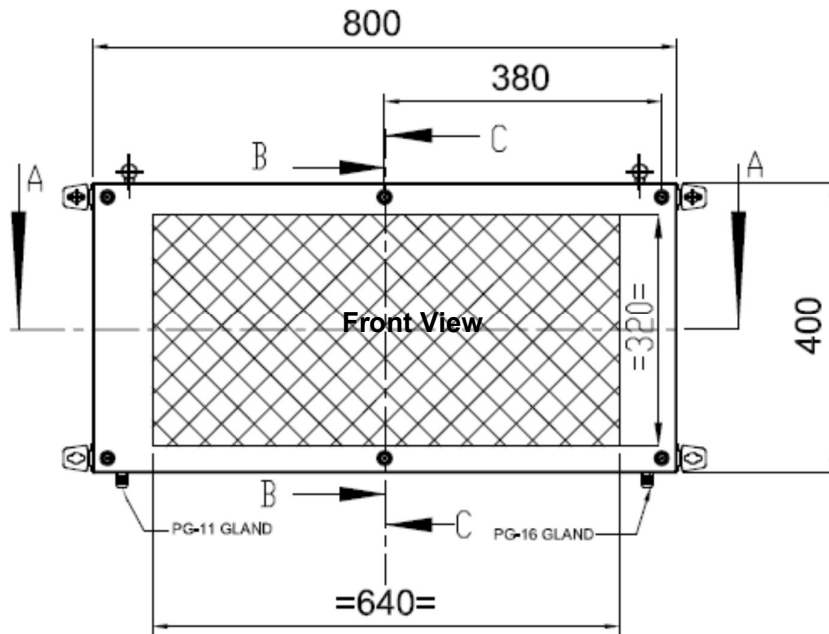
**Fig 4.10: Mounting detail for 800mm x 200mm x 120mm Enclosure**



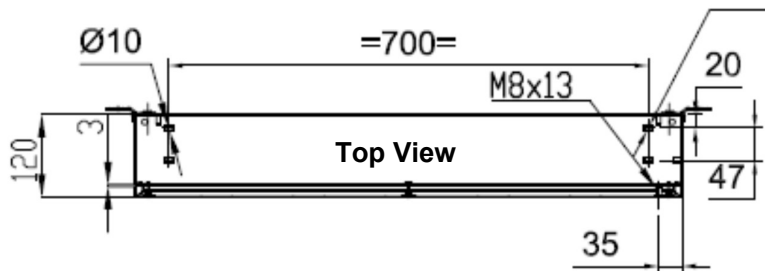
**Fig 4.11: Mounting detail for 400mm x 200mm x 120mm Enclosure**



**Fig 4.12: Mounting detail for 800mm x 400mm x 120mm Enclosure**



**Fig 4.13: Mounting detail for 800mm x 400mm x 120mm Enclosure**



## 5. TERMINAL CONNECTIONS

### 5.1 Terminal connections on IP20 Enclosures

#### 5.1.1 Terminal connection for Wall/Rack/Table Top Mount Enclosure

**Fig 5.1: Connection on Terminal plate of IP20 Wall Mount**



#### 5.1.2 Terminal connection detail for IP20 Enclosure

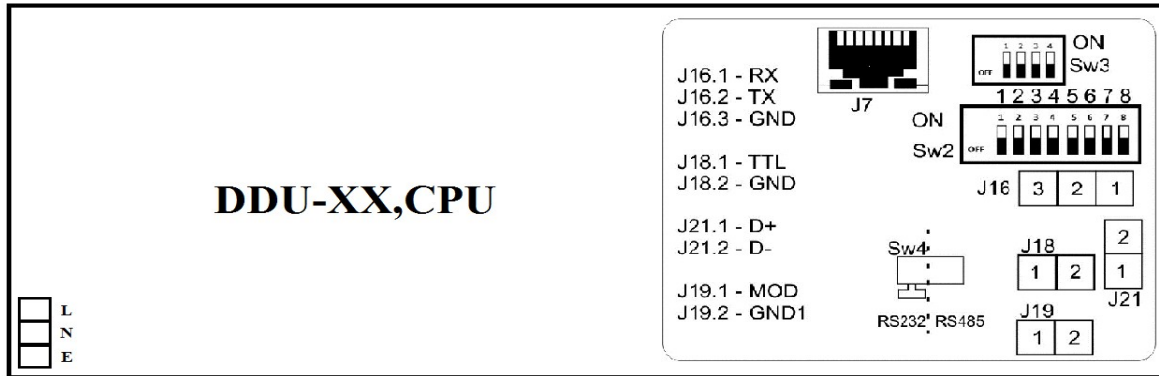
**Table 1: Terminal Connection Detail of IP20 Enclosures**

No.	Terminal Type	Description
1	RJ45 Socket for NTP	For RJ45 based Ethernet connection for NTP[Network Time Protocol]
2	DIP SWITCH for Configuration	DIP Switch SW1 & SW2 for Serial Data configuration like <ul style="list-style-type: none"> <li>Set Default switch</li> <li>Programming mode enable switch</li> </ul>
3	BNC Female Conn for IRIG-B AM	For IRIG-B12X Amplitude Modulation.
4	MSTB Conn. 2 pin for RS485	RS485 serial data input Pin -1 D+ Pin -2 D-
5	DB-9 Female Connector for RS232	FOR RS232 serial data input for <b>DDU-XX</b> Pin 1,4,6,7,8,9 – N/C Pin 2 –TX Pin 3 –RX Pin 5 – Ground
6	BNC Female Conn for IRIG-B TTL	For IRIG-B00X TTL[PWM]
7	MSTB Conn. 2 pin for Freq. IN	For Frequency Input [Voltage raw data input] [L(AC+), N(AC-)]
8	MSTB Conn. 3 pin for Power IN	Pin 1 - L Pin 2 - N Pin 3 - Earth

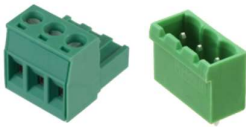



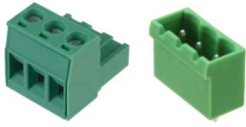

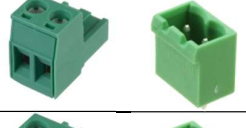

*Note:- For information related to DIP Switch selection refer Configuration section*

## 5.2 Terminal connections on IP65 Enclosures

**Fig 5.2: Connection on Terminal plate of IP65 Enclosure**



**Table 2: Terminal Connection Detail of IP65 Enclosures**

No.	Terminal Type	Description
1	MSTB Conn. 3 pin for Power IN 	Power Supply Input [L(Line), N(Neutral), E(Earth)]
2	RJ45 Socket for NTP 	For RJ45 based Ethernet connection for NTP[Network Time Protocol]
3	DIP SWITCH for Configuration SW1 SW2  	DIP Switch SW1 & SW2 for Serial Data configuration like <ul style="list-style-type: none"> <li>Baud rate</li> <li>NMEA-0183[RMC] / NGTS/ T – Format</li> <li>Date &amp; Time Display Selection</li> </ul>
4	MSTB Conn. 3 pin for RS232 	FOR RS232 serial data input – RS232 [RX] – RS232 [TX] – Ground
5	MSTB Conn. 2 pin for RS485 	FOR RS 485 serial data input – RS 485 [D+] – RS 485 [D-]
6	MSTB Conn. 2 pin for IRIG-B TTL 	For IRIG-B00X TTL[PWM]
7	MSTB Conn 2 pin for IRIG-B AM 	For IRIG-B 12X Amplitude Modulation.

**Note:** - For information related to DIP Switch selection refer Configuration section

Note:- As per Ordering code terminals will be available which terminals are not covered in ordering code will get covered by Terminal cover

### 5.3 How to connect wires

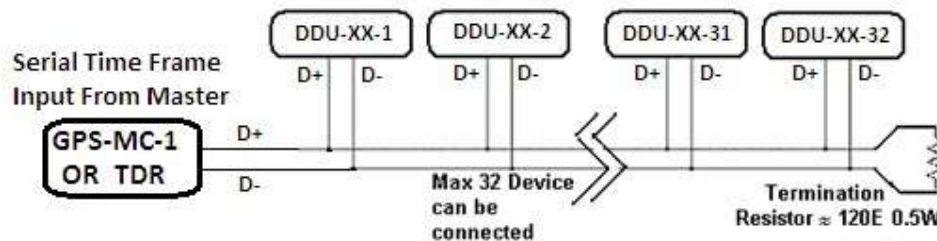
Before carrying out wiring, turn off the power and check that the cables to be connected are not alive because there is a possibility of electric shock.



#### NOTE:

- ✓ All wiring must confirm to appropriate standards of good practice and local codes and regulations. Wiring must be suitable for Voltage, Current and temperature rating of the system.
- ✓ Provide power from a single-phase instrument power supply. If there is a lot of noise in the power line, insert an insulating transformer into the primary side of the line and use a line filter on the secondary side. Do not place the primary and secondary power cables close to each other.
- ✓ Use repeater after each set of 32 instruments connected in RS-485 Communication.
- ✓ Unused terminals should not be used as jumper points as they may be internally connected, which may cause damage to the unit.
- ✓ Use >250V-1Amp Cable for Power Supply.
- ✓ Supply voltage must be below maximum voltage rating specified on the label.

**Fig 5.3: RS485 Connection Details**



- ✓ In case of RS-232 Output, external RS-232 to RS-485 Connector required, and it will be connected direct in case of RS-485 output from Master.
- ✓ For IP65 open Front cover to for cables which are going to Enclosure for passing it from Gland & than fit gland & front cover properly.



## 6. CONFIGURATION GUIDELINES

---

### 6.1 Default Configuration

- A DDU-XX ships from the factory with following configuration.

Baud Rate : 9600  
Stop Bit : 1  
Parity Bit : None

IP Address : 192.168.100.032  
Subnet mask : 255.255.255.000  
Gateway : 192.168.100.001  
Primary Server IP Address : 192.168.100.153  
Secondary Server IP Address : 192.168.100.154  
Query Interval Time [When Querying NTP Server] : 0016  
Query Request Time out : 02  
Query Retry Interval : 02  
Number of Time outs before switching Servers : 03  
Secondary Server Option for NTP : Disable

Display Type : Time Display  
Date Format : DD/MM/YY  
Time Format : Hour Time Format 24  
Leading Zeroes: Enable

IRIG-B Type : 007/127

Time Zone Offset : +05:30  
Time Zone Offset for NTP : Disable  
Time Zone Offset for IRIG-B : Disable  
Time Zone Offset for SERIAL : Disable

#### **Note:**

- For NTP Use RJ-45 cross cable when connecting DDU-XX directly with GPS Master Clock. Use RJ-45 straight cable when connect DDU-XX through switch.
- Fundamental operation mode (Display Settings) will come in affect immediately of SW change. Action of CONFIG can be switched during clock operation. No power on/off cycle is required to change these modes.
- For Time & Date Combine Display Unit, first raw is for Time & second raw is for Date by default, there will be no switch selection available for changing Time to Date or Date to Time Display.
- It is better to Power on/off DDU-XX after the completion of configurations.

### 6.2 Switch Selection for Configuration

- Basic operation of the DDU-XX series is configured via the **S2** switch banks. There are 8 switches in S1 bank and 4 switches in S2 bank.
- In IP65 Enclosure it is accessible after opening a front cover of the slave clock.
- In IP20 Enclosure it is accessible from back cover of the clock.

### 6.2.1 Function of each switch for TIME/DATE [DDU-TM/ DDU-DT] & DAY [DDU-DY] Display

**Table 3: Function of each Switch for TIME, DATE & DAY Display**

Switch Bank	Switch	Position	Function of Switches
S1	SW1	ON	Kept unused for Future use
		OFF	Kept unused for Future use
	SW2	ON	Kept unused for Future use
		OFF	Kept unused for Future use
	SW3	ON	Kept unused for Future use
		OFF	Kept unused for Future use
	SW4	ON	Kept unused for Future use
		OFF	Kept unused for Future use
	SW5	ON	Kept unused for Future use
		OFF	Kept unused for Future use
	SW6	ON	Kept unused for Future use
		OFF	Kept unused for Future use
	SW7	ON	Kept unused for Future use
		OFF	Kept unused for Future use
	SW8	ON	Kept unused for Future use
		OFF	Kept unused for Future use
S2	SW9	ON	Get DDU-XX in its default configurations.
		OFF	-
	SW10	ON	DDU-XX in programming mode.
		OFF	DDU-XX in run mode.
	SW11	ON	Kept unused for Future use
		OFF	Kept unused for Future use
	SW12	ON	Kept unused for Future use
		OFF	Kept unused for Future use

**Note:** Under DDU-XX Lock (Synchronize) condition, continuously Switch position will be read by the software & operational changes will come in effect during next minute transition. Different possible configurations of switch bank S1 & S2 are shown in Table-2. Switch bank S2 having 4 switches. SW6, SW11 & SW12 are reserved for future use. However some of settings such as SW7, SW8, SW9 & SW10 will have immediate effect.

### 6.2.2 Function of each switch for Frequency [DDU-HZ] Display with Serial Input

**Table 4: Function of each Switch for Frequency Display Serial Input**

Switch Bank	Switch	Position	Function of Switches
S1	SW1	ON	Used for Slave Device ID Selection
		OFF	
	SW2	ON	Used for Slave Device ID Selection
		OFF	
	SW3	ON	Used for Slave Device ID Selection
		OFF	
	SW4	ON	Used for Slave Device ID Selection
		OFF	
	SW5	ON	Used for Baud Rate Selection
		OFF	
	SW6	ON	Used for Baud Rate Selection
		OFF	
	SW7	ON	Kept unused for Future use
		OFF	
	SW8	ON	Kept unused for Future use
		OFF	
S2	SW9	ON	Kept unused for Future use
		OFF	
	SW10	ON	DDU-XX in programming mode.
		OFF	
	SW11	ON	Kept unused for Future use
		OFF	
	SW12	ON	Kept unused for Future use
		OFF	

**Note:** Setting Switch SW10 will have effect during Power ON only. All other used switches will have an immediate effect.

**Table 5: Baud Rate selection for Serial Input**

No	Sw5	Sw6	Communication Baud Rate
1.	OFF	OFF	19200
2.	ON	OFF	9600
3.	OFF	ON	4800
4.	ON	ON	2400

**Table 6: Device ID Configuration for DDU-Hz**

NO	Sw1	Sw2	Sw3	Sw4	DDU-Hz Device ID
1.	OFF	OFF	OFF	OFF	1
2.	ON	OFF	OFF	OFF	2
3.	OFF	ON	OFF	OFF	3
4.	ON	ON	OFF	OFF	4
5.	OFF	OFF	ON	OFF	5
6.	ON	OFF	ON	OFF	6
7.	OFF	ON	ON	OFF	7
8.	ON	ON	ON	OFF	8
9.	OFF	OFF	OFF	ON	9
10.	ON	OFF	OFF	ON	10
11.	OFF	ON	OFF	ON	11
12.	ON	ON	OFF	ON	12
13.	OFF	OFF	ON	ON	13
14.	ON	OFF	ON	ON	14
15.	OFF	ON	ON	ON	15
16.	ON	ON	ON	ON	16

**6.2.3 Function of each switch for Frequency [DDU-HZ] Display with Voltage Raw data Input**

**Table 7: Function of each Switch for Frequency Display Raw Data Input**

Switch Bank	Switch	Position	Function of Switches
S1	SW1	ON	Used for Baud Rate Selection
		OFF	
	SW2	ON	Used for Baud Rate Selection
		OFF	
	SW3	ON	Kept unused for Future use
		OFF	
	SW4	ON	Kept unused for Future use
		OFF	
SW5	ON	Kept unused for Future use	
	OFF		
SW6	ON	Kept unused for Future use	
	OFF		
SW7	ON	Kept unused for Future use	
	OFF		
SW8	ON	Kept unused for Future use	
	OFF		
S2	SW9	ON	Kept unused for Future use
		OFF	
	SW10	ON	DDU-XX in programming mode.
		OFF	DDU-XX in run mode.
SW11	ON	Kept unused for Future use	
	OFF		
SW12	ON	Kept unused for Future use	

		OFF	
--	--	-----	--

**Note:** Setting Switch SW10 will have effect during Power ON only. All other used switches will have an immediate effect.

**Table 8: Baud Rate selection for Serial Output**

No	Sw1	Sw2	Communication Baud Rate
1.	OFF	OFF	19200
2.	ON	OFF	9600
3.	OFF	ON	4800
4.	ON	ON	2400

### 6.3 Configuration Command for NTP [For Time/Date and Day & Calendar]

#### 6.3.1 For the First Time setup follow the below procedure.

1. Masibus Display Unit has default network settings as mentioned in **Section 6.1**, First connect the Display Unit direct with local computer using a **cross** cable. (Not in Network)
2. Make the computer IP 192.168.100.XXX (XXX is any value between 1 to 255)
3. Ping the Display Unit IP & response must come from it. Now follow the below commands to configure the Display Unit.

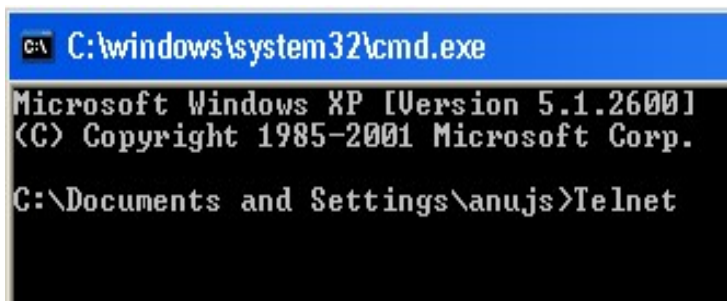
To check ping command open run window & enter **ping xxx.xxx.xxx.xxx -t** command where xxx.xxx.xxx.xxx means the IP of DDU-XX.

#### 6.3.2 Network settings using windows as TELNET client.

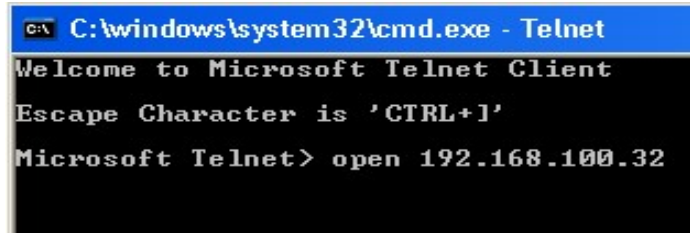
1. Open command prompt.



2. Enter Telnet and press Enter.



3. Enter “open 192.168.100.32” and press Enter.



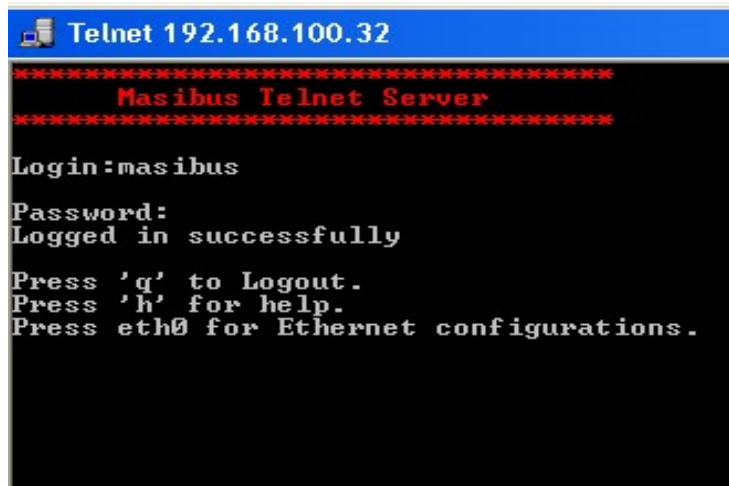
```
C:\windows\system32\cmd.exe - Telnet
Welcome to Microsoft Telnet Client
Escape Character is 'CTRL+I'
Microsoft Telnet> open 192.168.100.32
```

4. Following screen will be displayed.



```
Telnet 192.168.100.32
*****
Masibus Telnet Server
*****
Login:
```

5. Enter Login-name and press enter. Enter password and press enter. Login-name and password both are case sensitive. **Default Login- name and password both are “masibus”.**



```
Telnet 192.168.100.32
*****
Masibus Telnet Server
*****
Login:masibus
Password:
Logged in successfully
Press 'q' to Logout.
Press 'h' for help.
Press eth0 for Ethernet configurations.
```

6. IP :
- This command is used to change **IP address** of DDU-XX.
  - IP address should be entered in **xxx.xxx.xxx.xxx** form.
  - Enter new IP address and press enter. To save the new IP address Press ‘**Y**’ else press ‘**N**’. If you press **Y** new IP address will be saved and if you press **N** the previous IP address will be retained.
  - IP address of DDU-XX is 192.168.100.032 by default.

```
Telnet 192.168.100.32
*****
Masibus Telnet Server
*****
Login:masibus
Password:
Logged in successfully
Press 'q' to Logout.
Press 'h' for help.
Press eth0 for Ethernet configurations.
IP
Enter IP address:192.168.100.32
Command complete.To save changes press 'y' else press 'n':Y
Command complete
Press 'q' to Logout.
Press 'h' for help.
Press eth0 for Ethernet configurations.
```

#### 7. MASK

- This command is used to change **Subnet Mask** of DDU-XX.
- Subnet Mask should be entered in **xxx.xxx.xxx.xxx** form.
- Enter new Subnet Mask and press enter. To save the new Subnet Mask Press **'Y'** else press **'N'**. If you press **Y** new Subnet Mask will be saved and if you press **N** the previous Subnet Mask will be retained.
- Subnet Mask of DDU-XX is 255.255.255.0 by default.

```
Telnet 192.168.100.32
*****
Masibus Telnet Server
*****
Login:masibus
Password:
Logged in successfully
Press 'q' to Logout.
Press 'h' for help.
Press eth0 for Ethernet configurations.
MASK
Enter Subnet mask:255.255.255.0
Command complete.To save changes press 'y' else press 'n':Y
Command complete
Press 'q' to Logout.
Press 'h' for help.
Press eth0 for Ethernet configurations.
```

#### 8. GTY

- This command is used to change **Gateway** of DDU-XX.
- Gateway should be entered in **xxx.xxx.xxx.xxx** form.
- Enter new Gateway and press enter. To save the new Gateway. Press **'Y'** else press **'N'**. If you press **Y** new Gateway will be saved and if you press **N** the previous Gateway will be retained
- Gateway of DDU-XX is 192.168.100.1 by default.

```
Telnet 192.168.100.32
*****
Masibus Telnet Server
*****

Login:masibus
Password:
Logged in successfully

Press 'q' to Logout.
Press 'h' for help.
Press eth0 for Ethernet configurations.

GT
Enter Gateway:192.168.100.1

Command complete.To save changes press 'y' else press 'n':Y
Command complete

Press 'q' to Logout.
Press 'h' for help.
Press eth0 for Ethernet configurations.
```

9. SIP1

- This command is used to change IP address of NTP time source (**NTP Primary Server**) for DDU-XX.
- IP address should be entered in **xxx.xxx.xxx.xxx** form.
- Enter new IP address and press enter. To save the new IP address Press **'Y'** else press **'N'**. If you press **Y** new IP address will be saved and if you press **N** the previous IP address will be retained.
- IP address of NTP time source (NTP Primary server) for DDU-XX is 192.168.100.153 by default.

```
Telnet 192.168.100.32
*****
Masibus Telnet Server
*****

Login:masibus
Password:
Logged in successfully

Press 'q' to Logout.
Press 'h' for help.
Press eth0 for Ethernet configurations.

SIP1
Enter Primary NTP Server Address:192.168.100.153

Command complete.To save changes press 'y' else press 'n':Y
Command complete

Press 'q' to Logout.
Press 'h' for help.
Press eth0 for Ethernet configurations.
```

10. SIP2

- This command is used to change IP address of NTP time source (**NTP Secondary Server**) for DDU-XX.
- IP address should be entered in **xxx.xxx.xxx.xxx** form.
- Enter new IP address and press enter. To save the new IP address Press **'Y'** else press **'N'**. If you press **Y** new IP address will be saved and if you press **N** the previous IP address will be retained.
- IP address of NTP time source (NTP Secondary Server) for DDU-XX is 192.168.100.154 by default.

```
Telnet 192.168.100.32
*****
Masibus Telnet Server
*****

Login:masibus
Password:
Logged in successfully

Press 'q' to Logout.
Press 'h' for help.
Press eth0 for Ethernet configurations.

SIP2

Enter Secondary NTP Server Address:192.168.100.154

Command complete.To save changes press 'y' else press 'n':Y
Command complete

Press 'q' to Logout.
Press 'h' for help.
Press eth0 for Ethernet configurations.
```

11. NQI

- This command is used to change **NTP Query Interval Time** [When Querying NTP Servers] for DDU-XX.
- NTP Query Interval Time should be entered between 16 to 1024.
- Enter new NTP Query Interval Time and Press Enter. To save the new NTP Query Interval Time Press 'Y' else press 'N'. If you press Y new NTP Query Interval Time will be saved and if you press N the previous NTP Query Interval Time will be retained.
- NTP Query Interval Time [When Querying NTP Servers] for DDU-XX is 16 by default.

```
Telnet 192.168.100.32
*****
Masibus Telnet Server
*****

Login:masibus
Password:
Logged in successfully

Press 'q' to Logout.
Press 'h' for help.
Press eth0 for Ethernet configurations.

NQI

Enter Query Interval Time [When Querying NTP Server][Between 16 To 1024]:16

Query Interval Time Set Successfully
Command complete.To save changes press 'y' else press 'n':Y
Command complete

Press 'q' to Logout.
Press 'h' for help.
Press eth0 for Ethernet configurations.
```

12. NQT

- This command is used to change **NTP Query Request Time Out Time** for DDU-XX.
- NTP Query Request Time Out Time should be entered between 1 to 60.
- Enter new NTP Query Request Time Out Time and Press Enter. To save the new NTP Query Request Time Out Time Press 'Y' else press 'N'. If you press Y new NTP Query Request Time Out Time will be saved and if you press N the previous NTP Query Request Time Out Time will be retained.
- NTP Query Request Time Out Time for DDU-XX is 2 by default.



```
Telnet 192.168.100.32
*****
Masibus Telnet Server
*****

Login:masibus
Password:
Logged in successfully

Press 'q' to Logout.
Press 'h' for help.
Press eth0 for Ethernet configurations.

NQT
Enter Query Request Time Out[Between 1 To 60]:2

Query Request Time Out Set Successfully
Command complete.To save changes press 'y' else press 'n':Y
Command complete

Press 'q' to Logout.
Press 'h' for help.
Press eth0 for Ethernet configurations.
```

13. NQR

- This command is used to change **NTP Query Retry Time** for DDU-XX.
- NTP Query Retry Time should be entered between 1 to 60.
- Enter new NTP Query Retry Time and Press Enter. To save the new NTP Query Retry Time Press 'Y' else press 'N'. If you press Y new NTP Query Retry Time will be saved and if you press N the previous NTP Query Retry Time will be retained.
- NTP Query Retry Time for DDU-XX is 2 by default.

```
Telnet 192.168.100.32
*****
Masibus Telnet Server
*****

Login:masibus
Password:
Logged in successfully

Press 'q' to Logout.
Press 'h' for help.
Press eth0 for Ethernet configurations.

NQR
Enter Query Retry Time[Between 1 To 60]:2

Query Retry Interval Set Successfully
Command complete.To save changes press 'y' else press 'n':Y
Command complete

Press 'q' to Logout.
Press 'h' for help.
Press eth0 for Ethernet configurations.
```

14. NOT

- This command is used to change **NTP Number of time out counts** before switching servers for DDU-XX.
- Number of time out counts before switching servers me should be entered between 1 to 15.
- Enter new Number of time out counts before switching servers and Press Enter. To save the new Number of time out counts before switching servers Press 'Y' else press 'N'. If you press Y new

Number of time out counts before switching servers will be saved and if you press **N** the previous Number of time out counts before switching servers will be retained.

- Number of time out counts before switching servers for DDU-XX is 3 by default.

#### 15. SNS

- This command is used to enable or Disable **Secondary Server Option for NTP** for DDU-XX.
- The Selection of Secondary NTP server enables or Disable by Pressing '**E**' or '**D**' followed by enter Key respectively.
- To save the Selection of Secondary Server Option Press '**Y**' else press '**N**'. If you press **Y** new Selection of Secondary Server option will be saved and if you press **N** the previous Selection of Secondary Server will be retained.
- By Default Secondary server Option for NTP is Disable.

```
Telnet 192.168.100.32
*****
Masibus Telnet Server
*****
Login:masibus
Password:
Logged in successfully
Press 'q' to Logout.
Press 'h' for help.
Press eth0 for Ethernet configurations.
SNS
Press E To Enable Secondary NTP Server else Press D:e
Secondary NTP server option Set Successfully
Command complete.
To save changes press 'Y' else press 'N':Y
Command complete
Press 'q' to Logout.
Press 'h' for help.
Press eth0 for Ethernet configurations.
```

#### 16. Z

- This command is used to Set **Time Zone Offset Configuration** for DDU-XX.
- By entering "**Z**" You will enter in Time Zone Offset Configuration.

```
Telnet 192.168.100.32
*****
Masibus Telnet Server
*****
Login:masibus
Password:
Logged in successfully
Press 'q' to Logout.
Press 'h' for help.
Press eth0 for Ethernet configurations.
Z
Time Zone Offset Configuration
Command : Function
1 : View Time Zone Configuration Parameters
2 : Enter Time Zone Offset
3 : Enable Time Zone Offset For NTP
4 : Enable Time Zone Offset For IRIG-B
5 : Enable Time Zone Offset For SERIAL
```

#### 16.1 “Z” “1” Command:

- By Press “1” enter in “Z” menu for View Time Zone Configuration, you will get Details of Current Time Zone Settings.

```
Telnet 192.168.100.32
Masibus Telnet Server
Password:
Logged in successfully
Press 'q' to Logout.
Press 'h' for help.
Press eth0 for Ethernet configurations.
Z
Time Zone Offset Configuration
Command : Function
1 : View Time Zone Configuration Parameters
2 : Enter Time Zone Offset
3 : Enable Time Zone Offset For NTP
4 : Enable Time Zone Offset For IRIG-B
5 : Enable Time Zone Offset For SERIAL
1
Time Zone Offset : +05:30
Time Zone Offset For NTP : Disable
Time Zone Offset For IRIG-B : Disable
Time Zone Offset For SERIAL : Disable
```

#### 16.2 “Z” “2” Command:

- By Press “2” enter in “Z” menu for to Set Time Zone offset.
- Enter Standard Time Zone in +HH:MM or -HH:MM format, any else than Standard time zone will give invalid entry message.
- To save the Selection of Time Zone offset Press ‘Y’ else press ‘N’. If you press Y new Selection of Time Zone offset will be saved and if you press N the previous Selection of Time Zone offset will be retained.
- By Default Time Zone Offset is +05:30.

```
Telnet 192.168.100.32
Masibus Telnet Server
Login:masibus
Password:
Logged in successfully
Press 'q' to Logout.
Press 'h' for help.
Press eth0 for Ethernet configurations.
Z
Time Zone Offset Configuration
Command : Function
1 : View Time Zone Configuration Parameters
2 : Enter Time Zone Offset
3 : Enable Time Zone Offset For NTP
4 : Enable Time Zone Offset For IRIG-B
5 : Enable Time Zone Offset For SERIAL
2
Time Zone Offset Configuration
Enter Time Zone Offset[+HH:MM or -HH:MM]:+05:30
Time zone offset set successfully
Command complete.
To save changes press 'Y' else press 'N':Y
Command complete
Press 'q' to Logout.
Press 'h' for help.
Press eth0 for Ethernet configurations.
```

#### 16.2 “Z” “3” Command:

- By Press “3” enter in “Z” menu for to enable Time Zone offset for NTP input.
- Enter “0” followed by Enter, it will disable Time zone offset for NTP.
- Enter “1” followed by Enter, it will enable Time zone offset for NTP.

- To save the Selection of Time Zone offset for NTP input Press 'Y' else press 'N'. If you press Y new Selection of Time Zone offset for NTP input will be saved and if you press N the previous Selection of Time Zone offset for NTP input will be retained.
- By default it is Disable for NTP.

```
Telnet 192.168.100.32
*****
Masibus Telnet Server
*****
Login:masibus
Password:
Logged in successfully
Press 'q' to Logout.
Press 'h' for help.
Press eth0 for Ethernet configurations.

Z
Time Zone Offset Configuration
Command : Function
1 : View Time Zone Configuration Parameters
2 : Enter Time Zone Offset
3 : Enable Time Zone Offset For NTP
4 : Enable Time Zone Offset For IRIG-B
5 : Enable Time Zone Offset For SERIAL

3
Time Zone Offset Configuration
Time Zone Offset For NTP
Command : Function
0 : Time Zone Offset Disable
1 : Time Zone Offset Enable

1
NTP Time zone offset set successfully
Command complete.
To save changes press 'Y' else press 'N':Y
Command complete
```

16.3 "Z" "4" Command:

- By Press "4" enter in "Z" menu for to enable Time Zone offset for IRIG-B input.
- Enter "0" followed by Enter, it will disable Time Zone offset for IRIG-B input.
- Enter "1" followed by Enter, it will enable Time Zone offset for IRIG-B input.
- To save the Selection of Time Zone offset for NTP input Press 'Y' else press 'N'. If you press Y new Selection of Time Zone offset for IRIG-B input will be saved and if you press N the previous Selection of Time Zone offset for IRIG-B input will be retained.
- By default it is disable for IRIG-B.

```
Telnet 192.168.100.32
*****
Masibus Telnet Server
*****
Login:masibus
Password:
Logged in successfully
Press 'q' to Logout.
Press 'h' for help.
Press eth0 for Ethernet configurations.

Z
Time Zone Offset Configuration
Command : Function
1 : View Time Zone Configuration Parameters
2 : Enter Time Zone Offset
3 : Enable Time Zone Offset For NTP
4 : Enable Time Zone Offset For IRIG-B
5 : Enable Time Zone Offset For SERIAL

4
Time Zone Offset Configuration
Time Zone Offset For IRIG-B
Command : Function
0 : Time Zone Offset Disable
1 : Time Zone Offset Enable

1
IRIGB Time zone offset set successfully
Command complete.
To save changes press 'Y' else press 'N':Y
Command complete
```

### 16.3 “Z” “5” Command:

- By Press “5” enter in “Z” menu for to enable Time Zone offset for SERIAL input.
- Enter “0” followed by Enter, it will disable Time Zone offset for SERIAL input.
- Enter “1” followed by Enter, it will enable Time Zone offset for SERIAL input.
- To save the Selection of Time Zone offset for SERIAL input Press ‘Y’ else press ‘N’. If you press Y new Selection of Time Zone offset for SERIAL input will be saved and if you press N the previous Selection of Time Zone offset for SERIAL input will be retained.
- By default it is disable for SERIAL.

```
Telnet 192.168.100.32
*****
Masibus Telnet Server
*****
Login:masibus
Password:
Logged in successfully
Press 'q' to Logout.
Press 'h' for help.
Press eth0 for Ethernet configurations.
Z
Time Zone Offset Configuration
Command : Function
1 : View Time Zone Configuration Parameters
2 : Enter Time Zone Offset
3 : Enable Time Zone Offset For NTP
4 : Enable Time Zone Offset For IRIG-B
5 : Enable Time Zone Offset For SERIAL
5
Time Zone Offset Configuration
Time Zone Offset For SERIAL
Command : Function
0 : Time Zone Offset Disable
1 : Time Zone Offset Enable
1
SERIAL Time zone offset set successfully
Command complete.
To save changes press 'Y' else press 'N':Y
Command complete
```

### 17. MT

- This command is used to Set **Manual Time Setting** for DDU-XX.
- By entering “MT” You will enter in **Manual Time Setting** Configuration.
- Enter Time and Date in HH:MM:SS,DD/MM/YY mode after it will give conformation.

```
Telnet 192.168.100.32
*****
Masibus Telnet Server
*****
Login:masibus
Password:
Logged in successfully
Press 'q' to Logout.
Press 'h' for help.
Press eth0 for Ethernet configurations.
MT
Manual Time And Date Setting
Enter Time and Date [HH:MM:SS,DD/MM/YY]:10:30:30,27/09/16
Manual Time and Date set successfully
Command complete.
To save changes press 'Y' else press 'N':Y
Command complete
Press 'q' to Logout.
Press 'h' for help.
Press eth0 for Ethernet configurations.
```

18. P

- The user is allowed to change telnet password. The command for changing the password is: P (**password**).
- Then enter new password and press enter. To save the new password press 'Y' else press 'N'. If you press Y new password will be saved and if you press N the previous password will be retained.
- The default password is 'masibus'.
- Remember that the password should not exceed 10 characters. If you try to keep a password that has more than 10 characters, the system will show an error "Invalid Entry" and the previous password will be retained.

```
Telnet 192.168.100.32
*****
Masibus Telnet Server
*****
Login:masibus
Password:
Logged in successfully
Press 'q' to Logout.
Press 'h' for help.
Press eth0 for Ethernet configurations.
P
Enter new Telnet Password:
Password changed.
Command complete.
To save changes press 'Y' else press 'N':Y
Command complete
Press 'q' to Logout.
Press 'h' for help.
Press eth0 for Ethernet configurations.
```

19. U

- The user is allowed to change telnet Login name. The command for changing the Login name is: 'U'.
- Then enter new Login name and press enter. To save the new Login name. Press 'Y' else press 'N'. If you press Y new Login name will be saved and if you press N the previous Login name will be retained.
- The default Login name is 'masibus'.
- Remember that the Login name should not exceed 10 characters. If you try to keep a Login name that has more than 10 characters, the system will show an error "Invalid Entry" and the previous Login name will be retained.

```
Telnet 192.168.100.32
*****
Masibus Telnet Server
*****
Login:masibus
Password:
Logged in successfully
Press 'q' to Logout.
Press 'h' for help.
Press eth0 for Ethernet configurations.
U
Enter new Telnet Username:
Username changed.
Command complete.To save changes press 'y' else press 'n':Y
Command complete
Press 'q' to Logout.
Press 'h' for help.
Press eth0 for Ethernet configurations.
```

20. H

This **HELP** command is used to see different commands and their functions.

```
Telnet 192.168.100.32
*****
Masibus Telnet Server
*****
Login:masibus
Password:
Logged in successfully
Press 'q' to Logout.
Press 'h' for help.
Press eth0 for Ethernet configurations.
H
-----
COMMAND  FUNCTION
-----
IP        IP address
MASK      SUBNET MASK
GTY       GATEWAY
SIP1      Primary NTP Server Address
SIP2      Secondary NTP Server Address
NQI       Query Interval Time[When Querying NTP Servers]
NQI       Query Request Time Out
NQR       Query Retry Interval
NOT       Number Of Time Outs Before switching Servers
SNS       Secondary Server option for NTP
Z         Time Zone Offset Configuration
MT        Manual Time And Date Setting
P         Password
U         User name
```

21. ETH0 [ETH(Zero)]

This command is used to see present NTP configurations.

```
Telnet 192.168.100.32
*****
Masibus Telnet Server
*****
Login:masibus
Password:
Logged in successfully
Press 'q' to Logout.
Press 'h' for help.
Press eth0 for Ethernet configurations.
ETH0
IP Address           :192.168.100.032
Subnet Mask          :255.255.255.000
Gateway              :192.168.100.001
Primary NTP Server Address :192.168.100.153
Secondary NTP Server Address :192.168.100.154
NTP Query Interval Time :0016
NTP Query Time Out    :002
NTP Query Retry Interval :002
Number Of Retry Before Switching NTP Server:003
Secondary Server option for NTP :Disable
```

22. Q

This command is used to close Telnet session.

### 6.3.3 Important Points for Telnet Configuration

- Digital Display Unit's Telnet Server has timeout period of 5 minutes. If you do not press any character till 5 minutes, the session will be automatically closed with a message of Timeout, Session Closed.
- Commands are case insensitive.
- If Display Unit Telnet server is open at that time Display Unit will not synchronize with the NTP Time Source.
- Display Unit operates in NTP client mode.

## 6.4 Serial Configuration [For Time/Date and Day & Calendar]

**DDU-XX** offers facility to the users for configuring communication parameters of serial port, Display Format Selection, Time Zone Selection, Ethernet Configuration, Manual Time Set, IRIG-B Format Selection, Set Default Parameter and View Current Settings.

- The communication parameters include baud rate, number of stop bits and parity.
- In Ethernet Configuration, User can set, IP, MASK, GATEWAY, SUBNET, Primary Server IP, Secondary Server IP, NTP Query Interval Time [When Querying NTP Server] , Query Request Time Out , Query Retry Interval , Number of Time outs Before switching Servers, Secondary Server Option For NTP.
- User Can Set Manual Time if no availability of Time Inputs.
- The user is free to choose Time Display, Date Display and Both in Alternate Time/Date Display.
- User Can Select IRIG-B Input Type IRIG-B 002/122 or IRIG-B 007/127.
- User can set any Standard Time Zone Offset, in any Input like NTP, IRIG-B, and Serial.
- The user can enter the time offset of the time zone, where the unit is to be installed.
- Users can set Default all Configuration Parameter and View Current Configuration Parameter using Serial Configuration.
- User Can Check Current Synchronization Status of DDU Configuration Parameter
- In Day Display Unit, there will be no availability of display configuration.

### 6.4.1 For the First Time setup follow the below procedure.

Configuration requires a standard 9-way D-type RS-232 cable / standard 2-way twisted pair RS-485 cable with standard RS485 to RS232 Converter and standard communication software in the PC, such as HyperTerminal. HyperTerminal is available in every Windows based PC on the link shown in figure 6.4.1.

**Note:** - RS485 to RS232 converter is not supplied along with the product,  
In place of RS485 to RS232 converter, RS485 to USB converter also can be used.

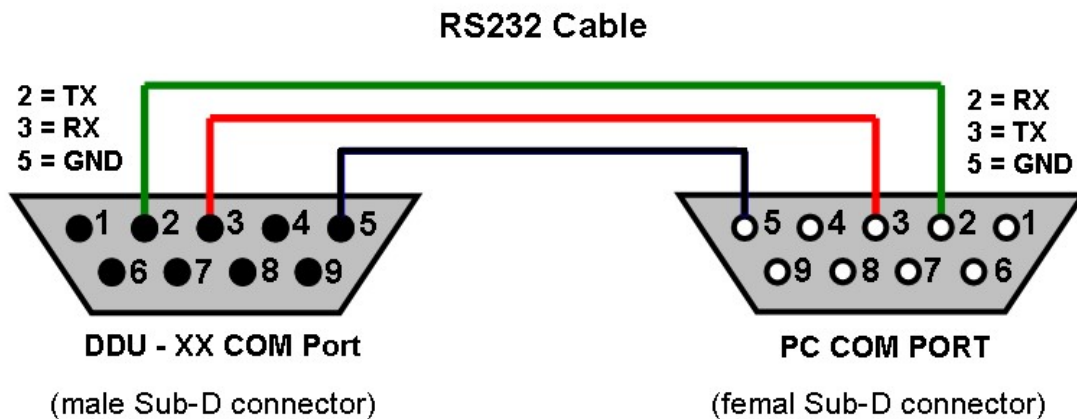


**Fig 6.4.1.0: Hyper Terminal**



The cable requirement for the DDU-XX configuration is shown in figure 6.4.2. Connect one end of the cable to the COM Port of DDU-XX and other end to an available serial port on your local PC. Open the HyperTerminal and start new connection on COMx of your PC. (x can be any available serial RS232 port number) In using HyperTerminal, it is recommended to select File\Properties\Settings and set Emulation to ANSI, to avoid auto-detect making unwanted changes to the settings.

**Fig 6.4.1.1: RS232 Cable Connection**



The port settings in HyperTerminal and the COM port of the DDU-XX must match each other for fruitful communication. The default settings of COM port of the DDU-XX are 9600 baud, 8, N, 1. The settings of the HyperTerminal must be set same as COM port of the DDU-XX to initialize the communication. This is shown in figure 6.4.3. In order to configure the settings, Please Follow Below steps on the HyperTerminal.

- Step 1: Open Hyper Terminal follow figure 6.4.1
- Step 2: Hyper Terminal Name
- Step 3: Select Local PC COM Port, in which you wish to connect DDU-XX.

- Step 4: Select Baud Rate, Parity Bit and Stop Bit.

**Fig 6.4.1.2: Configuration of Hyper terminal**

COM: 9600 - N - 8 - 1

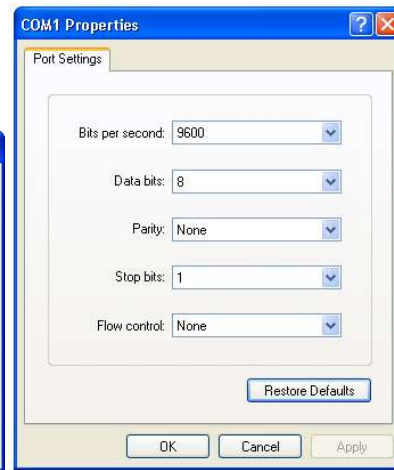
Step 2:



Step 3:



Step 4:



## 6.4.2 CONFIGURATION COMMANDS AND PASSWORD

### 6.4.2.1 "CONFIG" command and Password:

- Enter "CONFIG" followed by Enter.
- You will get Password Page as shown in figure 6.4.2.1.1

**Fig 6.4.2.1.1: CONFIG**

```
CONFIG
Enter Password :_
```

- Password is user defined and by default password is "MASIBUS". User can change this password by logging in by entering correct password. Enter Correct Password "MASIBUS", if password is matched it will give conformation of password OK and ask to enter command to Configure parameter as shown in figure 6.4.2.1.2

**Fig 6.4.2.1.2: CONFIG and Password Ok**

```
CONFIG
Enter Password :*****
Password OK
Enter Command To Configure Parameter

Press H For Help Menu
Press Q To Exit
```

- If you enter a wrong password it will give message of access denied and ask to enter "CONFIG".

**Fig 6.4.2.1.3: Wrong Password**

```
CONFIG
Enter Password :****
Access Denied
Enter 'CONFIG' To Enter in Configuration Mode
```

**6.4.2.2 "H" and "Q" command:**

- By Entering Correct password it will show figure 6.4.2.1.2 and in this page it will ask to press "H" for Help Menu and "Q" for Exit.
- Press "H" followed by Enter you will get below image.

**Fig 6.4.2.2.1: H for Help Menu**

```
H
*****
                        DDU-XX
*****
Commands :   Function
  S       :   Serial Configuration
  E       :   Ethernet Configuration
  M       :   Manual Time & Date Setting
  D       :   Display Configuration
  I       :   IRIG-B Frame Format Configuration
  Z       :   Time Zone Offset Configuration
  PWD     :   Change Password
  SD      :   Set Default All Parameters
  L       :   List Of Current Parameters
  CS      :   Current Sync Status

Enter Commands To Configure Parameters
Press Q To Exit
```

- Press "Q" followed by Enter you will get below image.

**Fig 6.4.2.2.1: Q for Exit**

```
Q
You Have Exit From Configuration Mode
_
```

#### 6.4.2.3 “S” command:

- Press “S” for Serial Configuration:
- By entering “S” followed by Enter you will get below image.

**Fig 6.4.2.3.1: S Menu**

```
S

Serial Configuration
Command  :  Function
  1      :  Baud Rate
  2      :  Stop Bit
  3      :  Parity

Press H For Help Menu
Press Q To Exit

_
```

#### 6.4.2.3.1 “S” “1” commands:

- If you want to change Baud Rate of Serial Port , Enter “1” followed by Enter , then it will show figure 6.4.2.3.2:
- Press Command between 1 to 6, according below image to set your baud rate.
- If you want to set 115200 baud rate then press 6, by pressing 6 followed by Enter, it will set baud rate of 115200 and Communication must stopped.
- If your Device baud rate and Hyper terminal Baud rate is not same , then hyper terminal stop the working you have to again configure the Hyper terminal baud rate.
- As shown in figure 6.4.2.3.3, you have to disconnect the hyper terminal and then from File->Properties, change Baud rate accordingly.

**Fig 6.4.2.3.2: Baud rate menu**

```
1

Serial Configuration
Baud Rate Selection
Command  :  Baud Rate
  1      :  4800
  2      :  9600
  3      :  19200
  4      :  38400
  5      :  57600
  6      :  115200

Press H For Help Menu
Press Q To Exit
```

**Fig 6.4.2.3.3: Hyper terminal Disconnect**



**6.4.2.3.2 “S” “2” commands:**

- If you want to change Stop Bit of Serial Port , Enter “2” followed by Enter in “S” menu, then it will show figure 6.4.2.3.4:

**Fig 6.4.2.3.4: Stop bit**

```
Serial Configuration
Stop Bit Selection
Command      :   Function
   1         :   1 Stop Bit
   2         :   2 Stop Bit

Press H For Help Menu
Press Q To Exit
```

- Press Command 1 for 1 Stop bit and Press 2 for 2 stop bit.
- If you want to set 1 Stop Bit then press 1, followed by Enter, it will set stop bit 1.
- As shown in figure 6.4.2.3.3, you have to disconnect the hyper terminal and then from File->Properties, change Stop bit accordingly.

**6.4.2.3.2 “S” “3” commands:**

- If you want to change Parity Bit of Serial Port , Enter “3” followed by Enter in “S” menu, then it will show figure 6.4.2.3.5:

**Fig 6.4.2.3.5: parity bit**

```
3  
  
Serial Configuration  
Parity Selection  
Command : Function  
  1      : Even Parity  
  2      : Odd Parity  
  3      : None Parity  
  
Press H For Help Menu  
Press Q To Exit
```

- Press Command between 1 to 3, according to what you have to set the Parity Bit.
- If you want to set Even Parity Bit then press 1, followed by Enter, it will set Parity Bit to Even and Communication must stopped.
- As shown in figure 6.4.2.3.3, you have to disconnect the hyper terminal and then from File->Properties, change Parity Bit according to your set value.

#### 6.4.2.4 “E” command:

- Press “E” for Ethernet Configuration:
- By entering “E” followed by Enter you will get figure 6.4.2.4.1.

**Fig 6.4.2.4.1: Ethernet Configuration**

```
E  
  
Ethernet Configuration  
Command : Function  
  1      : View Current Ethernet Parameters  
  2      : Set IP Address  
  3      : Set Subnet Mask  
  4      : Set Gateway  
  5      : Set Primary Server IP Address  
  6      : Set Secondary Server IP Address  
  7      : Query Interval Time [When Querying NTP Server]  
  8      : Query Request Time out  
  9      : Query Retry Interval  
 10     : Number of Time outs Before switching Servers  
 11     : Secondary Server option for NTP  
 12     : Set Default Ethernet Parameters  
  
Press H For Help Menu  
Press Q To Exit
```

#### 6.4.2.4.1 “E” “1” commands:

- If you want to view current Ethernet Parameter, Enter “1” followed by Enter in “E” menu, then it will show figure 6.4.2.4.2.

**Fig 6.4.2.4.2: View Current Parameter**

```
1

List Of Ethernet Parameters

IP Address           :192.168.100.032
Subnetmask           :255.255.255.000
Gateway              :192.168.100.001
Primary Server IP Address :192.168.100.153
Secondary Server IP Address :192.168.100.154
Query Interval Time[When Querying NTP Server] :0016
Query Request Time out :02
Query Retry Interval :02
Number of Time outs Before switching Servers :03
Secondary Server option for NTP :Disable

Press H For Help Menu
Press Q To Exit
```

#### 6.4.2.4.2 “E” “2” commands:

- If you want to set IP Address of DDU-XX device, Enter “2” followed by Enter in “E” menu, then it will show figure 6.4.2.4.3 and Ask for to Enter IP Address in XXX.XXX.XXX.XXX format.
- After Entering IP Address, it will give conformation as shown in figure 6.4.2.4.4 and if you enter wrong address it will give message of invalid data.
- By Default IP Address is 192.168.100.32

**Fig 6.4.2.4.3: Enter IP**

```
2
Ethernet Configuration
Press H For Help Menu
Press Q To Exit
Enter IP Address[XXX.XXX.XXX.XXX]:_
```

**Fig 6.4.2.4.4: IP SET**

```
2
Ethernet Configuration
Press H For Help Menu
Press Q To Exit
Enter IP Address[XXX.XXX.XXX.XXX]:192.168.100.32
IP Address Stored Successfully
Press H For Help Menu
Press Q To Exit
```

**6.4.2.4.3 “E” “3” commands:**

- If you want to set IP Address of Subnet MASK of DDU-XX device, Enter “3” followed by Enter in “E” menu, then it will show figure 6.4.2.4.5 and Ask for to Enter IP Address of Subnet MASK in XXX.XXX.XXX.XXX format.
- After Entering IP Address of Subnet MASK, it will give conformation as shown in figure 6.4.2.4.6 and if you enter wrong address it will give message of invalid data.
- By Default IP Address of Subnet MASK is 255.255.255.0

**Fig 6.4.2.4.5: ENTER MASK**

```
3
Ethernet Configuration
Press H For Help Menu
Press Q To Exit
Enter Subnet Mask[XXX.XXX.XXX.XXX]:
```



**Fig 6.4.2.4.6: MASK SET**

```
3
Ethernet Configuration
Press H For Help Menu
Press Q To Exit

Enter Subnet Mask[XXX.XXX.XXX.XXX]:255.255.255.0

Subnet Mask Stored Successfully

Press H For Help Menu
Press Q To Exit
```

**6.4.2.4.4 “E” “4” commands:**

- If you want to set IP Address of Gateway of DDU-XX device, Enter “4” followed by Enter in “E” menu, then it will show figure 6.4.2.4.7 and Ask for to Enter IP Address of Gateway in XXX.XXX.XXX.XXX format.
- After Entering IP Address of Gateway, it will give conformation as shown in figure 6.4.2.4.8 and if you enter wrong address it will give message of invalid data.
- By Default IP Address of Gateway is 192.168.100.1

**Fig 6.4.2.4.7: ENTER GATEWAY**

```
4
Ethernet Configuration
Press H For Help Menu
Press Q To Exit

Enter Gateway [XXX.XXX.XXX.XXX]:_
```

**Fig 6.4.2.4.8: GATEWAY SET**

```
4
Ethernet Configuration
Press H For Help Menu
Press Q To Exit

Enter Gateway [XXX.XXX.XXX.XXX]:192.168.100.1

Gateway Stored Successfully

Press H For Help Menu
Press Q To Exit
```

**6.4.2.4.5 “E” “5” commands:**

- If you want to set IP Address of Primary Server of DDU-XX device, Enter “5” followed by Enter in “E” menu, then it will show figure 6.4.2.4.9 and Ask for to Enter IP Address of Primary Server in XXX.XXX.XXX.XXX format.
- After Entering IP Address of Primary Server, it will give conformation as shown in figure 6.4.2.4.10 and if you enter wrong address it will give message of invalid data.
- By Default IP Address of Primary Server is 192.168.100.153

**Fig 6.4.2.4.9: ENTER Primary Server**

```
5
Ethernet Configuration
Press H For Help Menu
Press Q To Exit
Enter Primary Server IP Address[XXX.XXX.XXX.XXX]:
```

**Fig 6.4.2.4.10: Primary Server Set**

```
5
Ethernet Configuration
Press H For Help Menu
Press Q To Exit
Enter Primary Server IP Address[XXX.XXX.XXX.XXX]:192.168.100.153
Primary Server IP Address Stored Successfully
Press H For Help Menu
Press Q To Exit
```

**6.4.2.4.6 “E” “6” commands:**

- If you want to set IP Address of Secondary Server of NTP in DDU-XX device, Enter “6” followed by Enter in “E” menu, then it will show figure 6.4.2.4.11 and Ask for to Enter IP Address of Primary Server in XXX.XXX.XXX.XXX format.
- After Entering IP Address of Secondary Server, it will give conformation as shown in figure 6.4.2.4.12 and if you enter wrong address it will give message of invalid data.
- By Default IP Address of Secondary Server is 192.168.100.154

**Fig 6.4.2.4.11: ENTER Secondary Server**

```
6
Ethernet Configuration
Press H For Help Menu
Press Q To Exit
Enter Secondary Server IP Address [XXX.XXX.XXX.XXX]:_
```

**Fig 6.4.2.4.12: Secondary Server Set**

```
6
Ethernet Configuration
Press H For Help Menu
Press Q To Exit

Enter Secondary Server IP Address [XXX.XXX.XXX.XXX]:192.168.100.154

Secondary Server IP Address Stored Successfully

Press H For Help Menu
Press Q To Exit
```

**6.4.2.4.7 “E” “7” commands:**

- If you want to set Query Interval Time [When Querying NTP Server] of DDU-XX device, Enter “7” followed by Enter in “E” menu, then it will show figure 6.4.2.4.13 and Ask for to Query Interval Time between 16 to 1024.
- After Entering Query Interval Time, it will give conformation as shown in figure 6.4.2.4.14 and if you enter wrong value it will give message of invalid data.
- By Default Query Interval Time is 16.

**Fig 6.4.2.4.13: ENTER Query Interval Time**

```
7
Ethernet Configuration
Press H For Help Menu
Press Q To Exit

Enter Query Interval Time [When Querying NTP Server][Between 16 To 1024]:
```

**Fig 6.4.2.4.14: Query Interval Time Set**

```
7
Ethernet Configuration
Press H For Help Menu
Press Q To Exit

Enter Query Interval Time [When Querying NTP Server][Between 16 To 1024]:16

Query Interval Time Set Successfully

Press H For Help Menu
Press Q To Exit
```

**6.4.2.4.8 “E” “8” commands:**

- If you want to set Query Request Time Out in DDU-XX device, Enter “8” followed by Enter in “E” menu, then it will show figure 6.4.2.4.15 and Ask for to Enter set Query Request Time Out between 1 to 60.
- After Entering set Query Request Time Out, it will give conformation as shown in figure 6.4.2.4.16 and if you enter wrong address it will give message of invalid data.
- By Default set Query Request Time Out is 2

**Fig 6.4.2.4.15: Enter Query Request Time Out**

```
8
Ethernet Configuration
Press H For Help Menu
Press Q To Exit
Enter Query Request Time Out[Between 1 To 60]:
```

**Fig 6.4.2.4.15: Enter Query Request Time Out**

```
8
Ethernet Configuration
Press H For Help Menu
Press Q To Exit
Enter Query Request Time Out[Between 1 To 60]:2
Query Request Time Out Set Successfully
Press H For Help Menu
Press Q To Exit
```

**6.4.2.4.9 “E” “9” commands:**

- If you want to set Query Retry Time in DDU-XX device, Enter “9” followed by Enter in “E” menu, then it will show figure 6.4.2.4.17 and Ask for to Enter set Query Retry Time between 1 to 60.
- After Entering set Query Retry Time, it will give conformation as shown in figure 6.4.2.4.18 and if you enter wrong address it will give message of invalid data.
- By Default Query Retry Time is 2

**Fig 6.4.2.4.17: Enter Query Retry Time**

```
9
Ethernet Configuration
Press H For Help Menu
Press Q To Exit
Enter Query Retry Time[Between 1 To 60]:
```

**Fig 6.4.2.4.18: Query Retry Time Set**

```
9
Ethernet Configuration
Press H For Help Menu
Press Q To Exit
Enter Query Retry Time[Between 1 To 60]:2
Query Retry Time Set Successfully
Press H For Help Menu
Press Q To Exit
```

#### 6.4.2.4.10 “E” “10” commands:

- If you want to set Number of time out counts before switching servers in DDU-XX device, Enter “10” followed by Enter in “E” menu, then it will show figure 6.4.2.4.19 and Ask for to Enter to set Number of time out counts between 1 to 60.
- After Entering set Number of time out counts, it will give conformation as shown in figure 6.4.2.4.20 and if you enter wrong address it will give message of invalid data.
- By Default Number of time out counts is 3

**Fig 6.4.2.4.19: Enter Number of Time Out Counts**

```
10
Ethernet Configuration
Press H For Help Menu
Press Q To Exit
Enter Number Of Time Out Counts Before Switching Servers[Between 1 To 15]:
```

**Fig 6.4.2.4.20: Number of Time Out Counts set**

```
10
Ethernet Configuration
Press H For Help Menu
Press Q To Exit
Enter Number Of Time Out Counts Before Switching Servers[Between 1 To 15]:3
Number of Time Out Counts Set Successfully
Press H For Help Menu
Press Q To Exit
```

#### 6.4.2.4.11 “E” “11” commands:

- If you want Enable or Disable Secondary Server Option for NTP before switching servers in DDU-XX device, Enter “11” followed by Enter in “E” menu, then it will show figure 6.4.2.4.21 and Ask for to Enable or Disable Secondary Server Option for NTP.
- After Enable or Disable Secondary Server Option for NTP, it will give conformation as shown in figure 6.4.2.4.22 and if you enter wrong value it will give message of invalid data.
- By Secondary Server Option for NTP is Disable.

**Fig 6.4.2.4.21: Secondary Server Option Selection**

```
11
Ethernet Configuration
Press H For Help Menu
Press Q To Exit
Secondary Server option for NTP
Command : Function
  0      : Disable
  1      : Enable
Press H For Help Menu
Press Q To Exit
```

**Fig 6.4.2.4.22: Secondary Server Option Set**

```
1
Secondary NTP Server Enabled
Press H For Help Menu
Press Q To Exit
```

**6.4.2.4.12 “E” “12” commands:**

- If you want to set Default all Ethernet Parameter, Press “12” followed by enter in “E” menu, it will set default all parameter.

**6.4.2.5 “M” command:**

- Press “M” for Manual Time Setting:
- By entering “M” followed by Enter you will get figure 6.4.2.5.1.

**Fig 6.4.2.5.1: Enter Manual Time & Date Set**

```
M
Manual Time And Date Setting
Press H For Help Menu
Press Q To Exit
Enter Time and Date [HH:MM:SS,DD/MM/YY]:
```

- Enter Time and Date in HH:MM:SS,DD/MM/YY mode after it will give conformation as shown in below image.

**Fig 6.4.2.5.2: Manual Time & Date Set**

```
M
Manual Time And Date Setting
Press H For Help Menu
Press Q To Exit
Enter Time and Date [HH:MM:SS,DD/MM/YY]:01:01:00,11/11/14
Manual Time And Date Set Successfully
Press H For Help Menu
Press Q To Exit
```

#### 6.4.2.6 “D” command:

##### For Time/Date Display:

- Press “D” for Display Configuration:
- By entering “D” followed by Enter you will get figure 6.4.2.6.1.

**Fig 6.4.2.6.1: Display Setting**

```
D
Display Configuration
Command : Function
  1      : Time/Date Display selection
  2      : Date Format
  3      : Time Format
  4      : Leading Zeroes

Press H For Help Menu
Press Q To Exit
```

##### 6.4.2.6.1 “D” ”1” command:

- Press “1” followed by enter in “D” menu for Time /Date Display selection :
- By entering “1” followed by Enter you will get below figure 6.4.2.6.2.

**Fig 6.4.2.6.2: Display Selection**

```
1
Display Configuration
Time/Date Display Selection
Command : Function
  1      : Enable Time Display
  2      : Enable Date Display
  3      : Enable Alternate Date/Time Display

Press H For Help Menu
Press Q To Exit
```

- If you want Enable Time Display, Press 1 in figure 6.4.2.6.2 menu, it will set Time Display.
- If you want to Enable Date Display press 2, in figure 6.4.2.6.2 menu, it will set Date Display.
- If you want both Date/Time Alternate Display Press 3.
- By Entering “3”, it will ask to enter alternate seconds, as per below image.

**Fig 6.4.2.6.3: Alternate second**

```
3
Alternate Date/Time Display Enabled
Please Enter Second For Alternating Time & Date Display [Between 3 To 300]:5

Alternate Second Set Successfully

Press H For Help Menu
Press Q To Exit
```

- By default set Display Type is Time Display.

#### 6.4.2.6.2 “D” ”2” Command:

- Press “2” followed by enter in “D” menu for **Date Format selection** you will get below figure 6.4.2.6.4 :

**Fig 6.4.2.6.4: Date Format selection**

```
2
Display Configuration
Date Format
Command : Function
  1      : DD/MM/YY
  2      : MM/DD/YY
  3      : YY/MM/DD
Press H For Help Menu
Press Q To Exit
```

- Enter “1” followed by Enter in figure 6.4.2.6.4 menu, it will set DD/MM/YY Date Format.
- Enter “2” followed by Enter in figure 6.4.2.6.4 menu, it will set MM/DD/YY Date Format.
- Enter “3” followed by Enter in figure 6.4.2.6.4 menu, it will set YY/MM/DD Date Format.
- By Default Set format is DD/MM/YY.

#### 6.4.2.6.3 “D” ”3” Command:

- Press “3” followed by enter in “D” menu for **Time Format selection** you will get below figure 6.4.2.6.5:

**Fig 6.4.2.6.5: Time Format selection**

```
3
Display Configuration
Time Format
Command : Function
  0      : 12 Hour Time Format
  1      : 24 Hour Time Format
Press H For Help Menu
Press Q To Exit
```

- Enter “0” followed by Enter in figure 6.4.2.6.5 menu, it will set 12 Hour Time Format.
- Enter “1” followed by Enter in figure 6.4.2.6.5 menu, it will set 24 Hour Time Format.
- By default Set Type is 24 Hour Time Format.

#### 6.4.2.6.4 “D” ”4” Command:

- Press “4” followed by enter in “D” menu for **Leading Zeroes selection** in Both Type of Display , you will get below figure 6.4.2.6.6:

**Fig 6.4.2.6.6: Leading Zeroes Selection**

```
4
Display Configuration
Leading Zeroes
Command : Function
  0      : Disable
  1      : Enable
Press H For Help Menu
Press Q To Exit
```



- Enter "0" followed by Enter in figure 6.4.2.6.6 menu, it will disable Leading Zeroes.
- Enter "1" followed by Enter in figure 6.4.2.6.5 menu, it will enable Leading Zeroes.
- By default Set Type is Disable Leading Zeroes.

**For Day Display:**

- Press "D" for Display Configuration:
- By entering "D" followed by Enter you will get figure 6.4.2.6.7.

**Fig 6.4.2.6.7: Display Blink in Unlock Condition Selection**

```
D
Display Configuration
Display Blink in Unlock Condition
Command : Function
  0      : Disable
  1      : Enable

Press H For Help Menu
Press Q To Exit
```

**Fig 6.4.2.6.8: Display Blink in Unlock Condition Selection**

```
1
Display Blink Enabled in Unlock Condition

Press H For Help Menu
Press Q To Exit
```

**For Time & Date Display [DDU-TD] & Calendar [DDU-CL]:**

- Press "D" for Display Configuration:
- By entering "D" followed by Enter you will get figure 6.4.2.6.8.

**Fig 6.4.2.6.8: Display Setting for Time and Date Display [DDU-TD] & Calendar [DDU-CL]**

```
D
Display Configuration
Command : Function
  1      : Date Format
  2      : Time Format
  3      : Leading Zeroes

Press H For Help Menu
Press Q To Exit
```

#### 6.4.2.6.1.1 “D” ”1” Command:

- Press “1” followed by enter in “D” menu for **Date Format selection** you will get below figure 6.4.2.6.9 :

**Fig 6.4.2.6.9: Date Format selection**

```
1
Display Configuration
Date Format
Command : Function
  1      : DD/MM/YY
  2      : MM/DD/YY
  3      : YY/MM/DD
Press H For Help Menu
Press Q To Exit
```

- Enter “1” followed by Enter in figure 6.4.2.6.9 menu, it will set DD/MM/YY Date Format.
- Enter “2” followed by Enter in figure 6.4.2.6.9 menu, it will set MM/DD/YY Date Format.
- Enter “3” followed by Enter in figure 6.4.2.6.9 menu, it will set YY/MM/DD Date Format.
- By Default Set format is DD/MM/YY.

#### 6.4.2.6.1.2 “D” ”2” Command:

- Press “2” followed by enter in “D” menu for **Time Format selection** you will get below figure 6.4.2.6.10:

**Fig 6.4.2.6.10: Time Format selection**

```
2
Display Configuration
Time Format
Command : Function
  0      : 12 Hour Time Format
  1      : 24 Hour Time Format
Press H For Help Menu
Press Q To Exit
```

- Enter “0” followed by Enter in figure 6.4.2.6.10 menu, it will set 12 Hour Time Format.
- Enter “1” followed by Enter in figure 6.4.2.6.10 menu, it will set 24 Hour Time Format.
- By default Set Type is 24 Hour Time Format.

#### 6.4.2.6.1.3 “D” ”3” Command:

- Press “3” followed by enter in “D” menu for **Leading Zeroes selection** in Both Type of Display , you will get below figure 6.4.2.6.11:
- Enter “0” followed by Enter in figure 6.4.2.6.11 menu, it will disable Leading Zeroes.
- Enter “1” followed by Enter in figure 6.4.2.6.11 menu, it will enable Leading Zeroes.
- By default Set Type is Disable Leading Zeroes.

**Fig 6.4.2.6.11: Leading Zeroes Selection**

```
3
Display Configuration
Leading Zeroes
Command : Function
  0      : Disable
  1      : Enable

Press H For Help Menu
Press Q To Exit
```

#### 6.4.2.7 "I" Command:

- Press "I" for IRIG-B Format Selection:
- By entering "I" followed by Enter you will get figure 6.4.2.7.1.

**Fig 6.4.2.7.1: IRIG-B Format Selection**

```
I
IRIG-B Frame Format Configuration
Command : Format
  1      : IRIG-B 002/122
  2      : IRIG-B 007/127

Press H For Help Menu
Press Q To Exit
```

- Enter "1" followed by Enter in figure 6.4.2.7.1 menu, it will Set IRIG-B 002/122. In IRIG-B 002/122 Format DDU-XX does not decode Year information it will use previously entered , or previous stored Year information to display Date.
- Enter "2" followed by Enter in figure 6.4.2.7.1 menu, it will Set IRIG-B 007/127.
- By default Set Type is IRIG-B 007/127.

#### 6.4.2.8 "Z" Command:

- Press "Z" for Time Zone Offset Configuration:
- By entering "Z" followed by Enter you will get figure 6.4.2.8.1.

**Fig 6.4.2.8.1: Time Zone Offset Configuration**

```
Z
Time Zone Offset Configuration
Command : Function
  1      : View Time Zone Configuration Parameters
  2      : Enter Time Zone Offset
  3      : Enable Time Zone Offset For NTP
  4      : Enable Time Zone Offset For IRIG-B
  5      : Enable Time Zone Offset For SERIAL

Press H For Help Menu
Press Q To Exit
```

#### 6.4.2.8.1 “Z” ”1” Command:

- Press “1” followed by enter in “Z” menu for View Time Zone Configuration ,you will get Details of Current Time Zone Settings as shown in below figure 6.4.2.8.2:

**Fig 6.4.2.8.2: View Time Zone Parameter**

```
Time Zone Offset:+05:30
NTP Offset      :Disable
IRIGB Offset    :Disable
SERIEL Offset   :Disable

Press H For Help Menu
Press Q To Exit
```

#### 6.4.2.8.2 “Z” ”2” Command:

- Press “2” followed by enter in “Z” menu for to Set Time Zone offset ,you will get below figure 6.4.2.8.3:

**Fig 6.4.2.8.3: Enter Time Zone Offset**

```
2

Time Zone Offset Configuration

Press H For Help Menu
Press Q To Exit

Enter Time Zone Offset[+HH:MM or -HH:MM]:
```

- Enter Standard Time Zone in +HH:MM or –HH:MM format, any else than Standard time zone will give invalid entry message.
- By Default Time Zone Offset is +05:30.

#### 6.4.2.8.3 “Z” ”3” Command:

- Press “3” followed by enter in “Z” menu for to enable Time Zone offset for NTP input, you will get below figure 6.4.2.8.4:
- Enter “0” followed by Enter in figure 6.4.2.8.4 menu, it will disable Time zone offset for NTP.
- Enter “1” followed by Enter in figure 6.4.2.8.4 menu, it will enable Time zone offset for NTP.
- By default it is disable for NTP.

**Fig 6.4.2.8.4: Enable Time Zone Offset for NTP**

```
3

Time Zone Offset Configuration

Time Zone Offset For NTP
Command  :  Function
  0      :  Time Zone Offset Disable
  1      :  Time Zone Offset Enable

Press H For Help Menu
Press Q To Exit
```

#### 6.4.2.8.4 “Z” ”4” Command:

- Press “4” followed by enter in “Z” menu for to enable Time Zone offset for IRIG-B input, you will get below figure 6.4.2.8.5:

**Fig 6.4.2.8.5: Enable Time Zone Offset for IRIG-B**

```
4
Time Zone Offset Configuration
Time Zone Offset For IRIG-B
Command : Function
  0      : Time Zone Offset Disable
  1      : Time Zone Offset Enable

Press H For Help Menu
Press Q To Exit
```

- Enter “0” followed by Enter in figure 6.4.2.8.5 menu, it will disable Time zone offset for IRIG-B.
- Enter “1” followed by Enter in figure 6.4.2.8.5 menu, it will enable Time zone offset for IRIG-B.
- By default it is disabling for IRIG-B.

#### 6.4.2.8.5 “Z” ”5” Command:

- Press “5” followed by enter in “Z” menu for to enable Time Zone offset for SERIAL input, you will get below figure 6.4.2.8.6:

**Fig 6.4.2.8.6: Enable Time Zone Offset for SERIAL**

```
5
Time Zone Offset Configuration
Time Zone Offset For SERIAL
Command : Function
  0      : Time Zone Offset Disable
  1      : Time Zone Offset Enable

Press H For Help Menu
Press Q To Exit
```

- Enter “0” followed by Enter in figure 6.4.2.8.6 menu, it will disable Time zone offset for SERIAL.
- Enter “1” followed by Enter in figure 6.4.2.8.6 menu, it will enable Time zone offset for SERIAL.
- By default it is disabling for SERIAL.

#### 6.4.2.9 “PWD” Command:

- Press “PWD” for User Password Change:
- By entering “PWD” followed by Enter you will get figure 6.4.2.9.1.

**Fig 6.4.2.9.1: Enter Password**

```
PWD

Press 'ESC' To Exit From Password Change Mode
Enter New Password(Max 10 Characters,Case Sensitive):_
```

- Enter Password of maximum 10 character, more than 10 characters will give invalid entry.
- Password is case sensitive.

- If you enter in “PWD” window and if you want exit from that password change mode press ‘ESC’.
- By Default Password is “masibus”.

#### 6.4.2.10 “SD” Command:

- Press “SD” to set Default all Parameters:
- By entering “SD” followed by Enter, it will set all Parameters.

#### 6.4.2.11 “L” Command:

- Press “L” to View Current all Parameters:
- By entering “L” followed by Enter you will get figure 6.4.2.11.1
- In Time and Date Display unit (DDU-TD) there will be no display type option.
- In Day Display unit (DDU-DY) there will be only one option of display blink status and other options Display type, date format, time format and leading zeroes are not available.

**Fig 6.4.2.11.1: View List of Current Parameter for Time Display**

```
L
*****
List Of Current Parameters
*****
Baud Rate      :9600
Stop Bit       :1
Parity Bit      :None

IP Address      :192.168.100.032
Subnetmask     :255.255.255.000
Gateway        :192.168.100.001
Primary Server IP Address :192.168.100.153
Secondary Server IP Address :192.168.100.154
Query Interval Time[When Querying NTP Server] :0016
Query Request Time out :02
Query Retry Interval :02
Number of Time outs Before switching Servers :03
Secondary Server option for NTP :Disable

Date Format     :DD/MM/YY
Time Format     :24 Hour Time Format
Leading Zeroes  :Enable

IRIG-B Type    :007/127

Time Zone Offset :+05:30
Time Zone Offset For NTP :Disable
Time Zone Offset For IRIG-B :Disable
Time Zone Offset For SERIAL :Disable

Press H For Help Menu
Press Q To Exit
```

#### 6.4.2.12 “CS” Command:

- Press “CS” to View Current all Parameters:
- By entering “CS” followed by Enter you will get figure 6.4.2.12.1

**Fig 6.4.2.12.1: View Current Sync Information**

```
CS
Current Sync Status : Not Sync
Press H For Help Menu
Press Q To Exit
```

- This Command will print Current Sync with information.

#### 6.4.3 Important Points for Serial Configuration

- Digital Display Unit's Serial Configuration has timeout period of 2 minutes. If you do not press any character till 2 minutes, the session will be automatically closed with a message of Timeout, Session Closed.
- Commands are case insensitive, only Password is Case sensitive.

## 7. OPERATION INFORMATION

---

### 7.1 Operation as Time/Date and Day Display [DDU-TD] & Calendar Display [DDU-CL]

1. Insert the power cord into an appropriate connector inside the clock. Connector can access after open a front cover of the clock in IP65 Enclosure.
2. Upon Power up of DDU-XX, starts displaying time/date from internal RTC. After synchronization with master clock, it will take & display the time/date of master device. DDU-XX clock will start from 00:00:00, during first time Power ON & run on internal RTC until synchronizes with master clock.
3. **RS232/485 Signal as Input:**

There is auto frame detection mode is given in DDU-XX, so no switch selection is required. Connect a source of Serial Communication of GPS to the input serial connector of DDU-XX. The time should appear on the display within 60 seconds of application of time code. If the time code signal is lost or disconnected, then DDU-XX will continue to display time based on its internal RTC, until the time code signal is returned.
4. **IRIG-B TTL Signal as Input:**

Connect IRIG-B TTL as Input from master clock to the DDU-XX. Time should be display within 60 seconds of application of time, and to see the date configure on serial as Date Display or Alternate Display, DDU-XX will display current date in 4U Unit. For IRIG-B TTL input there are two options available for configuration, one is IRIG-B 002/122 format and other is IRIG-B 007/127. In IRIG-B 002/122, there is no year information will be taken from IRIG-B, TTL Input, it takes year information from RTC or entered year information by manual Time/Date Settings. In IRIG-B 007/127, DDU Will Decode Year information from Input Source.
5. **IRIG-B Amplitude Modulated Signal as Input:**

Connect IRIG-B AM as Input from master clock to the DDU-XX. Time should be display within 60 seconds of application of time, and to see the date configure on serial as Date Display or Alternate Display, DDU-XX will display current date in 4U Unit. As Described in IRIG-B TTL Input Signal, same thing will be applicable for IRIG-B Modulated signal. In IRIG-B 002/122 Format, there is no year information will be taken from IRIG-B, TTL Input, it takes year information from RTC or entered year information by manual Time/Date Settings. In IRIG-B 007/127, DDU Will Decode Year information from Input Source.
6. **ETHERNET as Input:**

Connect the RJ-45 cross cable between Ethernet port of DDU-XX & NTP Server. Ethernet Client settings for DDU-XX will be done by two way, one is use Telnet and second way is by using serial configuration, check section 6.3 and 6.4.2.5 for configuration.

  - Open the Telnet configuration window as explained in Section 6.3 of Configuration. Now Enter the I.P. address of NTP time source Server[Primary and secondary server], MASK, Gateway, and **Query interval time, Query request time out, Query Retry time, Number of time out counts** before switching servers from which you want to take reference time. After configuration close the Telnet window.
  - DDU-XX will first send query to the primary NTP server (@ every **Query interval time**) for Time code if it get response it will Lock on primary NTP server, but till the set time of Request time out it does not get response, it again send query to the primary NTP server after Retry Interval time, DDU continues try to send query after every Request time out + retry time, up to set number of counts before switching servers, after it DDU shows Unlock indication on the display for set Query interval time & after that time it will send Query to secondary NTP server when Secondary Server Option For NTP is Enabled for Time frame, if it gets Query reply from Secondary NTP server than it will get lock,
  - While synced with secondary NTP server DDU will send Query primary NTP server 6 seconds before set query interval time & wait 1 second for NTP query reply
  - If there is no reply from Primary than after 2 seconds It will send query to secondary NTP server.
  - Above Primary NTP server availability check will happen before every scheduled query interval time



- If it get NTP query reply from primary NTP server than it will shift on Primary Server with Lock condition & start working continuously on primary NTP server
  - On availability of both NTP Servers , DDU gives priority to Primary and make the query after ever set Query Interval time , on not availability of Primary NTP Server , it shift on Secondary Server and continuously check for primary NTP server.
  -
7. Connect master clock Ethernet output to RJ-45 Ethernet connector of DDU-XX. The time should appear on the display within 60 seconds of application of time code as DDU-XX synchronizes at every Query Interval time seconds with time source. If the time code signal is lost or disconnected, then DDU-XX will continue to display time based on its internal RTC, until the time code signal is returned.
8. If the clock is unable to achieve a time code lock see the section entitled **Troubleshooting Tips**.
9. For Serial/Ethernet Communication time codes date must be encoded to the standard specification. These specifications are also supported by *Masibus* Master Clock systems [see **Communication Guidelines Section**].

#### 7.1.1 Lock/Unlock Indication for Time/Date Display

- The colons of the clock display will flash if the time displayed is not locked to time code of GPS.
- When time code is present and decoded properly the colons will remain steady-on.
- DDU take decision of Lock /Unlock at every minute at 00 sec, but in NTP input it take decision on every set Query interval.
  - In case of Date in place of colons “dp” after 2<sup>nd</sup> and 4<sup>th</sup> digit will provide lock/unlock information

#### 7.1.2 AM/PM Indication for Time Display

- If the DDU-XX is configured for a 12-hour time display mode an AM/PM indicator will appear in the bottom right corner of the display during the PM hours. You will find decimal point **ON** when clock will be in PM hours in 12 hr mode.

#### 7.1.3 Lock/Unlock Indication for Day Display

- All LEDs of the Day display will flash if the day displayed is not locked to time code of GPS.
- When time code is present and decoded properly the LEDs will remain steady-on.

#### 7.1.4 Lock/Unlock Indication for Calendar Display

- The colons and dp of the clock display will flash if the time and date displayed is not locked to time code and date code of GPS respectively.
- When time and code is present and decoded properly the colons will remain steady-on.
- DDU take decision of Lock /Unlock at every minute at 00 sec, but in NTP input it takes decision on every set Query interval.

#### 7.1.4 Display Format

- In DDU-XX , have 3 option configurable
  1. Time Display
  2. Date Display
  3. Alternate Date & Time Display, which Display Both Time and Display at set alternate seconds, one by one. These Display settings can be done by Serial Configuration between 3 to 300 seconds.
- There are two Time Format selectable
  1. 12 hour format
  2. 24 hour format
- There are 3 Date format given for Display
  1. DD/MM/YY
  2. MM/DD/YY

### 3. YY/MM/DD

- There is a provision for Leading Zero Enable / Disable option for Display
- As Described above are all options for Time/Date Display and for Day Display it will show option to enable or disable the blinking of day display in unlocking condition.

#### 7.1.5 Serial Port Settings

- In DDU-XX, for serial port, there are 6 Baud rate given configurable.
  1. 4800
  2. 9600
  3. 19200
  4. 38400
  5. 57600
  6. 115200
- Parity Bit can be configurable as Even ,Odd or None
- Stop Bit can be configurable as 1 Stop bit or 2 Stop bit
- All settings can be set by Serial Configuration as shown in section 6.4

#### 7.1.6 Time Zone Offset Settings

- In DDU-XX, Configurable Time Zone option is given.
- User Can Set Standard Time zone offset between +12:00 to -12:00.
- User can also enable Time Zone for any specified input ,e.g. , if user want to add Time Zone in only NMEA serial input ,then user have to enable Time zone for Serial as shown in section 6.4.2.8 and disable other two option of IRIG-B and NTP Input
- All settings can be set by Serial Configuration as shown in section 6.4.2.8

#### 7.1.7 Manual Time Settings

- In DDU-XX, if there is no Time frame input available, at that time user can enter Manually Time and Date, Manual Time set can be done by using Serial configuration as shown in section 6.4.2.5.

#### 7.1.8 Time Frame Input Priority

- In DDU-XX, Time Frame Input Priority is given for redundancy,
- Higher to lower priority areas per below list.
  1. Serial(NMEA,NGTS,T-FORMAT)
  2. IRIG-B TTL
  3. IRIG-B MODULATED
  4. NTP (Primary Server)
  5. NTP (Secondary Server)
- First priority is given to Serial , so if user had connected more than 2 or all Time Frame Inputs , DDU-XX will take Time from First Serial and in case of non availability of Serial, it will shifts on second highest priority , and follows above sequence.
- If DDU-XX is Sync with High Priority input, in case the High Priority input will be removed or not available at that time it Blinks Colon for 1 minute [Other than NTP, For NTP it will not wait for 00 but will stay Unlock for Query Interval Time], and shift on lower priority inputs, this sequence of colon blink is followed by every time when DDU-XX shift from Higher to Lower Priority Input.
- In case of if device Shifts from lower to higher priority input that time colon stays steady on does not blinks.
- Every time DDU tries for Higher priority inputs, if it is working on other than serial input

## 7.2 Operation as Frequency Display.

1. Insert the power cord into an appropriate connector of the clock. Connector can access after open a front cover of the clock in IP-65 Enclosure where as in IP-20 enclosure it will be on the back/bottom side of the Enclosure.

2. **AC Voltage Raw Data as Input:**

- 2.1 Upon Powering up DDU-Hz, displays frequency 00.000 Hz. After receiving detectable AC signal as input at appropriate connector unit will measure & then display Input Frequency with resolution of three decimal points.
- 2.2 Display of inserted signal frequency will be stabilized after 2 to 3 second of power ON.
- 2.3 When no input signal is given to the unit it will display 00.000 Hz frequency & the frame output of the unit is also transmits according to displayed data.
- 2.4 Do proper switch selection of Baud Rate for frame output; the frame format in which frequency data is transmitted is described in 8.4 sections.

3. **RS232/485 Signal as Input:**

- 3.1 Upon Powering up unit will display frequency based on received frame. After receiving detectable frame from SCADA it sends <ACK> byte otherwise responds as <NACK>. DDU-HZ will start from 00.000, during first time Power ON.
- 3.2 Does proper switch selection for Unit ID to communicate. Connect a source of Serial Communication to the input serial connector of DDU-HZ module. The transmitted data should appear on the display immediately. If the simple protocol frame signal is lost or disconnected, then DDU-HZ module will continue to display data based on stored in its database, until new frame is received.
- 3.3 After receiving correct frame unit will acknowledge master by transmitting <ACK> byte & display received data and unit is not going to change data until it receives next correct frame.
- 3.4 DDU-HZ module transmits <ACK> byte every time it receives correct frame.
- 3.5 DDU-HZ module transmits <NACK> byte every time it receives wrong frame.

4. **Ethernet Port based signal as Input:**

Refer Appendix-A\_301\_00

5. If the unit is unable to display frequency data then see the section chapter: 9 **Troubleshooting Tips**.

## 8. COMMUNICATION GUIDELINES

### 8.1 Serial Time Frame Input

#### 8.1.1 NMEA-0183[RMC] Format

The \$GPRMC sentence contains time and date of position fix, speed and course information. The following examples show the contents of a typical RMC sentence:

The settings for this serial format is 9600, 8, N, 1.

The full data message of this format shall consist of data fields as follows:

**Table 9: NMEA-0183[RMC] Format**

Field	Example	Comments
Sentence ID	\$GPRMC,	
UTC Time	130525.00,	hhmmss.ss,
Status	A,	A = Valid/V = Invalid,
Latitude	4250.5589,	ddmm.mmmm,
N/S Indicator	S,	N = North/S = South,
Longitude	14518.5084,	dddmm.mmmm,
E/W Indicator	E,	E = East/W = West,
Speed over ground	000.1,	Knots,
Course over ground	245.0,	Degrees,
UTC Date	291206,	DDMMYY,
Magnetic variation	,	Degrees,
Magnetic variation	,	E = East/W = West,
Checksum	*25	*CC
Terminator	<CR><LF>	Non-printing characters

#### 8.1.2 NGTS Format

The settings for this format are programmable. The full data message of NGTS format shall consist of 14 printable characters and a concluding CRLF as follows:

**Table 10: NGTS Format**

Description	Number of Characters	Character Position	Range of Value/Information
Code Identification	1	1	Capital T
Year in Century	2	2,3	0 to 99
Month	2	4,5	1 to 12
Day of Month	2	6,7	1 to 31
Day of Week	1	8	1 to 7
Hours	2	9,10	0 to 23
Minutes	2	11,12	0 to 59
GMT Marker	1	13	0 or 1
Validity Marker	1	14	0 or 1
CRLF	2	15,16	Non-printing character

The transmission sequence shall be from the Code Identification character through to the CRLF with the most significant digits being transmitted first.

The message shall become automatically available at one second prior to the clock minute epoch.

### 8.1.2 T-Format

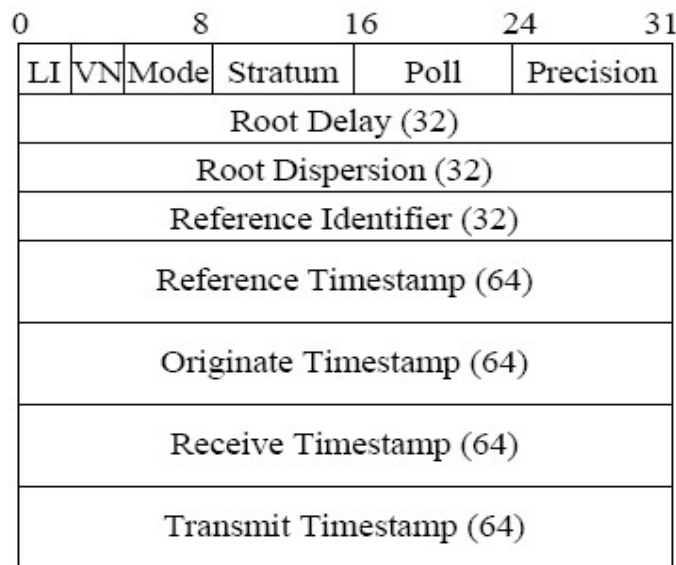
The settings for this format are programmable. The full data message of T-format shall consist of 21 printable characters with a concluding CRLF as follows:

**Table 11: T-Format**

Description	Number of Characters	Character Position	Range of Value/Information
Code Identification	1	1	Capital T
Divider	1	2	:
Year in Century	2	3,4	0 to 99
Divider	1	5	:
Month	2	6,7	1 to 12
Divider	1	8	:
Day of Month	2	9,10	1 to 31
Divider	1	11	:
Day of Week	1	12	1 to 7
Divider	1	13	:
Hours	2	14,15	0 to 23
Divider	1	16	:
Minutes	2	17,18	0 to 59
Divider	1	19	:
Seconds	2	20,21	0 to 59
Divider	1	22	:
GMT Marker	1	23	0 or 1
Validity Marker	1	24	0 or 1
CRLF	2	25,26	Non printing character

### 8.2 NTP Packet format:

**Fig 8.1: NTP packet header format**



NTP Message Header

Following is the description of each parameter in NTP Packet:

**Leap** 2-bit integer warning of an impending leap second to be inserted or Deleted in the last minute of the current month, coded as follows:  
0 no warning  
1 last minute of the day has 61 seconds  
2 last minute of the day has 59 seconds  
3 alarm condition (the clock has never been synchronized)

**Version.** 3-bit integer representing the NTP version number.

**Mode** 3-bit integer representing the mode, with values defined as follows:  
4 server

**Peer clock stratum** 8-bit integer representing the stratum, with values defined as follows:  
0 unspecified or invalid  
1 primary server (e.g., equipped with a GPS receiver)  
2-255 secondary server (via NTP)

**Polling interval** can be set between 16 to 1024; it is representing the maximum interval between successive Queries.

**Clock precision** 8-bit signed integer representing the precision of the system clock. GPS is having clock precision of 1 us (1 microseconds = 0.000001s)

**Root Delay** Total roundtrip delay to the reference clock, in NTP short format.

**Root Dispersion** Total dispersion to the reference clock, in NTP short format.

**Reference clock id.** 32-bit code identifying the particular server or reference clock.  
GPS Global Positioning System

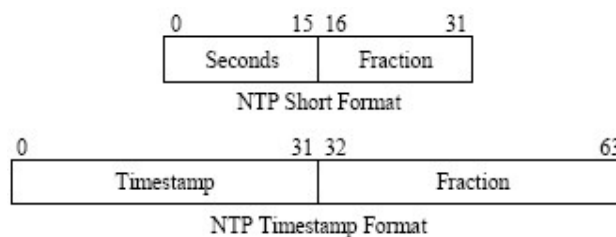
**Reference clock update time** Time when the system clock was last set or corrected, in NTP timestamp format.

**Originate timestamp** Time at the client when the request departed for the server, in NTP timestamp format.

**Receive timestamp** Time at the server when the request arrived from the client, in NTP timestamp format.

**Transmit timestamp** Time at the server when the response left for the client, in NTP timestamp format.

**Fig 8.2: NTP Timestamp Format**



Follow [www.ntp.org](http://www.ntp.org) for more details for NTP Time Format and Client Settings..

### 8.3 The IRIG-B Signal

The IRIG-B format is a serial format based on a message frame per second which is Co-ordinated with the synchronized 1pps time output pulse. There are two alternative forms of output, a dc level shift output, and a modulated output. The modulation frequency is 1 KHz.

For each form of output there are three output codes:-

- a. A Reference Mark
- b. A logical 1
- c. A logical 0

For IRIG-B, each one of these codes is 10 ms long, which is 10 cycles for the modulated format. There are 100 possible codes per time frame, although not all of them are used. The code sequence is shown in Table 1, and the waveforms shown in Figure 2. The day number starts at 1 on the first of January.

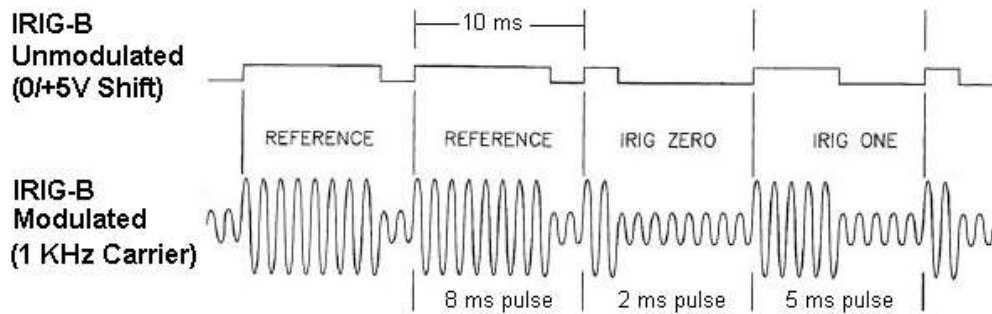
The output voltage of the modulated waveform is 3 V peak to peak into a 50 ohms load. The dc level output is TTL standard and the rising edge of the pulse is "On Time". 1 kHz modulated IRIG-B signal is connected to BNC on the rear panel of the device. IRIG-B TTL level signal is connected to a BNC connector on the rear panel of the device.

**Table 12: IRIG B Code Sequence**

Bit	Weight	Meaning	Bit	Weight	Meaning	Bit	Weight	Meaning	Bit	Weight	Meaning	Bit	Weight	Meaning
00	P <sub>r</sub>	Frame marker	20	1	Hours (0–23)	40	100	Day of year (1–366)	60	0	Unused, available for Control Functions	80	1	Straight Binary Seconds (0–86399)
01	1	Seconds (00–59)	21	2		41	200		61	0		81	2	
02	2		22	4		42	0	62	0	82		4		
03	4		23	8		43	0	63	0	83		8		
04	8		24	0		44	0	64	0	84		16		
05	0		25	10		45	0.1	65	0	85		32		
06	10		26	20		46	0.2	66	0	86		64		
07	20		27	0		47	0.4	67	0	87		128		
08	40		28	0	48	0.8	68	0	88	256				
09	P <sub>1</sub>	Position identifier	29	P <sub>3</sub>	Position identifier	49	P <sub>5</sub>	Position identifier	69	P <sub>7</sub>	Position identifier	89	P <sub>9</sub>	
10	1	Minutes (00–59)	30	1	Day of year (1–366)	50	1	Year (00–99)	70	0	Unused, available for Control Functions	90	512	
11	2		31	2		51	2		71	0		91	1024	
12	4		32	4		52	4		72	0		92	2048	
13	8		33	8		53	8		73	0		93	4096	
14	0		34	0		54	0		74	0		94	8192	
15	10		35	10		55	10		75	0		95	16384	
16	20		36	20		56	20		76	0		96	32768	
17	40		37	40		57	40		77	0		97	65536	
18	0	Unused	38	80	58	80	78	0	98	0	Unused			
19	P <sub>2</sub>	Position identifier	39	P <sub>4</sub>	Position identifier	59	P <sub>6</sub>	Position identifier	79	P <sub>8</sub>	Position identifier	99	P <sub>0</sub>	Position identifier

Note\*\*Bit not 45 -48 and 80 to 97 we are supporting, Tenths of seconds and Straight Binary Seconds.

**Fig 8.3: IRIG-B Code Structure**



## 8.3 Serial Frame Format for Frequency Data INPUT

### 8.3.1 Simple Packet Communication Format

The format of **Simple Packet** communication is:

“<SOH> Type Address: Command Data Terminator”

#### <SOH>:→

The symbol **<SOH>** represents the ASCII "Start Of Header" character (01 hex/1 decimal), and must be the first character of every transmission. Since the purpose of the **<SOH>** character is to mark the beginning of a new packet, it cannot appear anywhere else within the transmission.

#### Type:→

Type can be one of two ASCII characters (**S** or **s**), and must be the second character of every transmission. This character lets the display know if the serial data is meant for an individual address or a group address. **S** Serial data for an individual address. **s** Serial data for a group address. If your application does not require addressing individual displays or groups of displays, you should use the type **s**. This will allow data that you send to be acted upon by every display that receives it.

#### Address:→

Address can range from **1** to **16**, and is an optional part of the packet that specifies an actual unit or group address. If no address is included in the packet, the default address of **1** will be used. All the addresses are selectable using the internal DIP switch. When no addressing is required, you can skip the **Address** part of the packet, and rely on the fact that a default address of 0 will automatically be substituted. In this case, the complete header before the data would be **<SOH>s:** and the data will be acted on by all displays that receive it. The ASCII "Colon" character (3A hex/58 decimal) must be included in every transmission, and is used to separate the header part of the packet from the data.

#### Command:→

Command can contain one command string for the display. Command strings can be used to display data.

#### Data:→

Data means any ASCII characters you wish to display. The control characters **<SOH>**, **<CR>** and **<LF>** cannot be used in the **Data** part of the packet, as they are reserved for marking the beginning and end of packets.

#### Terminator:→

A special ASCII character which marks the end of the data. The Terminator character is a DIP switch selection. Note that the symbol **<CR>** represents the ASCII "Carriage Return" character (0D hex/13 decimal), and the symbol **<LF>** represents the ASCII "Line Feed" character (0A hex/10 decimal). In cases where the host device transmits a **<CR><LF>** combination as the terminator, select **<CR>** as terminator.



### 8.3.2 Simple Packet Command

The command portion of the packet can contain one (and only one) command string for the display. Command strings can be used to display data. This command is fully described below. Remember that the control characters **<SOH>**, **<CR>** and **<LF>** cannot be used anywhere in the data portion of the packet, as they are reserved for marking the beginning and end of packets.

#### Frequency Display Data (F)

Data to be displayed is preceded by the ASCII character **F** (46 hex/70 decimal). Note that the **F** must be upper case. The data will be displayed in a fixed manner. The following examples assume that addressing is not being used, and that Terminator has been selected as **<CR>**. Also note that the header of the packet **<SOH>s:** has the effect of broadcasting to all displays, overriding any group or individual address a display might be set to.

To Show on the Display	Transmit
49.950	<SOH>s:F 49.950<CR>
51.101	<SOH>s:F 51.101<CR>

### 8.3.3 Addressing Multiple Displays

Using an RS-485 network together with addressing allows a host computer or PLC to communicate with specific individual displays or groups of displays in a network. Each display in the network may be assigned a unit address. If you do not need to address individual displays simply leave the display set to the default setting of Terminator only (DIP switches SW1, 2, 3, 4 OFF), and skip this section.

#### Unit Address

Unit Address is a DIP switch selection that allows you to select an individual unit address. Individual unit addresses can range from **1** to **16**, allowing up to 16 displays to be individually addressed in a network, using the DIP switch. If a packet is directed to a specific unit address, only units set to that address will respond to the data. Remember, if the data in the packet is meant for a specific unit address, the serial data type **S** must follow the **<SOH>** character in the transmission packet (as shown in the examples below).

The following examples assume that Unit Address is set to **10** and that Terminator has been selected as **<CR>**. Also note that an upper case **S** follows the **<SOH>** indicating that the serial data is intended for an individual display address, and the **F** command character is being used to display Frequency data.

To Show on the Display where Unit address is 10	Transmit
49.950	<SOH>S10:F 49.950<CR>
51.101	<SOH>S10:F 51.101<CR>

### 8.3.4 Using Command Acknowledgment

Use of command acknowledgment can improve the reliability of data transfer between the host device and the display.

Command acknowledgment is used to let the host device know if data received by the display can be acted upon (i.e. the data is valid for the command transmitted, and the command and data are appropriate for the particular display). Command acknowledgment provides a means of letting the host device know that the data was received proper.

The DDU-HZ Display responds to serial requests for information using **<ACK>/<NACK>** bytes. DDU-HZ unit will return a status string for each serial command received. In response to a valid

command the DDU-HZ unit will respond with the ASCII character **<ACK>** (06 hex/6 decimal). If the received frame is incorrect then DDU-HZ Unit will produce a response of **<NAK>** (15 hex/21 decimal).

### 8.4 Serial Frame Format for Frequency Data OUTPUT

In case of AC Voltage raw data based frequency display serial frame format will be given as output from DDU-Hz unit.

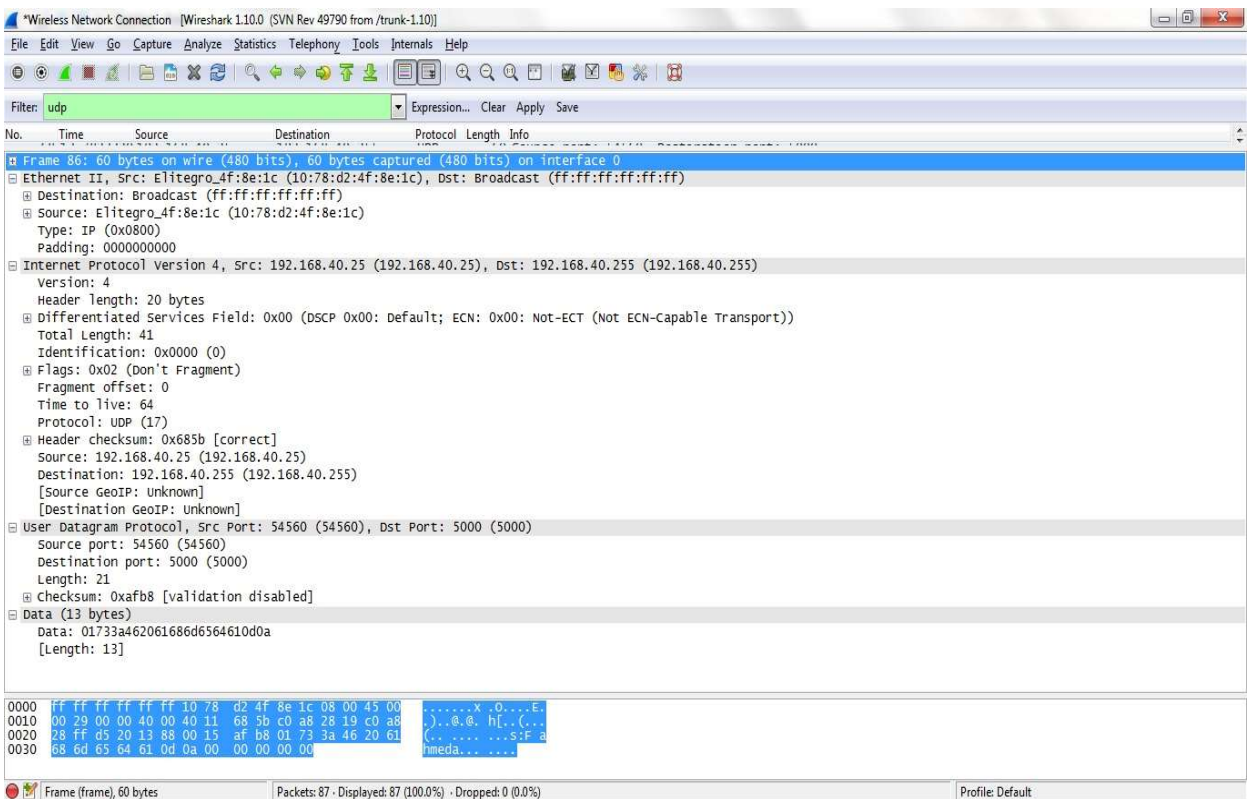
For Frequency Data OUTPUT, Frame format will be same as Frequency Data INPUT as mentioned in Section 8.3 with below exception.

Available only in Group addressing mode's', so there is no Address field available.

Command Acknowledgment is not available.

### 8.5 UDP Packet Format for Frequency Display Unit

For Frequency Display unit DDU-HZ data comes from UDP Packet on the Port Number-**09** the Packet information is given below figure.



## 9. TROUBLESHOOTING TIPS

---

If the operating display does not appear after turning on the controller's power, follow the measures in the procedure below.

If a problem appears complicated, contact our sales representative.

### **IMPORTANT**

Take note of the parameter settings when asking the vendor for repair.

Time Code decoding problems can include any of the following:

- No Time Code present
- Ground loops or other interference such as coupling from nearby AC power lines, bad/intermittent cables, wiring or connectors incorrect wiring connection for unbalanced or balanced input signals
- Out of range signal level that is too high or too low
- Fluctuating signal level
- A signal that is distorted
- Excessive loading on the Time Code line
- A Time Code that your clock does not support

**Problem:** Clock is unable to "Lock" to time code after 2 minutes.

#### **Possible reasons/solutions:**

1. Close the TELNET configuration window, if DDU-XX is under configuration over TELNET Protocol.
2. Use **Cross** CAT5 or equivalent cable for synchronization of DDU-XX with Master Clock / Desktop Computer.
3. Use **Straight** communication cable for RS-232 / 485 for DDU-XX synchronization with Master clock.
4. Check the connectivity of DDU-XX in LAN using ping command. (if Ethernet as input)
5. Verify that switches are selected as per input time code and proper baud rate is selected.
6. Check all the input signals voltage level for DDU-XX synchronization. E.g. IRIG-B TTL/PWM – Varies between 1.4 – 2.4V DC, IRIG-B AM/Modulated – Varies between 0.5 – 0.6V AC, RS232 – approx. 10.4 V DC, RS-485 – Varies between 0-5 V DC. Here these voltages are measured with multi meter. This is not the exact voltage level of any signal but this gives ruff idea about signal presence on port.
7. The time code being fed to the DDU-XX must be recognized format. Verify that your time code source is providing one of the time code formats that the DDU-XX can decode & match its frame length as per standard.

**Problem:** Not displaying the correct local time and/or date.

#### **Possible reasons/solutions:**

1. For Ethernet: Required time zone offset needs to be configuring using TELNET Protocol. For Detail description refer section 6.3.2.  
For Serial communication: NGTS & T format supports IST only.  
In case of NMEA (\$GPRMC) frame format selection, Switch setting needs to be done for IST display. (Refer Table 4)
2. If LED in DDU-XX blinks after the time zone configuration done in DDU-XX, reset the power of the DDU-XX is must for effective synchronization.
3. Your Time Code source is not providing the time and/or date that you expect. Contact the individual responsible for the Time Code source for more information

**PROBLEM:** UTC time and/or date is incorrect.  
**There are several potential failure points:**

- Invalid, intermittent or missing Time Code source
  - Date/year overwrite function for non-date encoded Time Code may be configured improperly
  - Battery may need to be replaced
  - A local Time Zone configuration not set correctly
1. Verify that your Time Code source is generating the UTC referenced time and date that you expect and that this Time Code format is at an acceptable signal level and quality that can be detected at the client side (i.e. DDU-XX input).
  2. If you are using in-house Time Code, verify that the Time Code source is locked to the GPS satellite system for UTC Time Code. Time Code sources such as SMPTE Time Code that is fed via a broadcast satellite will have a delay due to the satellite transmission. Your clock cannot compensate for satellite transmission delays.
  3. If you are using a Time Code source from another vendor, be certain your Time Code contains encoded year/date information to the IEEE 1344 (IRIG-B).
  4. If your Time Code source is providing DST adjustments, these functions must be checked if it is applicable or not at that time & place.
  5. If your Time Code source is providing Time Zone offsets these functions must be disabled in your DDU-XX in order to eliminate double offsets.
  6. Check Configured IRIG-B 002/122 or IRIG-B 007/127 Format, If you have configured IRIG-B 002/122 Format , then it will not decode Year in case of IRIG-B Frame input both TTL and Modulated input it shows previously stored Year information, so for IRIG-B 002/122 , manually Set time/Date.

**PROBLEM:** Clock is unable to find NTP reference.  
**Possible reasons/solutions:**

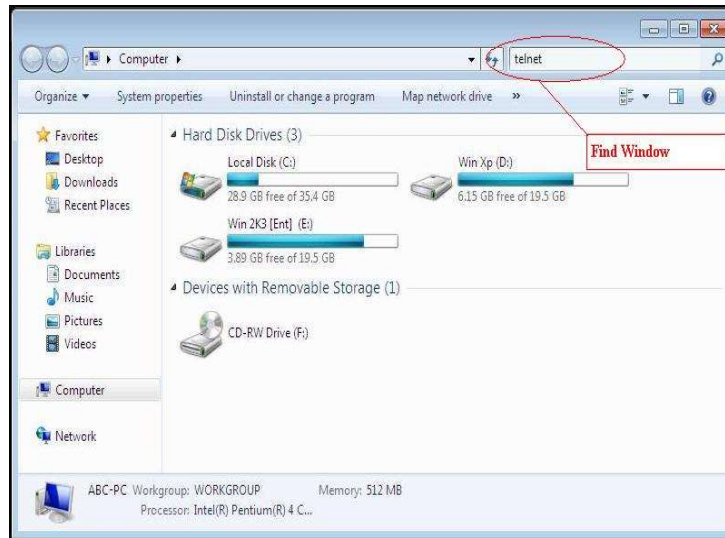
1. Verify that the NTP server(s) specified are reachable, communicating, and are not flagging their reported time as invalid.
2. Verify that a gateway/router/firewall has been configured that allows the clock to communicate outside of its local network.
3. Verify that the IP address configured for the clock is correct. If you manually enter an IP address that already exists on the network, this will create an IP address conflict.  
 , obtain a new IP address for the clock or resolve the duplication. Consult your IT/Network Administrator for a list/range of available IP addresses to avoid IP address conflicts.
5. Verify that the clock is connected to the Ethernet LAN.
6. Verify that all network cables, hubs, etc. are in proper working order. Be sure that Ethernet crossover "patch cables" are not being used where inappropriate.

**PROBLEM:** Unit is unable to display correct data.  
**Possible reasons/solutions:**

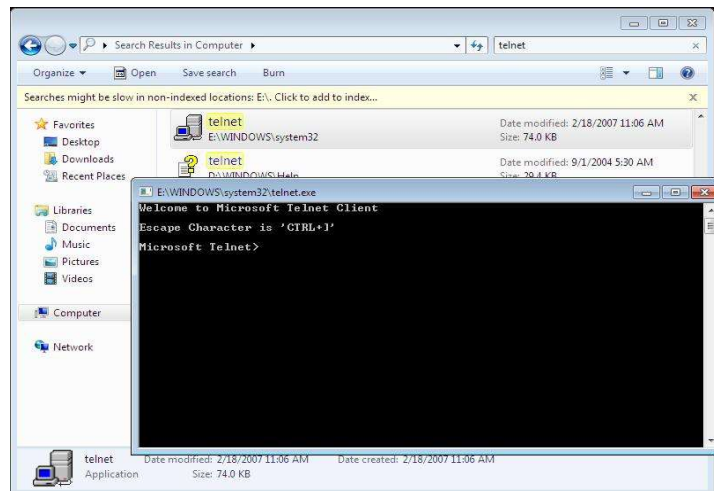
1. Verify that switches are selected as per Slave Device ID and proper baud rate is selected.
2. Verify that a transmitted frame format for DDU-HZ unit is in recognizable format.
3. Verify that communication cable is straight having no connectivity issues.

### TELNET Configuration for WINDOWS 7:

If TELNET window is not opening in windows-7 Operating System, then go to My Computer → Find window → write TELNET as shown in below Picture.



By Pressing enter you can see the TELNET file. By double clicking on that TELNET file it will open new window as shown in below figure.



***If these troubleshooting tips do not solve your problem then, please contact technical support at either nearest area office or Main Head Office as given on the first page.***

## 10. REVISION HISTORY

---

Following Changes added in m06bom301-06 compared to m06bom301-05.

1. Terminal connection of IP20 wall mount image Update.

Following Changes added in m06bom301-07 compared to m06bom301-06.

1. Masibus old logo replaced with a new one.

Following Changes added in m06bom301-08 compared to m06bom301-07.

1. Terminal connection of IP20 wall mount image Update.
2. List of Accessories are updated.

**Masibus Automation & Instrumentation Pvt. Ltd.**  
**Customer Support Division**

B/30, GIDC Electronics Estate,  
Sector-25, Gandhinagar-382024, Gujarat, India

Ph: 91-079-23287275-77

Fax: 91-079-23287281

Email: support@masibus.com

Web: www.masibus.com