

## User's Manual

# DDU-44/46 DDU-TM-44/46



### Masibus Automation And Instrumentation Pvt. Ltd.

B/30, GIDC Electronics Estate,  
Sector-25, Gandhinagar-382024, Gujarat, India

☎ +91 79 23287275-77    📠 +91 79 23287281

Email: [support@masibus.com](mailto:support@masibus.com)

Web: [www.masibus.com](http://www.masibus.com)

# CONTENTS

<b>LIST OF TABLES .....</b>	<b>4</b>
<b>LIST OF FIGURES.....</b>	<b>4</b>
<b>1. INTRODUCTION .....</b>	<b>5</b>
Foreword.....	5
Notice .....	5
Trademarks .....	5
Checking the Contents of the Package.....	5
List of Accessories .....	5
Product Ordering Code .....	6
Safety Precautions.....	6
<b>2. SPECIFICATIONS.....</b>	<b>7</b>
2.1 Technical Specification Sheet.....	7
2.2 Time Signal Input .....	8
2.3 Time Signal Output .....	8
<b>3. FRONT PICTURE .....</b>	<b>9</b>
3.1 DDU-44/DDU-TM-44 IP20 Front views: .....	9
3.2 DDU-44/DDU-TM-44 IP20 (SS Front Plate) Front views: .....	10
3.3 DDU-46/DDU-TM-46 IP20 Front views: .....	11
3.4 DDU-46/DDU-TM-46 IP20 (SS Front Plate) Front views: .....	12
3.5 DDU-44/DDU-TM-44 XP Front views:.....	13
<b>4. INSTALLATION &amp; MOUNTING DETAIL .....</b>	<b>14</b>
4.1 Safety Precautions in Installation .....	14
4.2 Wall Mount.....	14
4.3 Panel Mount .....	17
4.4 Flush Mount .....	18
<b>5. TERMINAL CONNECTIONS.....</b>	<b>20</b>
5.1 Terminal connections on DDU-TM-44/46 or DDU-44/46 Enclosures .....	20
5.2 How to connect wires .....	21
<b>6. CONFIGURATION GUIDELINES.....</b>	<b>24</b>
6.1 Default Configuration.....	24
6.2 Key Configuration: .....	25
<b>7. OPERATION INFORMATION .....</b>	<b>63</b>

7.1 Operation as Time/Date Display [DDU-TM-44/46 or DDU-44/46] ..... 63

**8. COMMUNICATION GUIDELINES ..... 66**

8.1 Serial Time Frame Input ..... 66

8.2 Wireless Time Frame Input..... 67

8.3 Wireless Configuration Frame Input..... 68

8.4 NTP Packet format: ..... 68

8.5 SNMP Protocol ..... 69

8.6 Serial Time Frame Output ..... 73

**9. TROUBLESHOOTING TIPS ..... 74**

**REVISION HISTORY ..... 77**

## LIST OF TABLES

Table 1 List of Accessories .....	5
Table 2 Product Ordering Code for DDU-TM-44/46 or DDU-44/46 .....	6
Table 3 Terminal Connection Detail of Enclosures (Wall Mount) .....	20
Table 4 Terminal Connection Detail of Enclosures (Panel Mount) .....	21
Table 5 Error Message Display Code .....	62
Table 6 NMEA-0183[RMC] Format .....	66
Table 7 NGTS Format .....	66
Table 8 T-Format .....	67

## LIST OF FIGURES

Figure 1 Front View of DDU-44 IP20 .....	9
Figure 2 Front View of DDU-TM-44 IP20 .....	9
Figure 3 Front View of DDU-44 IP20 (SS Front Plate) .....	10
Figure 4 Front View of DDU-TM-44 IP20 (SS Front Plate) .....	10
Figure 5 Front View of DDU-46 IP20 .....	11
Figure 6 Front View of DDU-TM-46 IP20 .....	11
Figure 7 Front View of DDU-46 IP20 (SS Front Plate) .....	12
Figure 8 Front View of DDU-TM-46 IP20 (SS Front Plate) .....	12
Figure 9 Front View of DDU-44-XP .....	13
Figure 10 Mounting detail for 4" 4 Digits [460mm x 175mm x 70mm] Enclosure (Wall Mount) .....	14
Figure 11 Mounting detail for 4" 4 Digits [500mm x 215mm x 79mm] Enclosure (Wall Mount, SS Front) .....	15
Figure 12 Mounting detail for 4" 6 Digits [665mm x 175mm x 70mm] Enclosure (Wall Mount) .....	15
Figure 13 Mounting detail for 4" 4 Digits [570mm x 260mm x 85mm] XP Enclosure .....	16
Figure 14 Mounting detail for 4" 6 Digits [705mm x 215mm x 79mm] Enclosure (Wall Mount, SS Front) .....	16
Figure 15 Mounting detail for 4" 4 Digits [460mm x 175mm x 70mm] Enclosure (Panel Mount) .....	17
Figure 16 Mounting detail for 4" 6 Digits [665mm x 175mm x 70mm] Enclosure (Panel Mount) .....	17
Figure 17 Mounting detail for 4" 4 Digits [500mm x 215mm x 79mm] Enclosure (Flush Mount) .....	18
Figure 18 Mounting detail for 4" 6 Digits [705mm x 215mm x 79mm] Enclosure (Flush Mount) .....	19
Figure 19 Connection on Terminal plate of DDU-TM-44/46 or DDU-44/46 Wall Mount .....	20
Figure 20 Connections on Base Plate of DDU-44-XP (Wireless Model) .....	20
Figure 21 Connection on Terminal plate of DDU-TM-44/46 or DDU-44/46 [NTP Model] .....	20
Figure 22 Connection on Terminal plate of DDU-TM-44/46 or DDU-44/46 Panel Mount .....	21
Figure 23 RS232 Connection Details .....	22
Figure 24 RS485 Connection Details .....	22
Figure 25 NTP + PoE connection Detail .....	22
Figure 26 Display and Key Configuration Detail .....	26
Figure 27 Wireless Network of DDU-TM-44 .....	68
Figure 28 NTP packet header format .....	68
Figure 29 NTP Timestamp Format .....	69
Figure 30 MIB Browser .....	71
Figure 31 GET Command of MIB Browser .....	73

## 1. INTRODUCTION

### Foreword

Thank you for purchasing Display Unit

**DDU-TM-44/DDU-44** (Time Display Unit, 4" [100 mm], 4 Digit LED Display)

**DDU-TM-46/DDU-46** (Time Display Unit, 4" [100 mm], 6 Digit LED Display)

This manual describes the basic functions and operation methods. Please read through this user's manual carefully before using the product.

### Notice

The contents of this manual are subject to change without notice as a result of continuous improvements to the instrument's performance and functions.

Every effort has been made to ensure accuracy in the preparation of this manual. Should any errors or omissions come to your attention, however, please inform MASIBUS Sales office or sales representative. Under no circumstances may the contents of this manual, in part or in whole, be transcribed or copied without our permission.

RF and Serial Communication related information will be applicable as per ordering code.

If RF based unit is selected then ignore Serial communication information and if Serial communication based unit is selected then ignore RF related information.

### Trademarks

Our product names or brand names mentioned in this manual are the trademarks or registered trademarks of Masibus Automation and Instrumentation (P) Ltd. (herein after referred to as *masibus*).

Adobe, Acrobat, and Postscript are either registered trademarks or trademarks of Adobe Systems Incorporated. All other product names mentioned in this user's manual are trademarks or registered trademarks of their respective companies.

### Checking the Contents of the Package

Unpack the box and check the contents before using the product. If the product is different from which you have ordered, if any parts or accessories are missing, or if the product appears to be damaged, contact your sales representative.

### List of Accessories

The product is provided with the following accessories according to the model and suffix codes (see the table below). Check that none of them are missing or damaged.

**Table 1 List of Accessories**

No	Item name	Part number	Qty	Remarks
1	Operational Manual	M06com101	1	
2	Mounting Clamps	-	2	For Wall Mount unit
3		-	2	For Panel Mount Clamp
4	Mounting Screw	-	4 or 6	4-DDU-44/DDU-TM-44 6-DDU-46/DDU-TM-46 For Flush Mount Enclosure

## Product Ordering Code

**Table 2 Product Ordering Code for DDU-TM-44/46 or DDU-44/46**

Ordering Code										
Model	Display Size		No Of Digits		Mounting		Input Type1		Input Type2	
DDU / DDU-TM	X		X		X		X		X	
	4	4"	4	4 Digits	W	Wall(IP20)	N	None	N	None
			6	6 Digits	R	Panel/Rack Mount (IP20)	1	Wireless(RF)	1	RS232
					F	Flush Mount(IP20)	2	NTP	2	RS485
					XP	Flame Proof(IP65)	3	NTP+PoE		

**Note:** Flush Mount Enclosure is available with SS (SS-304) Front Plate without Conceal Box with Wall Mount Key Holes.

DDU-44 Enclosure available in Flame Proof model only.

NTP + PoE option will not have 85- 265 VAC Supply

### Accessories (Optional-On request)

Mounting Clamp	
Wall Mount Clamp	Panel Mount Clamp

## Safety Precautions

The product and the instruction manual describe important information to prevent possible harm to users and damage to the property and to use the product safely.

Understand the following description (signs and symbols), read the text and observe descriptions.

### DESCRIPTION OF SIGNS

**Note:**

For Frequency display unit in case of Ethernet or Line Frequency input type, RS232 serial port will be given for firmware up gradation

	<b>WARNING</b>	<i>This indicates a danger that may result in death or serious injury if not avoided.</i>
	<b>CAUTION</b>	<i>This indicates a danger that may result in minor or moderate injury or only a physical damage if not avoided.</i>

## 2. SPECIFICATIONS

### 2.1 Technical Specification Sheet

Specifications	DDU-TM-44 / DDU-44	DDU-TM-46 / DDU-46
<b>Display</b>		
No of Digit	Four	Six
Digit Height	4"(100mm)	
Type of display	LED	
Display Color	RED	
Display Format	Time: HH:MM Date: DD:MM / MM:DD	TIME:HH:MM:SS DATE:DD:MM:YY/MM:DD:YY:YY:MM:DD
12/24 Hour Mode	✓	✓
AM/PM Indication	✓	✓
International Time Zone	✓	✓
<b>User Interface</b>		
Push Button Switch (For Configuration)	✓	✓
Password Protected	✓	✓
<b>RF Wireless Communication</b>		
Wireless frequency	866 MHz	
Antenna	Integrated antenna	
Receiver Sensitivity	-121 dBm	
Transmitter Power	+20 dBm	
Line of Site Range(Approx.)	600 meters (depends on site conditions); 100meters with obstacles; 50 meters with obstacles for slave to slave	
<b>Serial Communication (RS232 / RS485)</b>		
Protocols	NMEA-0183[RMC] / NGTS/ T – Format	
Baud Rate	9600/ 19200	
Terminal	4 pin, Plug-in type Connector, <b>Wire:</b> 2.5mm <sup>2</sup>	
<b>Power Supply</b>		
Power	AC: 85-265 V, 50-60 Hz, 1Ph & DC: 100-300 V	
Power Consumption	< 5W	
Terminal	3 pin, Plug-in type Connector; <b>Wire:</b> 2.5mm <sup>2</sup>	
<b>Environmental</b>		
Operating temperature	0 °C to +55 °C	
Storage temperature	-20 °C to +80 °C	
<b>Internal RTC Accuracy</b>		
Internal RTC Accuracy	±15PPM From 0 °C to +55 °C(Slave to Slave Delay <=1s)	
<b>Physical</b>		
Enclosure Protection	IP 20	
Size [ H x W x D] [in mm]	460mm x 175mm x 70mm(MS Enclosure) 500mm x 215mm x 79mm(SS Front)	665mm x 175mm x 70mm (MS Enclosure) 705mm x 215mm x 79mm (SS Front )
Weight(approx.)	2.78Kg(MS Enclosure) 3.0Kg(SS Front)	4.0Kg (MS Enclosure) 4.1Kg (SS Front)
Material	Mild Steel/SS(SS-304 Only Front Plate)	
Mounting	Wall Mount/ Panel Mount/Flush Mount	

**Note: DDU-44/46 is available with SS (SS-304) Front Plate without Conceal Box with Wall Mount Key Holes.**

Optional NTP [LAN Interface] for Slave Clocks		Optional PoE [Power Over Ethernet] for NTP Slave Clocks	
Time Sync Protocol	NTP V3, UDP, Telnet , SNMP V2C	Standard	IEEE 802.3af
Internet Protocol	IP V4	Input Supply Voltage	48VDC[36VDCmin - 57VDCmax]
Mode	Client	Power Consumption	< 6W
Protocol Time Format	UTC	Terminal	100BaseT, RJ45
Physical Interface	RJ45, 10/ 100 Mbps	Cable	CAT 5

DDU-44-XP			
Mechanical		Mounting	
Enclosure Protection	IP65	Mounting	Wall mounting with the help of 4 NOS bolts of size M8
Size [ H x W x D ] [in mm]	260mm X 570mm X 85mm	Cable entry size/no	3/4" ET-3 Nos
Area Classification	Zone 1&2	Plug Details	2 Blind Plug & 1 DC Cable gland 3/4"ET
Enclosure	Flameproof (Explosion proof) Ex-d		
Weight (approx)	12.0Kg		

## 2.2 Time Signal Input

Input	Description	Physical Interface
Serial RS485	<ul style="list-style-type: none"> <li>Protocols: NMEA-0183[RMC] / NGTS/ T – Format</li> <li>Baud Rate: 9600/19200</li> </ul>	Plug-in type Connector[Standard 4-pin MSTB Type] [Cable Size:2.5 sq.mm]
Serial RS232		
RF Wireless Input	<ul style="list-style-type: none"> <li>Wireless frequency: 866 MHz</li> <li><b>Line of site distance:</b> Approx 600 meters (Depends on Site Conditions)</li> </ul>	Wireless

## 2.3 Time Signal Output

Output	Description	Physical Interface
Serial RS485	<ul style="list-style-type: none"> <li>Protocols: NMEA-0183[RMC] (only Time and Date Parameter Present in frame other Parameter as indicated zero)</li> <li>Baud Rate: 9600/19200</li> </ul>	Same connector as Input
Serial RS232		
RF Wireless Output	<ul style="list-style-type: none"> <li>Wireless frequency: 866 MHz</li> <li><b>Line of site distance:</b> Approx 300 meters (Depends on Site Conditions)</li> </ul>	Wireless

**Note: If DDU-44/46 or DDU-TM-44/46[Wireless with Serial Model] is in sync using Serial [RS232/RS485] than do not use Serial [RS232/RS485] for Retransmission.**

### Isolation (Withstanding voltage)

- Between primary terminals\* and secondary terminals\*\*: At least 1500 V AC for 1 minute
- Between primary terminals\* and grounding terminal: At least 1500 V AC for 1 minute
- Between grounding terminal and secondary terminals\*\*: At least 1500 V AC for 1 minute

\* Primary terminals indicate power terminals

\*\* Secondary terminals indicate RS232/485.

**Insulation resistance:** 20MΩ or more @ 500 V DC between power terminals and grounding terminal



### 3. FRONT PICTURE

#### 3.1 DDU-44/DDU-TM-44 IP20 Front views:

Figure 1 Front View of DDU-44 IP20



Figure 2 Front View of DDU-TM-44 IP20



### 3.2 DDU-44/DDU-TM-44 IP20 (SS Front Plate) Front views:

Figure 3 Front View of DDU-44 IP20 (SS Front Plate)



Figure 4 Front View of DDU-TM-44 IP20 (SS Front Plate)



### 3.3 DDU-46/DDU-TM-46 IP20 Front views:

Figure 5 Front View of DDU-46 IP20



Figure 6 Front View of DDU-TM-46 IP20



**3.4 DDU-46/DDU-TM-46 IP20 (SS Front Plate) Front views:**

**Figure 7 Front View of DDU-46 IP20 (SS Front Plate)**



**Figure 8 Front View of DDU-TM-46 IP20 (SS Front Plate)**



### 3.5 DDU-44/DDU-TM-44 XP Front views:

Figure 9 Front View of DDU-44-XP



## 4. INSTALLATION & MOUNTING DETAIL

### 4.1 Safety Precautions in Installation



1. To minimize the possibility of fire or shock hazards, do not expose this instrument to rain or excessive moisture.
2. Do not use this instrument in areas under hazardous conditions such as excessive shock, vibration, dirt, moisture, corrosive gases or oil. The ambient temperature of the areas should not exceed the maximum rating specified.



Ground the device. Otherwise, it may cause an electric shock or fire.

The protective conductor terminal is marked with a label on the product terminals with the following symbol:



Also insure that Earth Ground of the premises has been done properly.



Be sure all personnel involved in installation, servicing, and programming are qualified and familiar with electrical equipment and their ratings

Do not install, store, or use it in the place with a lot of dust, corrosive and flammable gases, vibrations and shocks exceeding the allowed values, place low or high temperature outside of the installation condition, direct sunlight and near equipment generating strong radio waves or magnetic fields, It may cause accidents.

### 4.2 Wall Mount

- For DDU-TM-44/DDU-44 Wall mounting, there are two mounting clamp as shown in below drawing.

**Figure 10 Mounting detail for 4" 4 Digits [460mm x 175mm x 70mm] Enclosure (Wall Mount)**

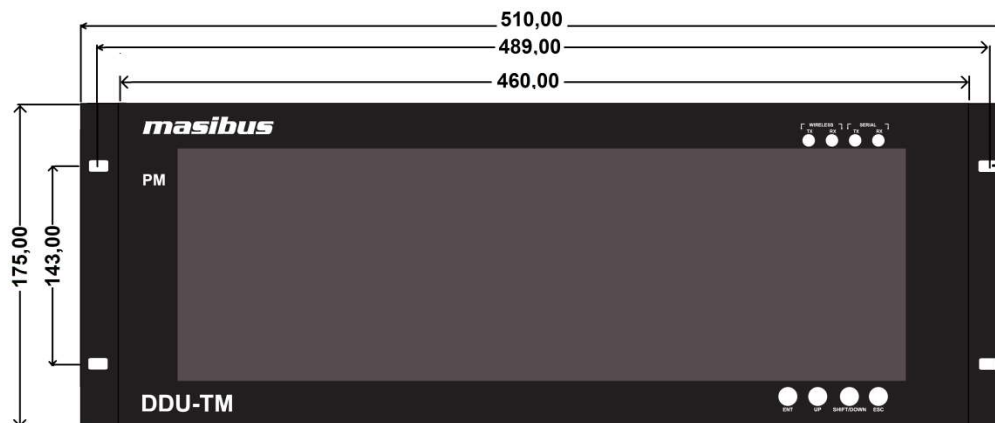

FRONT VIEW

- For DDU-TM-44/DDU-44 with SS Front Plate Wall mounting, there are two mounting Key hole in Bottom Part of Enclosure as shown in below drawing.

**Figure 11 Mounting detail for 4" 4 Digits [500mm x 215mm x 79mm] Enclosure (Wall Mount, SS Front)**

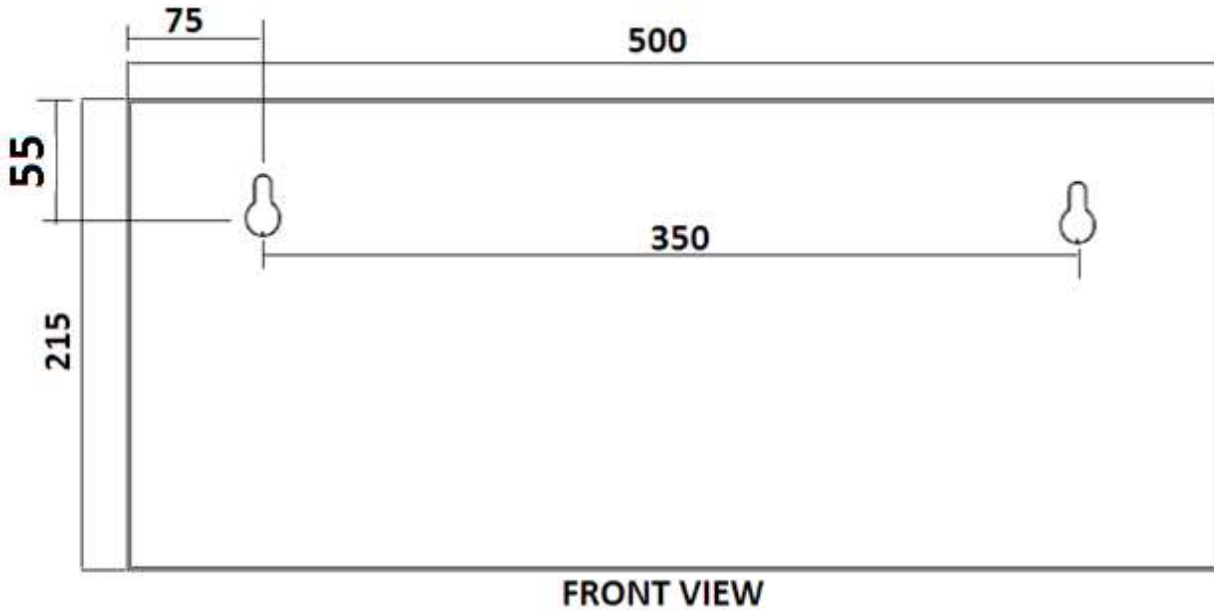

- For DDU-TM-46/DDU-46 Wall mounting, there are two mounting clamp as shown in below drawing.

**Figure 12 Mounting detail for 4" 6 Digits [665mm x 175mm x 70mm] Enclosure (Wall Mount)**

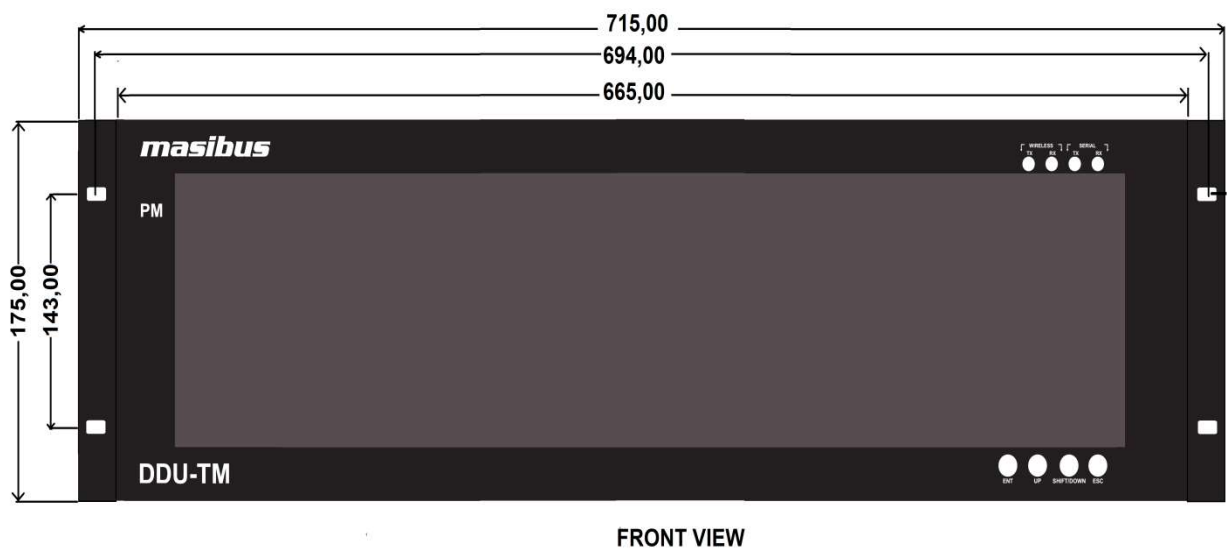

- For DDU-TM-44/DDU-44-XP Wall mounting, there are four mounting hole as shown in below drawing of Enclosure.

**Figure 13 Mounting detail for 4" 4 Digits [570mm x 260mm x 85mm] XP Enclosure**

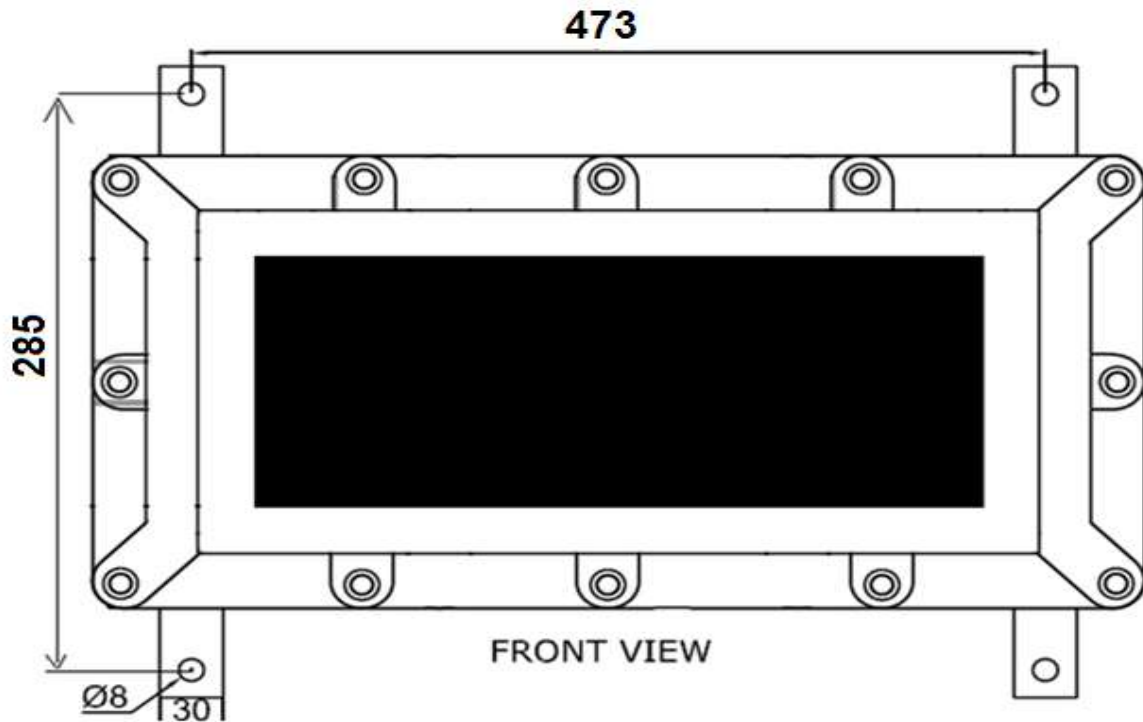

- For DDU-TM-46/DDU-46 with SS Front Plate Wall mounting, there are two mounting Key hole in Bottom Part of Enclosure as shown in below drawing.

**Figure 14 Mounting detail for 4" 6 Digits [705mm x 215mm x 79mm] Enclosure (Wall Mount, SS Front)**

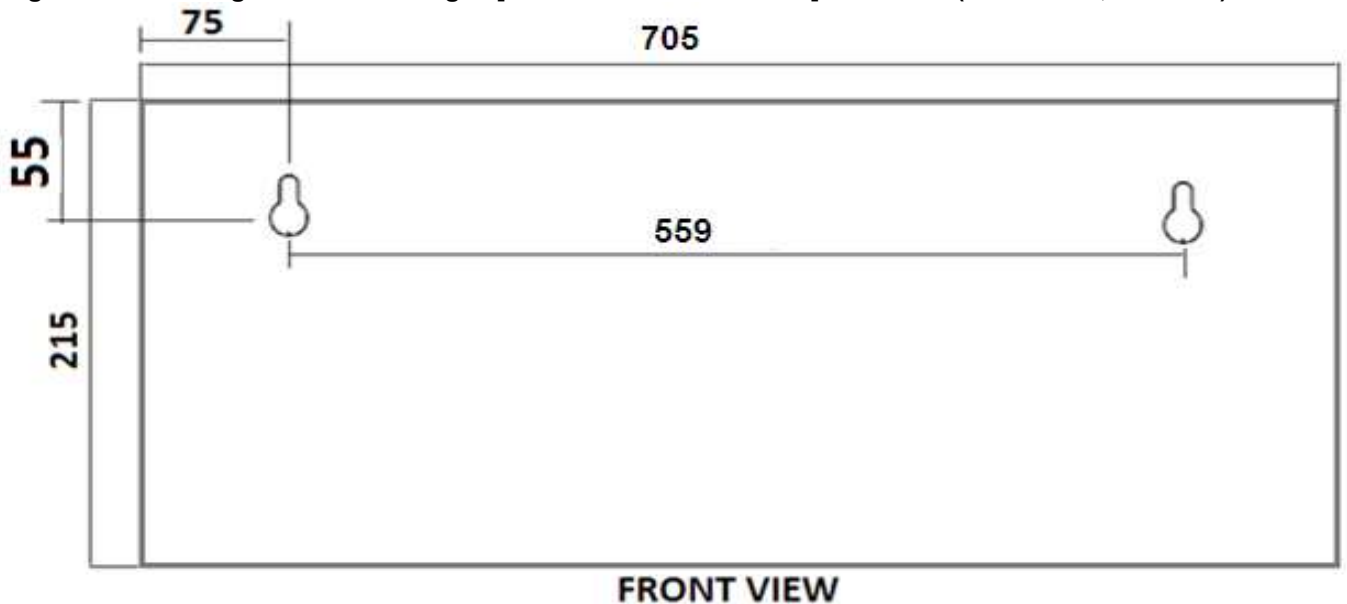



### 4.3 Panel Mount

- For DDU-TM-44/DDU-44 Panel mount two clamps are used for panel mounting as shown in below image

**Figure 15 Mounting detail for 4" 4 Digits [460mm x 175mm x 70mm] Enclosure (Panel Mount)**

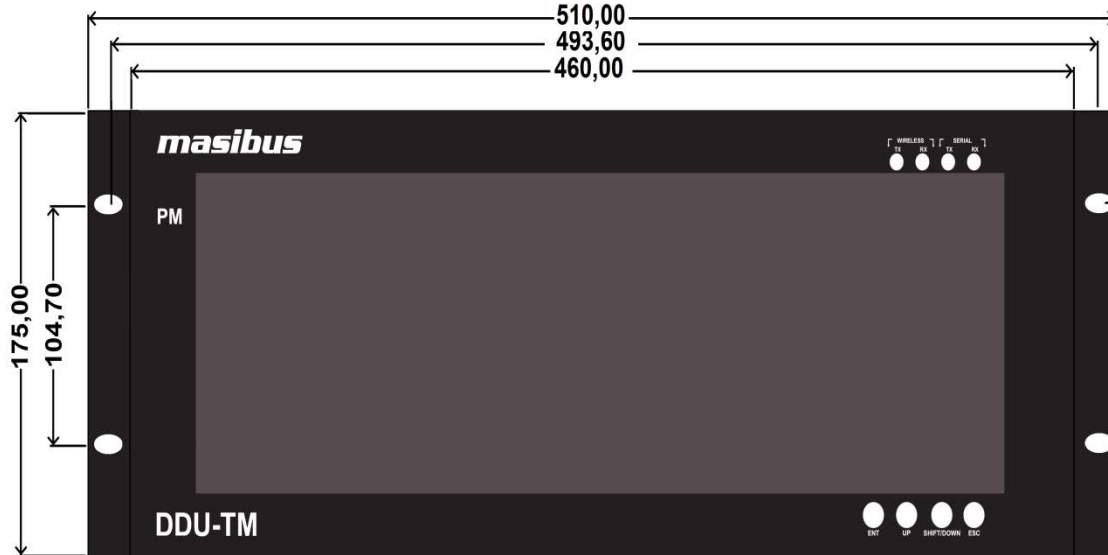

**FRONT VIEW**

- For DDU-TM-46/DDU-46 Panel mount two clamps are used for panel mounting as shown in below image

**Figure 16 Mounting detail for 4" 6 Digits [665mm x 175mm x 70mm] Enclosure (Panel Mount)**

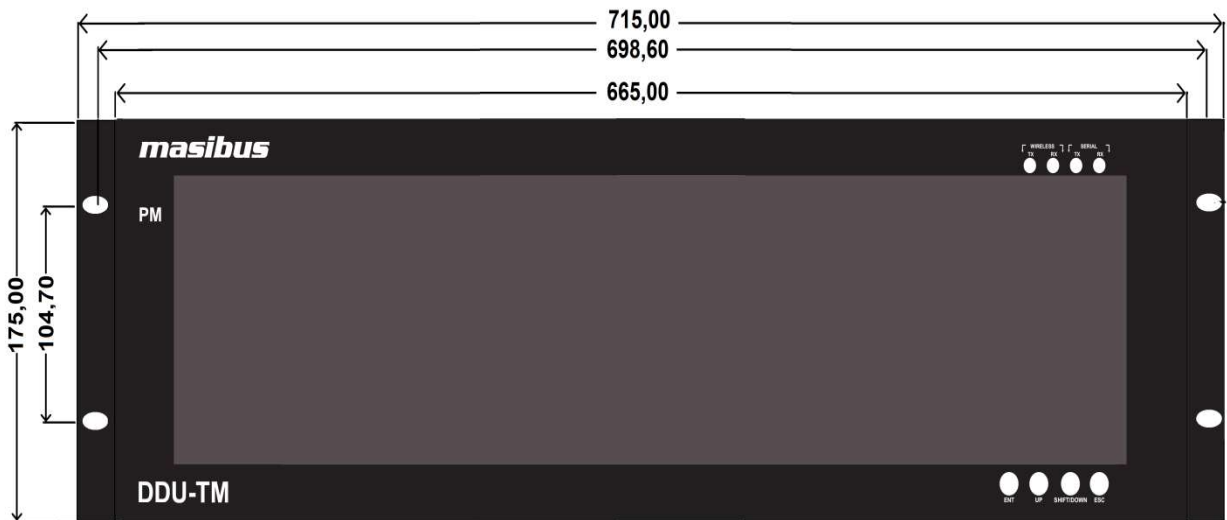

**FRONT VIEW**

#### 4.4 Flush Mount

- For DDU-TM-44/DDU-44 with SS Front Plate Flush mounting, there are four mounting hole in SS Front Plate as shown in below drawing.

**Figure 17 Mounting detail for 4" 4 Digits [500mm x 215mm x 79mm] Enclosure (Flush Mount)**

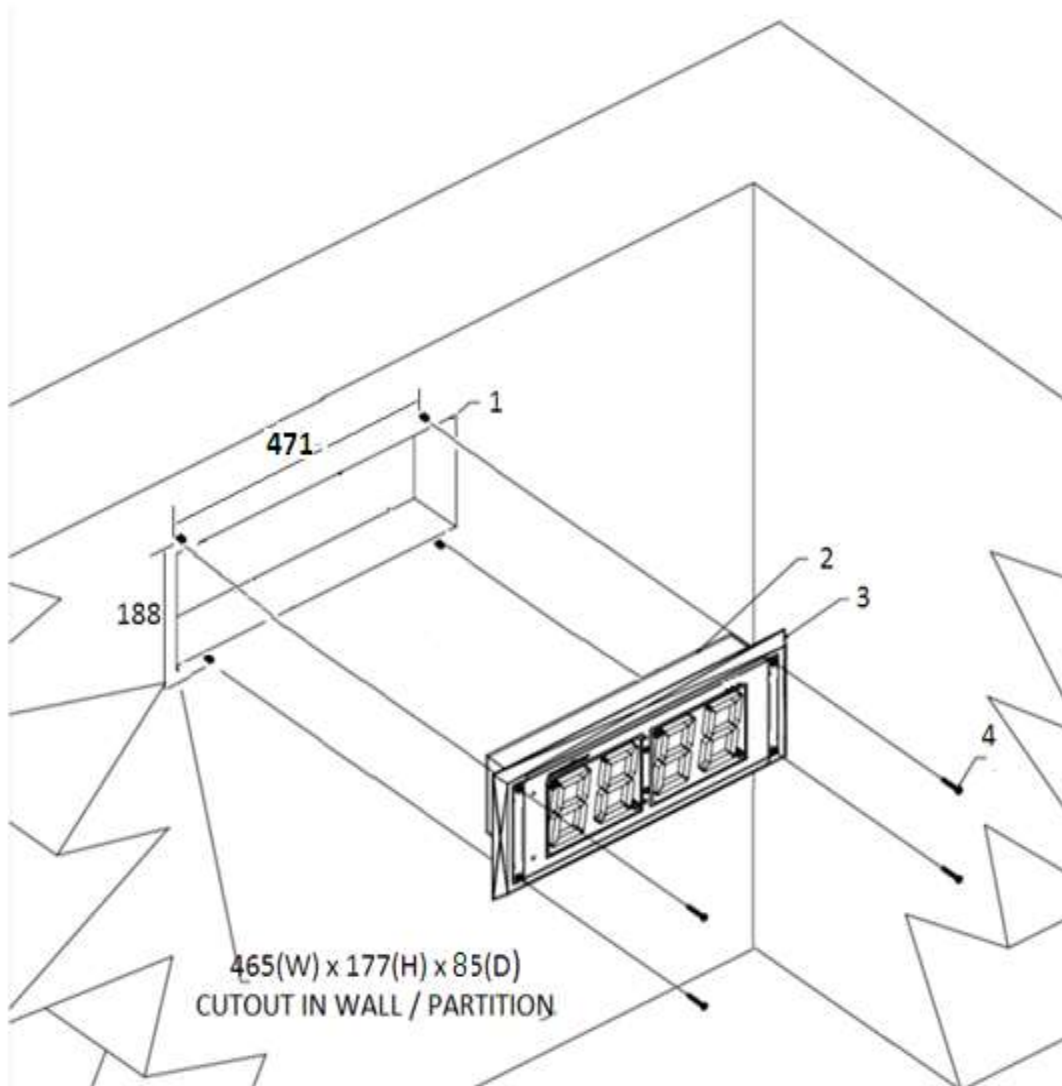

1. Cutout in Wall or Partition(Dimension:465(W) x 177(H) x 85(D))
2. DDU-TM-44/DDU-44 Instrument without Conceal Box
3. SS- Front Plate
4. Instrument mounting Self Thread screws 4 Nos.(Length 30mm)

Enclosure Dimension of DDU-TM-44/DDU-44 with SS Front Plate: 500mm (W) X 215mm (H) X 79mm (D)

- For DDU-TM-46/DDU-46 with SS Front Plate Flush mounting, there are Six mounting hole in SS Front Plate as shown in below drawing.

**Figure 18 Mounting detail for 4" 6 Digits [705mm x 215mm x 79mm] Enclosure (Flush Mount)**

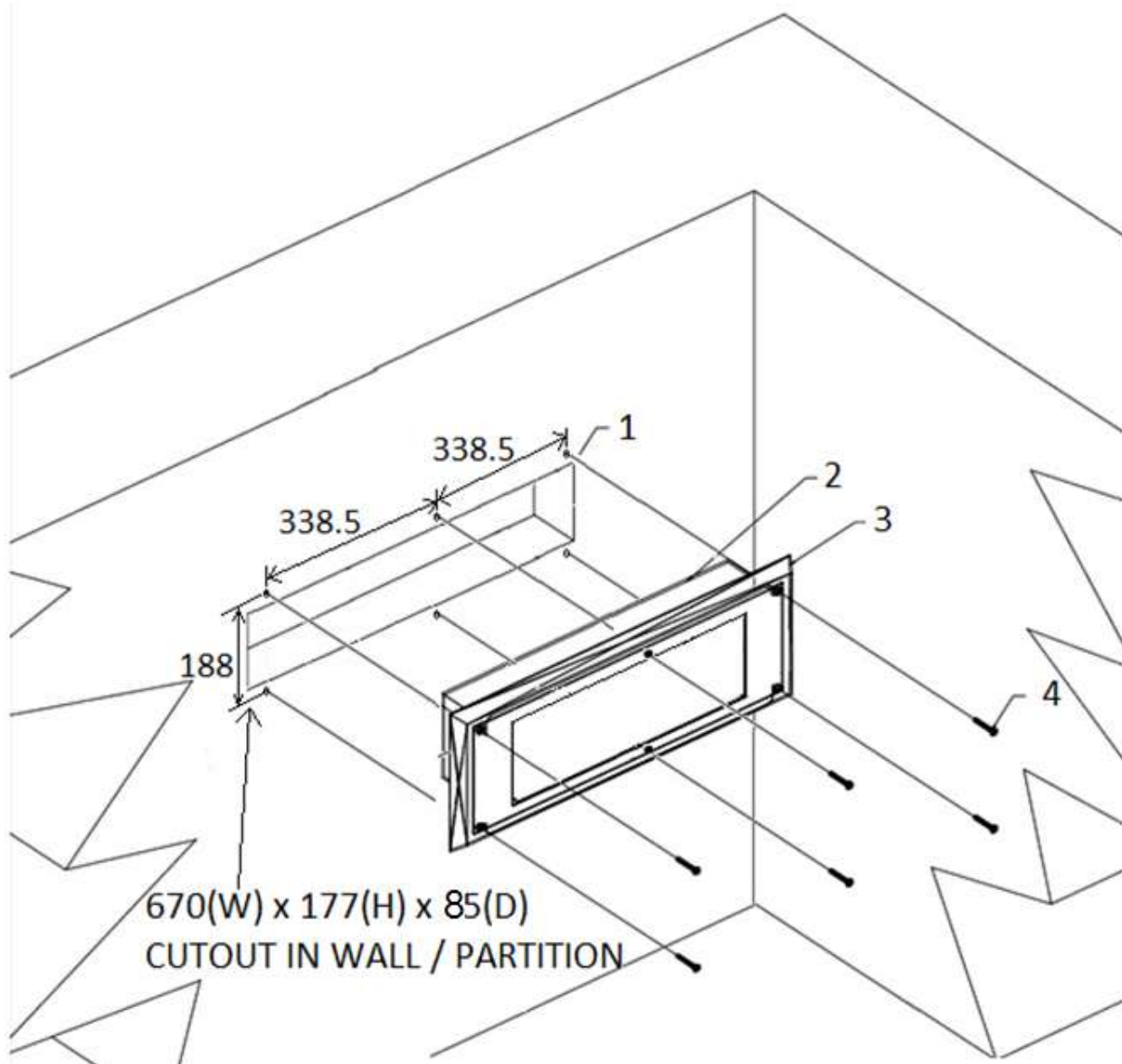

1. Cutout in Wall or Partition(Dimension:670(W) x 177(H) x 85(D))
2. DDU-TM-46/DDU-46 Instrument without Conceal Box
3. SS- Front Plate
4. Instrument mounting Self Thread screws 6 Nos.(Length 30mm)

Enclosure Dimension of DDU-TM-46/DDU-46 with SS Front Plate: 705mm (W) X 215mm (H) X 79mm (D).

## 5. TERMINAL CONNECTIONS

### 5.1 Terminal connections on DDU-TM-44/46 or DDU-44/46 Enclosures

#### 5.1.1 Terminal connection for Wall Mount Enclosure

Figure 19 Connection on Terminal plate of DDU-TM-44/46 or DDU-44/46 Wall Mount



Figure 20 Connections on Base Plate of DDU-44-XP (Wireless Model)

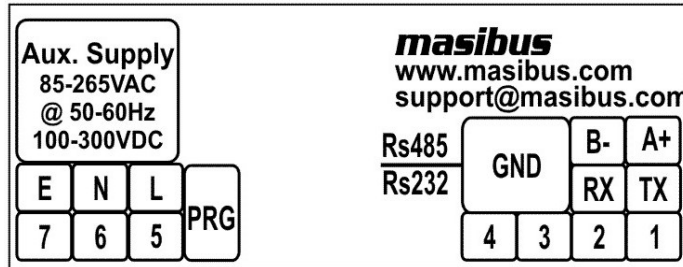

Figure 21 Connection on Terminal plate of DDU-TM-44/46 or DDU-44/46 [NTP Model]



Table 3 Terminal Connection Detail of Enclosures (Wall Mount)

No.	Terminal Type	Description								
1	MSTB Conn. 4 pin for RS232 or RS485	RS232 or RS485 serial data input								
		<table border="1"> <tr> <td>For RS232</td> <td>For RS485</td> </tr> <tr> <td>7 - TX</td> <td>7 - A+</td> </tr> <tr> <td>6 - RX</td> <td>6 - B-</td> </tr> <tr> <td>5 - GND</td> <td>5 - GND</td> </tr> <tr> <td>4 - GND</td> <td>4 - GND</td> </tr> </table>	For RS232	For RS485	7 - TX	7 - A+	6 - RX	6 - B-	5 - GND	5 - GND
For RS232	For RS485									
7 - TX	7 - A+									
6 - RX	6 - B-									
5 - GND	5 - GND									
4 - GND	4 - GND									
2	MSTB Conn. 3 pin for Aux. PWR.	<table border="1"> <tr> <td>3 - L</td> </tr> <tr> <td>2 - N</td> </tr> <tr> <td>1 - Earth</td> </tr> </table>	3 - L	2 - N	1 - Earth					
3 - L										
2 - N										
1 - Earth										
3	RJ45 Socket for NTP	For RJ45 based Ethernet connection for NTP[Network Time Protocol]								

### 5.1.2 Terminal connection for Panel Mount Enclosure

Figure 22 Connection on Terminal plate of DDU-TM-44/46 or DDU-44/46 Panel Mount

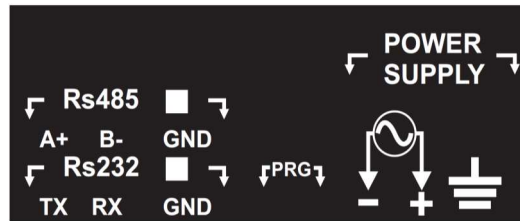

Table 4 Terminal Connection Detail of Enclosures (Panel Mount)

No.	Terminal Type	Description								
1	MSTB Conn. 4 pin for RS232 or RS485	RS232 or RS485 serial data input								
		<table border="1"> <tr> <td>For RS232</td> <td>For RS485</td> </tr> <tr> <td>1 - TX</td> <td>1 - A+</td> </tr> <tr> <td>2 - RX</td> <td>2 - B-</td> </tr> <tr> <td>3 - GND</td> <td>3 - GND</td> </tr> <tr> <td>4 - GND</td> <td>4 - GND</td> </tr> </table>	For RS232	For RS485	1 - TX	1 - A+	2 - RX	2 - B-	3 - GND	3 - GND
For RS232	For RS485									
1 - TX	1 - A+									
2 - RX	2 - B-									
3 - GND	3 - GND									
4 - GND	4 - GND									
2	MSTB Conn. 3 pin for Aux. PWR.	5 - L 6 - N 7 - Earth								
3	RJ45 Socket for NTP	For RJ45 based Ethernet connection for NTP[Network Time Protocol]								

## 5.2 How to connect wires

Before carrying out wiring, turn off the power and check that the cables to be connected are not alive because there is a possibility of electric shock.



### NOTE:

- ✓ All wiring must confirm to appropriate standards of good practice and local codes and regulations. Wiring must be suitable for Voltage, Current and temperature rating of the system.
- ✓ Provide power from a single-phase instrument power supply. If there is a lot of noise in the power line, insert an insulating transformer into the primary side of the line and use a line filter on the secondary side. Do not place the primary and secondary power cables close to each other.
- ✓ Use repeater after each set of 32 instruments connected in RS-485 Communication.
- ✓ Unused terminals should not be used as jumper points as they may be internally connected, which may cause damage to the unit.
- ✓ Use >250V-1Amp Cable for Power Supply.
- ✓ Supply voltage must be below maximum voltage rating specified on the label.

**Figure 23 RS232 Connection Details**

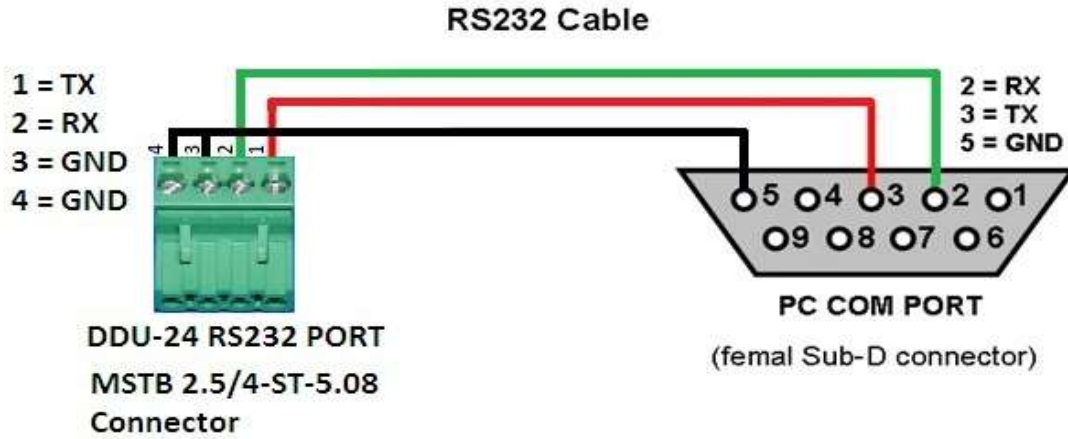

**Figure 24 RS485 Connection Details**

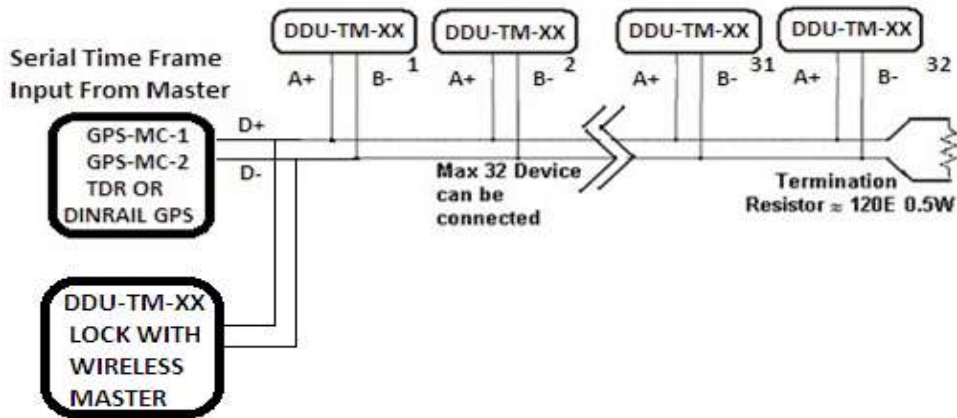

Note: - Consider RS485 Connection Detail for DDU-TM-44/DDU-44 or DDU-TM-46/DDU-46 same as above figure 15

- ✓ In case of RS-232 Output base master unit, external RS-232 to RS-485 Connector required, and it will be connected direct in case of RS-485 output from Master.

**Figure 25 NTP + PoE connection Detail**

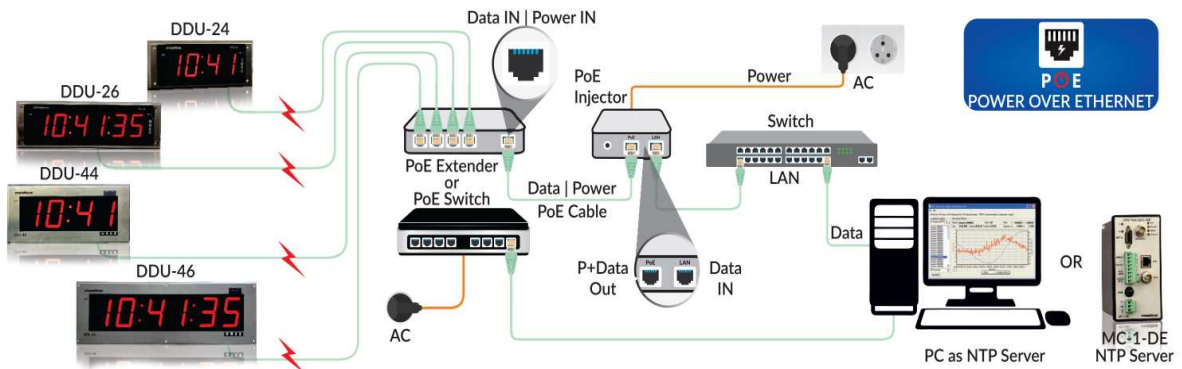

**Installation Process for Flame Proof Enclosure:**

1. Open the Front cover of Flame Proof Enclosure using Allen Key No:-6.
2. Open the Screw mounted which are specified for wiring connection on display PCB.
3. Move PCB upward. Pass the Power cable and Serial connector cable from the Gland. Make the connection according to Terminal connection describe in 5.1 sections
4. After connecting a cable and Serial connection as per connection details. Mount PCB back on stud as before.
5. After that Power ON the unit.
6. Configure the unit as per your Requirement with help of Keys on PCB, for configuration details please refer section.
7. After successful configuration close the front cover using Allen key and mount it on the wall.

## 6. CONFIGURATION GUIDELINES

### 6.1 Default Configuration

➤ A DDU-TM-44/46 or DDU-44/46 ships from the factory with following configuration.

- Display Type : Time Display
- Time Format : Hour Time Format 24
- Date Format : DD.MM
- Time Zone Offset : 05:30

Applicable for Serial Input Model:

- Baud Rate : 9600
- Stop Bit : 1
- Parity Bit : None

Applicable for Wireless Input Model:

- RFM Receive Channel : 0

- Display Unlock Blink : BL.10
- Password : 0001
- Retransmission : No
- Slave ID : XXXX[Between 0001 to 9998]
- Default Ethernet configuration(For NTP or NTP + PoE Input Model)

IP Address	: 192.168.100.032
Subnet mask	: 255.255.255.000
Gateway	: 192.168.100.001
Primary Server IP Address	: 192.168.100.153
Secondary Server IP Address	: 192.168.100.154
Query Interval Time [When Querying NTP Server]	: 0016
Query Request Time out	: 02
Query Retry Interval	: 02
Number of Time outs before switching Servers	: 03
Secondary Server Option for NTP	: Disable
SNMP Manager IP1	: 192.168.100.226
SNMP Manager IP2	: 192.168.100.226
SNMP Write Community	: masibus
SNMP Read Community	: masibus

#### **Note:**

1. Fundamental operation mode (Display Settings) will come in affect immediately of SW change. Action of CONFIG can be switched during clock operation. No power on/off cycle is required to change these modes.
2. Default Setting of DDU-TM-46/DDU-46 Same as above configuration but only change in Date Format. In DDU-TM-46/DDU-46 date Format is DD.MM.YY by Default.
3. Default Setting of DDU-TM-44/46 or DDU-44/46 with NTP or NTP +PoE Same as above configuration but only change in Display Unlock Blink and Retransmission. In Display Unlock Blink is BLON. Slave ID, Wireless configuration and Retransmission Features not available. Ethernet Default configuration available for this model only. Please ignore the Serial Parameter in Default configuration menu if DDU-TM-44/46 or DDU-44/46 has order with only NTP or PoE option. The configuration can be done through Telnet for this Option.
4. For NTP Use RJ-45 cross cable when connecting DDU-TM-44/46 or DDU-44/46 directly with GPS Master Clock. Use RJ-45 straight cable when connect DDU-TM-44/46 or DDU-44/46 through switch.
5. In DDU-TM-44/46 or DDU-44/46 Wireless unit, you can see the unlock status as Blinking colon or whole display. By default it show a unlock status by blinking colon and DP in Time and Date. It can send the Trap of Lock and Unlock status to SNMP manager IP address In NTP Clock.
6. Slave ID of Unit is set in Factory once. You can set Slave Id by Entering in Configuration Menu. Slave ID will not change in Default Condition. These Feature available in Wireless unit.



## 6.2 Key Configuration:

**DDU-TM-44/46 or DDU-44/46** offers facility to the users for configuring communication parameters of serial port, Display Format Selection, Time Zone Selection, Manual Time Set, Set Default Parameter, Retransmission selection and View Current Settings by Key Configuration or using serial for NTP Model

- The communication parameters include baud rate, number of stop bits and parity.
- User Can Set Manual Time if no availability of Time Inputs.
- The user is free to choose Time Display, Date Display and Both in Alternate Time/Date Display.
- User can set any Standard Time Zone Offset, in any Input like Wireless and Serial.
- The user can enter the time offset of the time zone, where the unit is to be installed.
- Users can set Default all Configuration Parameter and View Current Configuration Parameter using Key Configuration.
- The user can set the Retransmission using RF, Serial or Both.
- User can set blinking of Date DP and Time Display Colon or Whole Display of Time and Date in unlock condition.
- In Ethernet Configuration, User can set, IP, MASK, GATEWAY, SUBNET, Primary Server IP, Secondary Server IP, NTP Query Interval Time [When Querying NTP Server] , Query Request Time Out , Query Retry Interval , Number of Time outs Before switching Servers, Secondary Server Option For NTP,SNMP Manger IP addresses and Its write and Read community.

### 6.2.1 Run Mode

- As Shown in Fig 24 DDU-TM-44/46 or DDU-44/46, will display Time or Date as per set parameter in Run mode.

### 6.2.2 Password Mode (PSWD): `PSWD`

- To enter in Password mode long press Enter key for 4 Seconds, it will show `PSWD` in Display. Enter Password using UP, Shift and Enter Keys, DDU-TM-44/46 or DDU-44/46 will enter in Configuration mode and Display `DISP` on Display.

### 6.2.3 Configuration Mode

#### 6.2.3.1 Display Configuration Mode (DISP): `DISP`

- Press Enter Key to Enter in Display mode, it will enter in View mode and shows Current Display Mode.
- Press Enter in View mode to enter in Edit mode , in Edit mode it will shows `Time` , `Date` and `Both` mode , Press Enter key to set the any Display mode.
- Time mode will display time in Run mode, Date mode will display Date in Run mode and both option will Display Time and Date Both, Date will be displayed at seconds 18-20, 38-40, and 57-60 of minute.

#### 6.2.3.2 Time Mode Set Configuration (T-MD): `T-MD`

- Press Enter Key to Enter in Time mode, it will enter in View mode and shows Current Time Mode.
- Press Enter in View mode to enter in Edit mode , in Edit mode it will shows `12HR` for 12 hour time format and `24HR` for 24 hour time format , Press Enter key to set the any One Time mode.

#### 6.2.3.3 Date Mode Set Configuration (D-MD): `D-MD`

- Press Enter Key to Enter in Date mode, it will enter in View mode and shows Current Date Mode.
- Press Enter in View mode to enter in Edit mode, in Edit mode it will shows `DDMM` and `MMDD` Date format in DDU-TM-44 or `ddmmyy`, `mmddyy` and `yyymmdd` in DDU-TM-46, Press Enter key to set the any One Date mode.

**6.2.3.4 Manual Time Set Configuration (S-TM): S-tñ**

- Press Enter Key to Enter in Manual Time Set mode, it will enter in View mode and shows Current Time on Display.
- Press Enter in View mode to enter in Edit mode, in Edit mode Set time using INC and SHIFT Keys, Press Enter key to set the Time.

**Figure 26 Display and Key Configuration Detail**

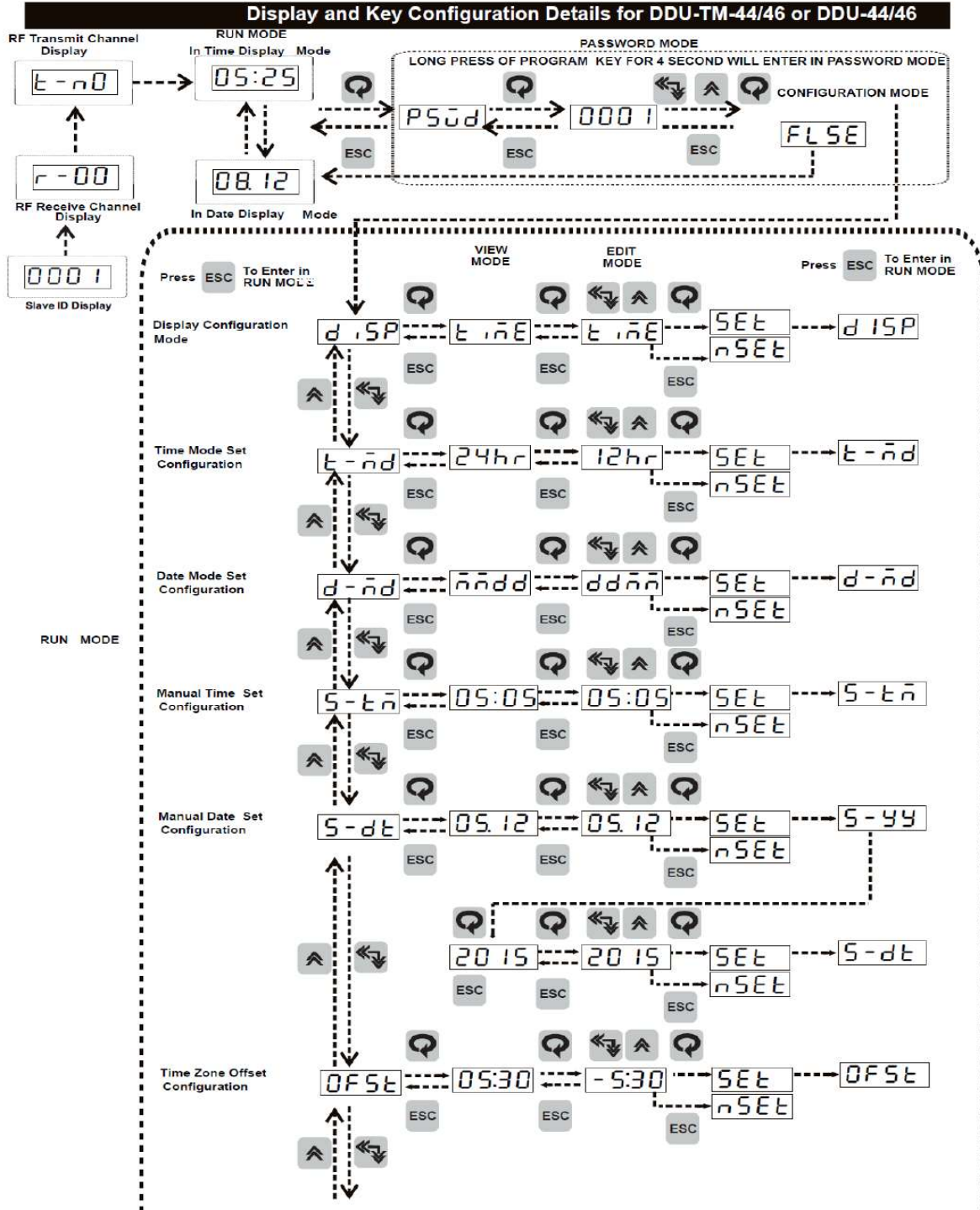

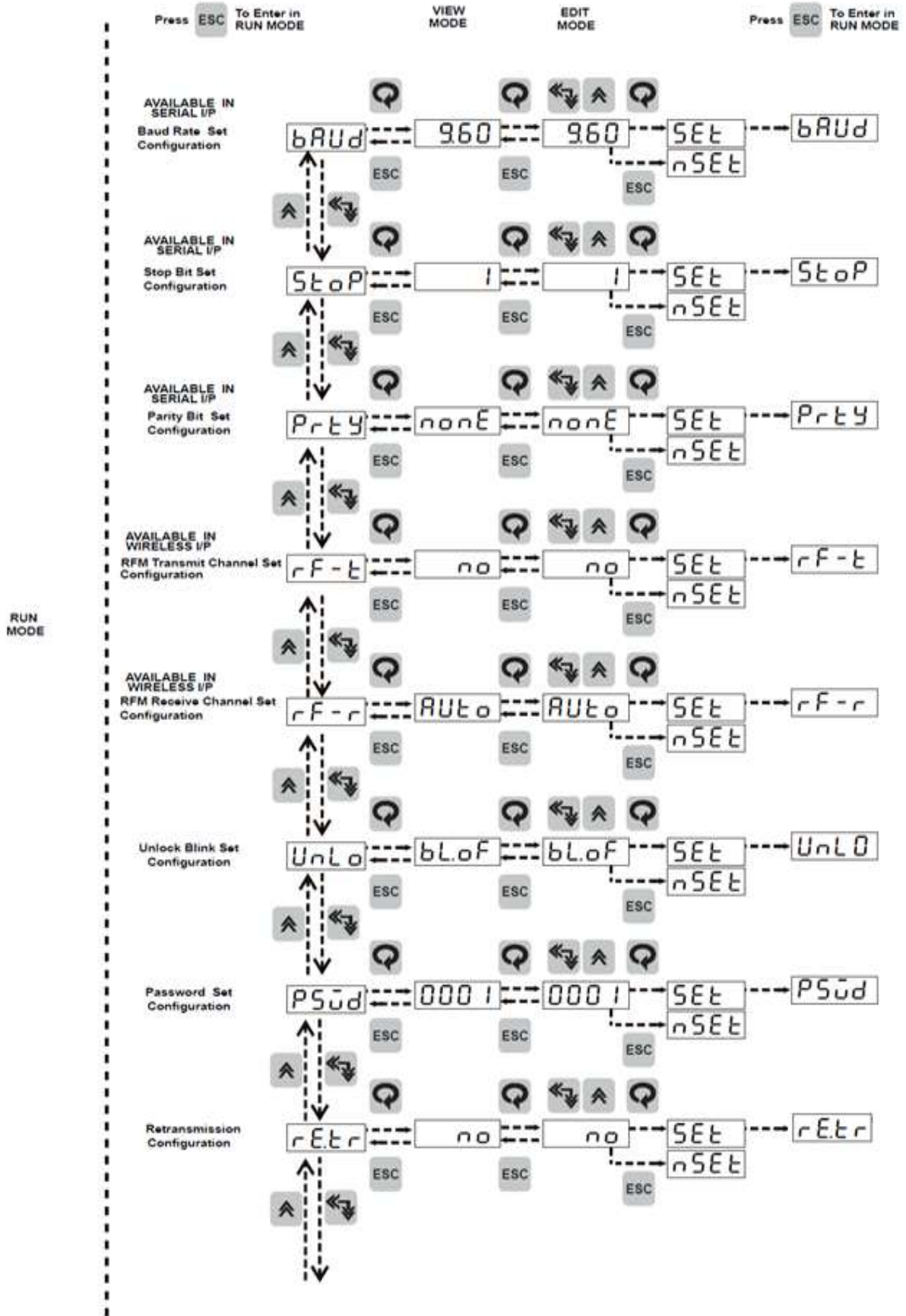

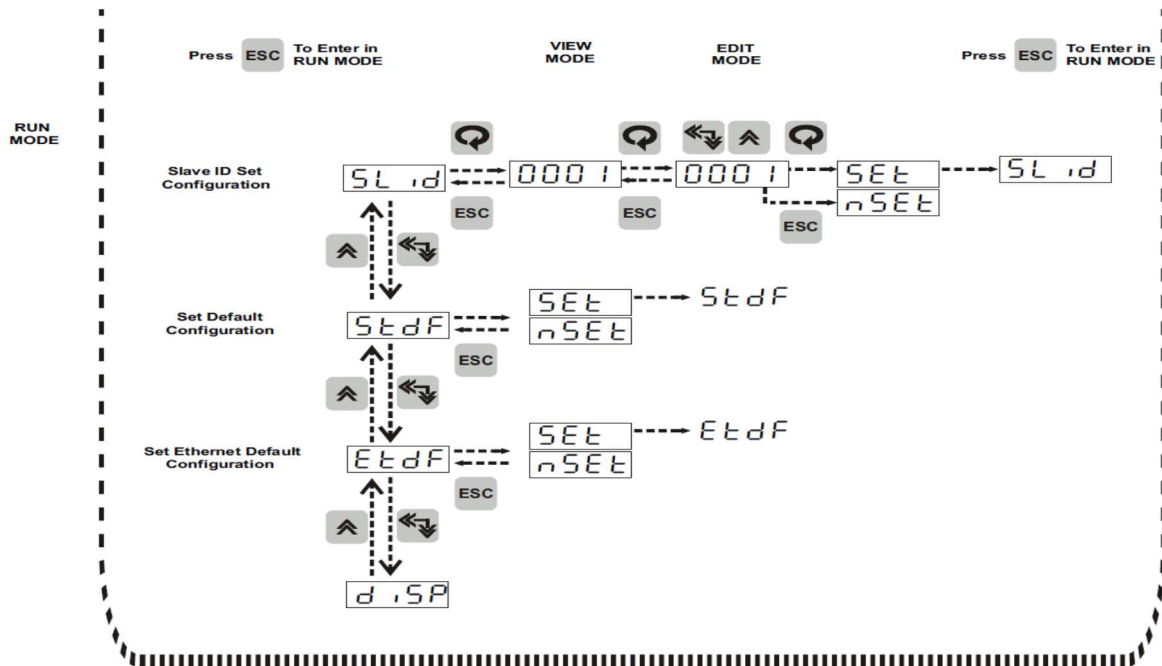

**Note:** - Figure 25 Display the Key configuration of DDU-TM-44/DDU-44. In DDU-TM-46/DDU-46 Key configuration same as DDU-TM-44/DDU-44 but only Change in date format configuration.

- The Date format given for Display
  - For DDU-TM-44/DDU-44:
    1. DD/MM
    2. MM/DD
  - For DDU-TM-46/DDU-46
    1. DD/MM/YY
    2. MM/DD/YY
    3. YY/MM/DD

➤ **Wireless Input model:**

- First power on unit it will display Slave ID, RF receive channel 0 then it will start to display Time in default condition that are set in unit.
- If you are already set RF transmit channel and then after unit power on it will display RF receive channel and RF transmit channel that you are set. Then it will start to run mode display.
- If you are select Auto mode in RF receive channel and then after unit power on it will display RF receive channel which unit previous lock in auto mode.
- This feature is only available in wireless input model.
- Configuration done by master GPS-MC-2 over wireless is only available in Wireless input Model.

➤ **Serial Input model:**

- First power on unit it will display Slave ID then it will start to display Time in default condition that are set in unit.

➤ **NTP or NTP + PoE input Model:**

- First Power on Unit it will start to Display Time in default condition that are set in Unit
- In this model Salve ID, wireless parameter configuration and retransmission Features are not available.
- For lock unlock only Blinking ON and OFF option is available, in case of Blink ON it will blink after 59 second if it is unlocked.
- Ethernet Default configuration is available for this model only.
- Please ignore the Serial Parameter in configuration menu if DDU-24/26 has order with only NTP or PoE option. The configuration can be done through Telnet for this Option.

- Serial Port can be used for Configuration or Time sync.

#### 6.2.3.5 Manual Date Set Configuration (S-DT): S-DT

- Press Enter Key to Enter in Manual Date Set mode, it will enter in View mode and shows Current Date on Display.
- Press Enter in View mode to enter in Edit mode, in Edit mode set date using INC and SHIFT Keys, Press Enter key to set the date it will show **S-YY** option on display to set year, Press Enter key to set the year.

#### 6.2.3.6 Time Zone Configuration (OFST): OFST

- Press Enter Key to Enter in Time Zone offset mode, it will enter in View mode and shows Current Time Zone offset on Display.
- Press Enter in View mode to enter in Edit mode, in Edit mode set time Zone offset using INC and SHIFT Keys, Press Enter key to set the Time Zone offset.
- Please enter time zone between +12:00 to -12:00 International standard.

#### 6.2.3.7 Baud Rate Set Configuration (BAUD): BAUD

- Press Enter Key to Enter in Baud rate Set mode, it will enter in View mode and shows Current Baud rate on Display.
- Press Enter in View mode to enter in Edit mode, in Edit mode Set Baud rate using INC and SHIFT Keys, Press Enter key to set the Baud Rate.
- In Edit mode it will show two options 9.60 for 9600 and 1.920 for 19200 baud Rate.

#### 6.2.3.8 Stop Bit Set Configuration (STOP): STOP

- Press Enter Key to Enter in Stop Bit Set mode, it will enter in View mode and shows Current Stop Bit on Display.
- Press Enter in View mode to enter in Edit mode, in Edit mode Set Stop Bit using INC and SHIFT Keys, Press Enter key to set the Stop Bit.
- In Edit mode it will show two options 1 for 1 Stop Bit and 2 for 2 Stop Bit.

#### 6.2.3.9 Parity Bit Set Configuration (PRTY): PRTY

- Press Enter Key to Enter in Parity Bit Set mode, it will enter in View mode and shows Current Parity Bit on Display.
- Press Enter in View mode to enter in Edit mode, in Edit mode Set Parity Bit using INC and SHIFT Keys, Press Enter key to set the Parity Bit.
- In Edit mode it will show three options **odd** Parity, **Even** Parity and **none** Parity.

#### 6.2.3.10 RF Transmit Channel Set Configuration (RF-T): RF-T

- This Option only available in Wireless Input Model for Retransmission of Received Signals for increasing the Range.
- In Wireless input Model this option is available when in Retransmission configuration (**re.tr**) you are selecting **pp** or **both** for Retransmission of Received Signals for increasing the Range and also selecting receive channel between 0 to 9 except Auto mode in **RF-r** for RF receive channel set configuration.
- Press Enter Key to Enter in RF Transmit Channel Set mode, it will enter in View mode and shows Current RF Transmit Channel on Display.
- Press Enter in View mode to enter in Edit mode, in Edit mode Set RF Transmit Channel using INC Key, Press Enter key to set the RF Transmit Channel.
- In Edit mode it will show 0-9 and no options, **no** option for no re-transmission, It will stop re-transmission.
- When the unit is Transmitting RF Time Frame at that time wireless Tx Led glow.
- You can show the RF transmit channel at power on.

- If you are select Auto mode in RF receive channel and then after unit power on it will display RF receive channel which unit previous lock in auto mode.

#### 6.2.3.11 RF Receive Channel Set Configuration (RF-R): r F - r

- This Option only available for Receiving Signals from Wireless master or Wireless Re-Transmitter.
- Press Enter Key to Enter in RF Receive Channel Set mode, it will enter in View mode and shows Current RF Receive Channel on Display.
- Press Enter in View mode to enter in Edit mode, in Edit mode Set RF Transmit Channel using INC Key, Press Enter key to set the RF Receive Channel.
- In Edit mode it will show 0-9 and **Auto** options.
- Auto mode is disabled when you are selecting **RF** and **BOTH** option in retransmission configuration.
- Auto mode is enabled when you are selecting **no** and **ser** in retransmission configuration.
- In Auto mode DDU-TM-44/46 or DDU-44/46 will scan RF channel between 0 to 9 for Receiving RF Signals from Wireless master Time Signal provider.
- When unit receive RF Time Frame at that time Wireless Rx Led glow.
- You can show the RF receive channel at power on.

#### 6.2.3.12 Unlock Blink Set Configuration (UNLO): UnLO

- This option will used in unlock condition, if you want stop blinking of Colon in Time Display and DP in Date Display.
- Press Enter Key to Enter in Unlock Blink mode, it will enter in View mode and shows Current Unlock Blink Mode.
- Press Enter in View mode to enter in Edit mode , in Edit mode it will shows **BL.0f** to stop blinking and **BL.02**, **BL.05** and **BL.10** to blink colon and DP in unlock condition and **BLDI** for whole Display Blink, Press Enter key to set the any One Blinking option.
- User can set time to start Blinking colon and DP or Whole Display in unlock condition when the unit is not synchronize or receive Time frame Input from the master within the configurable time.
- User can set configurable time 2 second, 5 second or 10 second by setting option **BL.02**, **BL.05** and **BL.10** respectively.
- If User set **BLDI** option then unlocks timeout will be 2 minute.
- By default unlock blinking time is 10 second.

#### 6.2.3.13 Password Set Configuration (PSWD): PSWd

- Press Enter Key to Enter in Password mode, it will enter in View mode and shows Current Password on Display.
- Press Enter in View mode to enter in Edit mode, in Edit mode set password using INC and SHIFT Keys, Press Enter key to set Password.

#### 6.2.3.14 Retransmission configuration (RE.TR): rE.tr

- Press Enter Key to Enter in Retransmission, it will enter in View mode and shows Current configuration of Retransmission.
- Press Enter in View mode to enter in Edit mode, in Edit mode set configuration of Retransmission using INC and SHIFT Keys, Press Enter key to set the Retransmission.
- In Edit mode it will show four options **no**, **rf**, **ser** and **both**. If unit is serial and wireless input model.
- Press Enter key to set retransmission.
- It transmits time of its internal RTC using RF and Serial.

- In Pφ-τ configuration No option selected by default if receive channel in ρφ-ρ configuration and transmit channel in ρφ-τ configuration are same and If you are In Retransmission configuration for selecting Σερ or βοτη option.
- If unit is only serial Input Model then only two option vo or σερ available in Retransmission configuration.
- If unit is only wireless Input Model then only two option vo or ρφ available in Retransmission configuration. If you are select Auto mode in RF receive channel configuration then no option is available in retransmission mode.
- If you are select Auto mode in RF receive channel configuration then no and ser option is available in retransmission mode for wireless and serial input model.
- When it Transmit RF or Serial Time Frame at that time Wireless or Serial Tx Led glow.
- When it Receive RF or Time Frame at that time Wireless or Serial RX Led glow respectively.
- If DDU-TM-44/46 or DDU-44/46 is in sync using Serial [RS232/RS485] than do not use Serial [RS232/RS485] for Retransmission.

#### 6.2.3.15 Slave ID configuration: SL id

- Press Enter Key to Enter in Slave ID configuration, it will enter in View mode and shows Current Slave ID of Unit.
- Press Enter in View mode to enter in Edit mode, in Edit mode set Slave ID using INC and SHIFT Keys, Press Enter key to set Slave ID.

#### 6.2.3.16 Set Default Configuration (STDF): STdF

- Press Enter Key to set the default parameters and Default parameter as per below.
  - Display Type : Time Display
  - Time Format : Hour Time Format 24
  - Date Format : DD.MM
  - Time Zone Offset : 05:30

Applicable for Serial Input Model:

- Baud Rate : 9600
- Stop Bit : 1
- Parity Bit : None

Applicable for Wireless Input Model:

- RFM Receive Channel : 0
- Display Unlock Blink : BL.10
- Password : 0001
- Retransmission : No
- Slave ID :XXXX[Between 0001 to 9998]

#### 6.2.3.17 Set Ethernet Parameter Default Configuration of Ethernet (STDF): ETdF

- Press Enter Key to set the default parameters of Ethernet and Default parameter as per below.
  - Default Ethernet configuration(For NTP or NTP + PoE Input Model)
    - IP Address : 192.168.100.032
    - Subnet mask : 255.255.255.000
    - Gateway : 192.168.100.001
    - Primary Server IP Address : 192.168.100.153
    - Secondary Server IP Address : 192.168.100.154
    - Query Interval Time [When Querying NTP Server] : 0016
    - Query Request Time out : 02
    - Query Retry Interval : 02
    - Number of Time outs before switching Servers : 03
    - Secondary Server Option for NTP : Disable
    - SNMP Manager IP1 : 192.168.100.226
    - SNMP Manager IP2 : 192.168.100.226

SNMP Write Community : masibus  
SNMP Read Community : masibus

**Note:-**

1. Default Setting of DDU-TM/46 or DDU-46 Same as above configuration but only change in Date Format. In DDU-TM/46 or DDU-46 date Format is DD.MM.YY by Default.
2. Default Setting of DDU-TM-44/46 or DDU-44/46 with NTP or NTP +PoE Same as above configuration but only change in Display Unlock Blink and Retransmission. In Display Unlock Blink is BLON. Slave ID, Wireless configuration and Retransmission Features not available. Please ignore the Serial Parameter in Default configuration menu if DDU-24/26 has order with only NTP or PoE option. The configuration can be done through Telnet for this Option.
3. Ethernet Default configuration available for NTP or NTP + PoE model only.
4. In DDU-TM-44/46 or DDU-44/46 Wireless unit, you can see the unlock status as Blinking colon or whole display. By default it show a unlock status by blinking colon and DP in Time and Date. It can send the Trap of Lock and Unlock status to SNMP manager IP address in NTP Clock.
5. Slave ID of Unit is set in Factory once. You can set Slave Id by Entering in Configuration Menu. Slave ID will not change in Default Condition.

**6.2.4 Configuration command through Telnet**

**6.2.4.1 For the First Time setup follow the below procedure.**

1. Masibus DDU-TM-44/46 or DDU-44/46 Display Unit has default network settings as mentioned in **Section 6.1**, First connect the Display Unit direct with local computer using a **cross** cable. (Not in Network)
2. Make the computer IP 192.168.100.XXX (XXX is any value between 1 to 255)
3. Ping the Display Unit IP & response must come from it. Now follow the below commands to configure the Display Unit.  
To check ping command open run window & enter **ping xxx.xxx.xxx.xxx -t** command where xxx.xxx.xxx.xxx means the IP of DDU-TM-44/46 or DDU-44/46.

**6.2.4.2 Network settings using windows as TELNET client.**

1. Open command prompt.

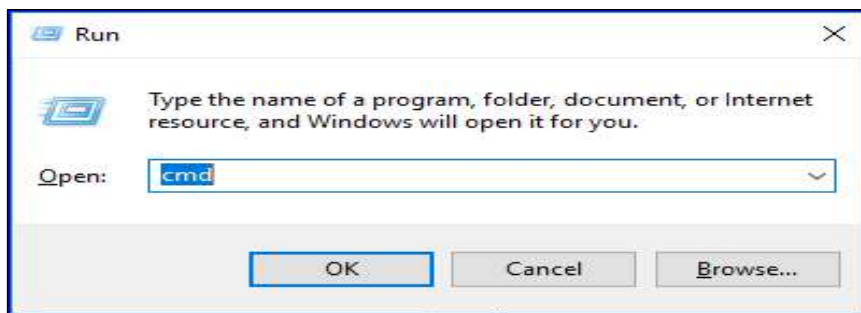

2. Enter Telnet and press Enter.

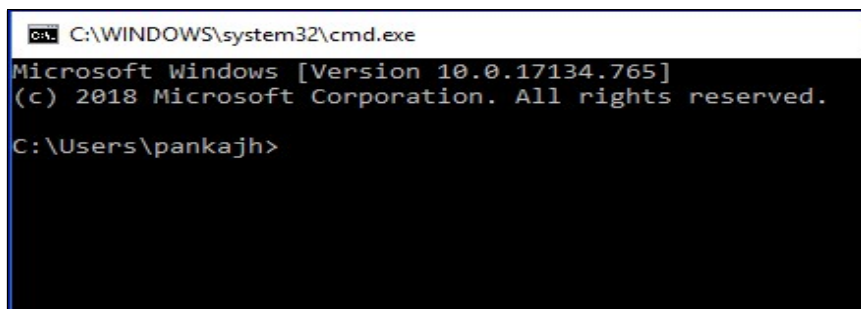



3. Enter “open 192.168.100.32” and press Enter.

```
cmd Command Prompt - telnet
Welcome to Microsoft Telnet Client
Escape Character is 'CTRL+]'
Microsoft Telnet> open 192.168.100.32_
```

4. Following screen will be displayed.

```
cmd Telnet 192.168.100.32
*****
Masibus Telnet Server
*****
Login: _
```

5. Enter Login-name and press enter. Enter password and press enter. Login-name and password both are case sensitive. **Default Login- name and password both are “masibus”.**

```
cmd Telnet 192.168.100.32
*****
Masibus Telnet Server
*****
Login:masibus
Password:
Logged in successfully
Press 'q' to Logout.
Press 'h' for help.
Press eth0 for Ethernet configurations.
```

6. IP
- This command is used to change **IP address** of DDU-TM-44/46 or DDU-44/46.
  - IP address should be entered in **xxx.xxx.xxx.xxx** form.
  - Enter new IP address and press enter. To save the new IP address Press 'Y' else press 'N'. If you press **Y** new IP address will be saved and if you press **N** the previous IP address will be retained.
  - IP address of DDU-TM-44/46 or DDU-44/46 is 192.168.100.032 by default.

```
CA> Telnet 192.168.100.32
*****
Masibus Telnet Server
*****

Login:masibus
Password:
Logged in successfully

Press 'q' to Logout.
Press 'h' for help.
Press eth0 for Ethernet configurations.

IP
Enter IP address:192.168.100.32

Command complete,
To save changes press 'Y' else press 'N':Y
Command complete

Press 'q' to Logout.
Press 'h' for help.
Press eth0 for Ethernet configurations.
```

## 7. MASK

- This command is used to change **Subnet Mask** of DDU-TM-44/46 or DDU-44/46.
- Subnet Mask should be entered in **xxx.xxx.xxx.xxx** form.
- Enter new Subnet Mask and press enter. To save the new Subnet Mask Press '**Y**' else press '**N**'. If you press **Y** new Subnet Mask will be saved and if you press **N** the previous Subnet Mask will be retained.
- Subnet Mask of DDU-TM-44/46 or DDU-44/46 is 255.255.255.0 by default.

```
CA> Telnet 192.168.100.32
*****
Masibus Telnet Server
*****

Login:masibus
Password:
Logged in successfully

Press 'q' to Logout.
Press 'h' for help.
Press eth0 for Ethernet configurations.

MASK
Enter Subnet mask:255.255.255.0

Command complete,
To save changes press 'Y' else press 'N':Y
Command complete

Press 'q' to Logout.
Press 'h' for help.
Press eth0 for Ethernet configurations.
```

## 8. GTY

- This command is used to change **Gateway** DDU-TM-44/46 or DDU-44/46.
- Gateway should be entered in **xxx.xxx.xxx.xxx** form.
- Enter new Gateway and press enter. To save the new Gateway. Press '**Y**' else press '**N**'. If you press **Y** new Gateway will be saved and if you press **N** the previous Gateway will be retained

- Gateway of DDU-TM-44/46 or DDU-44/46 is 192.168.100.1 by default.

```
Ca: Telnet 192.168.100.32
*****
Masibus Telnet Server
*****

Login:masibus
Password:
Logged in successfully

Press 'q' to Logout.
Press 'h' for help.
Press eth0 for Ethernet configurations.

GTY
Enter Gateway:192.168.100.1

Command complete,
To save changes press 'Y' else press 'N':Y
Command complete

Press 'q' to Logout.
Press 'h' for help.
Press eth0 for Ethernet configurations.
```

#### 9. SIP1

- This command is used to change IP address of NTP time source (**NTP Primary Server**) for DDU-TM-44/46 or DDU-44/46 IP address should be entered in **xxx.xxx.xxx.xxx** form.
- Enter new IP address and press enter. To save the new IP address Press '**Y**' else press '**N**'. If you press **Y** new IP address will be saved and if you press **N** the previous IP address will be retained.
- IP address of NTP time source (NTP Primary server) for DDU-TM-44/46 or DDU-44/46 is 192.168.100.153 by default.

```
Ca: Telnet 192.168.100.32
*****
Masibus Telnet Server
*****

Login:masibus
Password:
Logged in successfully

Press 'q' to Logout.
Press 'h' for help.
Press eth0 for Ethernet configurations.

SIP1
Enter Primary NTP Server Address:192.168.100.153

Command complete,
To save changes press 'Y' else press 'N':Y
Command complete

Press 'q' to Logout.
Press 'h' for help.
Press eth0 for Ethernet configurations.
```

#### 10. SIP2

- This command is used to change IP address of NTP time source (**NTP Secondary Server**) for DDU-TM-44/46 or DDU-44/46.
- IP address should be entered in **xxx.xxx.xxx.xxx** form.
- Enter new IP address and press enter. To save the new IP address Press '**Y**' else press '**N**'. If you press **Y** new IP address will be saved and if you press **N** the previous IP address will be retained.

- IP address of NTP time source (NTP Secondary Server) for DDU-TM-44/46 or DDU-44/46 is 192.168.100.154 by default.

```
Telnet 192.168.100.32
*****
Masibus Telnet Server
*****
Login:masibus
Password:
Logged in successfully
Press 'q' to Logout.
Press 'h' for help.
Press eth0 for Ethernet configurations.
SIP2
Enter Secondary NTP Server Address:192.168.100.154
Command complete,
To save changes press 'Y' else press 'N':Y
Command complete
Press 'q' to Logout.
Press 'h' for help.
Press eth0 for Ethernet configurations.
```

#### 11. NQI

- This command is used to change **NTP Query Interval Time** [When Querying NTP Servers] for DDU-TM-44/46 or DDU-44/46.
- NTP Query Interval Time should be entered between 16 to 60.
- Enter new NTP Query Interval Time and Press Enter. To save the new NTP Query Interval Time Press 'Y' else press 'N'. If you press Y new NTP Query Interval Time will be saved and if you press N the previous NTP Query Interval Time will be retained.
- NTP Query Interval Time [When Querying NTP Servers] for DDU-TM-44/46 or DDU-44/46 is 16 by default.

```
Telnet 192.168.100.32
*****
Masibus Telnet Server
*****
Login:masibus
Password:
Logged in successfully
Press 'q' to Logout.
Press 'h' for help.
Press eth0 for Ethernet configurations.
NQI
Enter Query Interval Time [When Querying NTP Server][Between 16 To 60]:16
Query Interval Time Set Successfully
Command complete,
To save changes press 'Y' else press 'N':Y
Command complete
Press 'q' to Logout.
Press 'h' for help.
Press eth0 for Ethernet configurations.
```

#### 12. NQT

- This command is used to change **NTP Query Request Time Out Time** for DDU-TM-44/46 or DDU-44/46.
- NTP Query Request Time Out Time should be entered between 1 to 60.
- Enter new NTP Query Request Time Out Time and Press Enter. To save the new NTP Query Request Time Out Time Press 'Y' else press 'N'. If you press Y new NTP Query Request Time

Out Time will be saved and if you press **N** the previous NTP Query Request Time Out Time will be retained.

- NTP Query Request Time Out Time for DDU-TM-44/46 or DDU-44/46 is 2 by default.

```
Telnet 192.168.100.32
*****
Masibus Telnet Server
*****

Login:masibus

Password:
Logged in successfully

Press 'q' to Logout.
Press 'h' for help.
Press eth0 for Ethernet configurations.

NQT

Enter Query Request Time Out[Between 1 To 60]:2

Query Request Time Out Set Successfully
Command complete,
To save changes press 'Y' else press 'N':Y
Command complete

Press 'q' to Logout.
Press 'h' for help.
Press eth0 for Ethernet configurations.
```

### 13. NQR

- This command is used to change **NTP Query Retry Time** for DDU-TM-44/46 or DDU-44/46.
- NTP Query Retry Time should be entered between 1 to 60.
- Enter new NTP Query Retry Time and Press Enter. To save the new NTP Query Retry Time Press **'Y'** else press **'N'**. If you press **Y** new NTP Query Retry Time will be saved and if you press **N** the previous NTP Query Retry Time will be retained.
- NTP Query Retry Time for DDU-TM-44/46 or DDU-44/46 is 2 by default.

```
Telnet 192.168.100.32
*****
Masibus Telnet Server
*****

Login:masibus

Password:
Logged in successfully

Press 'q' to Logout.
Press 'h' for help.
Press eth0 for Ethernet configurations.

NQR

Enter Query Retry Time[Between 1 To 60]:2

Query Retry Interval Set Successfully
Command complete,
To save changes press 'Y' else press 'N':Y
Command complete

Press 'q' to Logout.
Press 'h' for help.
Press eth0 for Ethernet configurations.
```

### 14. NOT

- This command is used to change **NTP Number of time out counts** before switching servers for DDU-TM-44/46 or DDU-44/46.
- Number of time out counts before switching servers me should be entered between 1 to 15.
- Enter new Number of time out counts before switching servers and Press Enter. To save the new Number of time out counts before switching servers Press **'Y'** else press **'N'**. If you press **Y** new

Number of time out counts before switching servers will be saved and if you press **N** the previous Number of time out counts before switching servers will be retained.

- Number of time out counts before switching servers for DDU-TM-44/46 or DDU-44/46 is 3 by default.

```
Telnet 192.168.100.32
*****
Masibus Telnet Server
*****

Login:masibus
Password:
Logged in successfully

Press 'q' to Logout.
Press 'h' for help.
Press eth0 for Ethernet configurations.

NOT

Enter Number Of Time Out Counts Before Switching Servers[Between 1 To 15]:3

Number of Retry Count Set Successfully
Command complete,
To save changes press 'Y' else press 'N':Y
Command complete

Press 'q' to Logout.
Press 'h' for help.
Press eth0 for Ethernet configurations.
```

#### 15. SNS

- This command is used to enable or Disable **Secondary Server Option for NTP** for DDU-TM-44/46 or DDU-44/46.
- The Selection of Secondary NTP server enables or Disable by Pressing '**E**' or '**D**' followed by enter Key respectively.
- To save the Selection of Secondary Server Option Press '**Y**' else press '**N**'. If you press **Y** new Selection of Secondary Server option will be saved and if you press **N** the previous Selection of Secondary Server will be retained.
- By Default Secondary server Option for NTP is Disable.

```
Telnet 192.168.100.32
*****
Masibus Telnet Server
*****

Login:masibus
Password:
Logged in successfully

Press 'q' to Logout.
Press 'h' for help.
Press eth0 for Ethernet configurations.

SNS

Press E To Enable Secondary NTP Server else Press D:E

Secondary NTP server option Set Successfully
Command complete,
To save changes press 'Y' else press 'N':Y
Command complete

Press 'q' to Logout.
Press 'h' for help.
Press eth0 for Ethernet configurations.
```

#### 16. SNMP1

- This command is used to change IP address of SNMP Manager 1 for DDU-TM-44/46 or DDU-44/46 for SNMP 1/2 Protocol.

- IP address should be entered in **xxx.xxx.xxx.xxx** form.
- Enter new SNMP IP address and press enter. To save the new SNMP IP address Press **'Y'** else press **'N'**. If you press **Y** new SNMP IP address will be saved and if you press **N** the previous SNMP IP address will be retained.
- SNMP Manager IP1 for DDU-TM-44/46 or DDU-44/46 is 192.168.100.226 by default.

```
Telnet 192.168.100.32
Masibus Telnet Server
Login:masibus
Password:
Logged in successfully
Press 'q' to Logout.
Press 'h' for help.
Press eth0 for Ethernet configurations.
SNMP1
Enter SNMP Manager IP1:192.168.100.226
Command complete,
To save changes press 'Y' else press 'N':Y
Command complete
Press 'q' to Logout.
Press 'h' for help.
Press eth0 for Ethernet configurations.
```

#### 17. SNMP2

- This command is used to change IP address of SNMP Manager 2 for DDU-TM-44/46 or DDU-44/46 for SNMP 1/2 protocol.
- IP address should be entered in **xxx.xxx.xxx.xxx** form.
- Enter new SNMP IP address and press enter. To save the new SNMP IP address Press **'Y'** else press **'N'**. If you press **Y** new SNMP IP address will be saved and if you press **N** the previous SNMP IP address will be retained.
- SNMP Manager IP2 for DDU-TM-44/46 or DDU-44/46.
- is 192.168.100.226 by default.

```
Telnet 192.168.100.32
Masibus Telnet Server
Login:masibus
Password:
Logged in successfully
Press 'q' to Logout.
Press 'h' for help.
Press eth0 for Ethernet configurations.
SNMP2
Enter SNMP Manager IP2:192.168.100.226
Command complete,
To save changes press 'Y' else press 'N':Y
Command complete
Press 'q' to Logout.
Press 'h' for help.
Press eth0 for Ethernet configurations.
```

#### 18. SWC

- This command is used to change Write Community of Both SNMP Manager for DDU-TM-44/46 or DDU-44/46 SNMPv1 / SNMPv2c protocol.
- This string Length should be less than 21 character.
- Enter new Write Community and press enter. To save the new Write Community Press **'Y'** else press **'N'**. If you press **Y** new Write Community will be saved and if you press **N** the previous Write Community will be retained.

- SNMP Write community for DDU-TM-44/46 or DDU-44/46 is masibus by default.

```
C:\> Telnet 192.168.100.32
Masibus Telnet Server

Login:masibus
Password:
Logged in successfully
Press 'q' to Logout.
Press 'h' for help.
Press eth0 for Ethernet configurations.
SWC
Enter New SNMP Write Community:masibus
SNMP Write Community Set
Command complete,
To save changes press 'Y' else press 'N':Y
Command complete
Press 'q' to Logout.
Press 'h' for help.
Press eth0 for Ethernet configurations.
```

19. SRC

- This command is used to change Read Community of Both SNMP Manager for DDU-TM-44/46 or DDU-44/46 SNMPv1 / SNMPv2c protocol.
- This string Length should be less than 21 character.
- Enter new Read Community and press enter. To save the new Read Community Press 'Y' else press 'N'. If you press Y new Read Community will be saved and if you press N the previous Read Community will be retained.
- SNMP Read community for DDU-TM-44/46 or DDU-44/46 is masibus by default.

```
C:\> Telnet 192.168.100.32
Masibus Telnet Server

Login:masibus
Password:
Logged in successfully
Press 'q' to Logout.
Press 'h' for help.
Press eth0 for Ethernet configurations.
SRC
Enter New SNMP Read Community:masibus
SNMP Read Community Set
Command complete,
To save changes press 'Y' else press 'N':Y
Command complete
Press 'q' to Logout.
Press 'h' for help.
Press eth0 for Ethernet configurations.
```

20. SD

- This command is used for Ethernet Parameter Default configuration
- By entering "SD" You can set Default configuration of Ethernet Parameter.



## 21. Z

- This command is used to Set **Time Zone Offset Configuration** for DDU-TM-44/46 or DDU-44/46.
- By entering “Z” You will enter in Time Zone Offset Configuration.

```
ca Telnet 192.168.100.32
*****
Masibus Telnet Server
*****

Login:masibus

Password:
Logged in successfully

Press 'q' to Logout.
Press 'h' for help.
Press eth0 for Ethernet configurations.

Z
Time Zone Offset Configuration
Command : Function
  1 : View Time Zone Configuration Parameters
  2 : Enter Time Zone Offset
  3 : Time Zone Offset for NTP
  4 : Enable Time Zone Offset For SERIAL
```

### 16.1 “Z” ”1” Command:

- By Press “1” enter in “Z” menu for View Time Zone Configuration, you will get Details of Current Time Zone Settings.

```
ca Telnet 192.168.100.32
*****
Masibus Telnet Server
*****

Login:masibus

Password:
Logged in successfully

Press 'q' to Logout.
Press 'h' for help.
Press eth0 for Ethernet configurations.

Z
Time Zone Offset Configuration
Command : Function
  1 : View Time Zone Configuration Parameters
  2 : Enter Time Zone Offset
  3 : Time Zone Offset for NTP
  4 : Enable Time Zone Offset For SERIAL
1
Time Zone Offset :+05:30
Time Zone Offset For NTP :Enable
Time Zone Offset For SERIAL :Enable
```

### 16.2 “Z” ”2” Command:

- By Press “2” enter in “Z” menu for to Set Time Zone offset.
- Enter Standard Time Zone in +HH:MM or –HH:MM format, any else than Standard time zone will give invalid entry message.
- To save the Selection of Time Zone offset Press ‘Y’ else press ‘N’. If you press Y new Selection of Time Zone offset will be saved and if you press N the previous Selection of Time Zone offset will be retained.
- By Default Time Zone Offset is +05:30.

```
Telnet 192.168.100.32
*****
Masibus Telnet Server
*****

Login:masibus
Password:
Logged in successfully

Press 'q' to Logout.
Press 'h' for help.
Press eth0 for Ethernet configurations.

Z
Time Zone Offset Configuration
Command : Function
  1      : View Time Zone Configuration Parameters
  2      : Enter Time Zone Offset
  3      : Time Zone Offset for NTP
  4      : Enable Time Zone Offset For SERIAL
2
Time Zone Offset Configuration
Enter Time Zone Offset[+HH:MM or -HH:MM]:+05:30

Time zone offset set successfully
Command complete,
To save changes press 'Y' else press 'N':Y
Command complete

Press 'q' to Logout.
Press 'h' for help.
Press eth0 for Ethernet configurations.
```

### 16.3 “Z” ”3” Command:

- By Press “3” enter in “Z” menu for to enable Time Zone offset for NTP input.
- Enter “0” followed by Enter, it will disable Time zone offset for NTP.
- Enter “1” followed by Enter, it will enable Time zone offset for NTP.
- To save the Selection of Time Zone offset for NTP input Press ‘Y’ else press ‘N’. If you press Y new Selection of Time Zone offset for NTP input will be saved and if you press N the previous Selection of Time Zone offset for NTP input will be retained.
- By default it is Disable for NTP.

```
Telnet 192.168.100.32
*****
Masibus Telnet Server
*****

Login:masibus
Password:
Logged in successfully

Press 'q' to Logout.
Press 'h' for help.
Press eth0 for Ethernet configurations.

Z
Time Zone Offset Configuration
Command : Function
  1      : View Time Zone Configuration Parameters
  2      : Enter Time Zone Offset
  3      : Time Zone Offset for NTP
  4      : Enable Time Zone Offset For SERIAL
3
Time Zone Offset Configuration
Time Zone Offset For NTP
Command : Function
  0      : Time Zone Offset Disable
  1      : Time Zone Offset Enable
1
NTP Time zone offset set successfully
Command complete,
To save changes press 'Y' else press 'N':Y
Command complete

Press 'q' to Logout.
Press 'h' for help.
Press eth0 for Ethernet configurations.
```

#### 16.4 “Z” “4” Command:

- By Press “3” enter in “Z” menu for to enable Time Zone offset for SERIAL input.
- Enter “0” followed by Enter, it will disable Time zone offset for SERIAL.
- Enter “1” followed by Enter, it will enable Time zone offset for SERIAL.
- To save the Selection of Time Zone offset for SERIAL input Press ‘Y’ else press ‘N’. If you press Y new Selection of Time Zone offset for SERIAL input will be saved and if you press N the previous Selection of Time Zone offset for SERIAL input will be retained.
- By default it is disable for SERIAL.

```
ca Telnet 192.168.100.32
*****
Masibus Telnet Server
*****

Login:masibus
Password:
Logged in successfully

Press 'q' to Logout.
Press 'h' for help.
Press eth0 for Ethernet configurations.

Z
Time Zone Offset Configuration
Command : Function
  1 : View Time Zone Configuration Parameters
  2 : Enter Time Zone Offset
  3 : Time Zone Offset for NTP
  4 : Enable Time Zone Offset For SERIAL
4
Time Zone Offset Configuration
Time Zone Offset For SERIAL
Command : Function
  0 : Time Zone Offset Disable
  1 : Time Zone Offset Enable
1

SERIAL Time zone offset set successfully
Command complete,
To save changes press 'Y' else press 'N':Y
Command complete

Press 'q' to Logout.
Press 'h' for help.
Press eth0 for Ethernet configurations.
```

#### 22. MT

- This command is used to Set **Manual Time Setting** for DDU-TM-44/46 or DDU-44/46.
- By entering “MT” You will enter in **Manual Time Setting** Configuration.
- Enter Time and Date in HH:MM,DD/MM/YY mode for DDU-TM-44/46 or DDU-44/46 after it will give conformation.

```
ca Telnet 192.168.100.32
*****
Masibus Telnet Server
*****

Login:masibus
Password:
Logged in successfully

Press 'q' to Logout.
Press 'h' for help.
Press eth0 for Ethernet configurations.

MT
Manual Time And Date Setting
Enter Time and Date [HH:MM,DD/MM/YY]:10:30,06/04/19

Manual Time and Date set successfully
Command complete,
To save changes press 'Y' else press 'N':Y
Command complete

Press 'q' to Logout.
Press 'h' for help.
Press eth0 for Ethernet configurations.
```

23. P

- The user is allowed to change telnet password. The command for changing the password is: P (**password**).
- Then enter new password and press enter. To save the new password press 'Y' else press 'N'. If you press Y new password will be saved and if you press N the previous password will be retained.
- The default password is 'masibus'.
- Remember that the password should not exceed 10 characters. If you try to keep a password that has more than 10 characters, the system will show an error "Invalid Entry" and the previous password will be retained.

```

C:\> Telnet 192.168.100.32
*****
Masibus Telnet Server
*****

Login:masibus

Password:
Logged in successfully

Press 'q' to Logout.
Press 'h' for help.
Press eth0 for Ethernet configurations.

P

Enter new Telnet Password:
Password changed.
Command complete,
To save changes press 'Y' else press 'N':Y
Command complete

Press 'q' to Logout.
Press 'h' for help.
Press eth0 for Ethernet configurations.

```

24. U

- The user is allowed to change telnet Login name. The command for changing the Login name is: 'U'.
- Then enter new Login name and press enter. To save the new Login name. Press 'Y' else press 'N'. If you press Y new Login name will be saved and if you press N the previous Login name will be retained.
- The default Login name is 'masibus'.
- Remember that the Login name should not exceed 10 characters. If you try to keep a Login name that has more than 10 characters, the system will show an error "Invalid Entry" and the previous Login name will be retained.

```

C:\> Telnet 192.168.100.32
*****
Masibus Telnet Server
*****

Login:masibus

Password:
Logged in successfully

Press 'q' to Logout.
Press 'h' for help.
Press eth0 for Ethernet configurations.

U

Enter new Telnet Username:
Username changed.
Command complete,
To save changes press 'Y' else press 'N':Y
Command complete

Press 'q' to Logout.
Press 'h' for help.
Press eth0 for Ethernet configurations.

```

25. H

This **HELP** command is used to see different commands and their functions.

```

C:\ Telnet 192.168.100.32
H
-----
COMMAND  FUNCTION
-----
IP        IP address
MASK      SUBNET MASK
GTY       GATEWAY
SIP1      Primary NTP Server Address
SIP2      Secondary NTP Server Address
NQI       Query Interval Time[When Querying NTP Servers]
NQT       Query Request Time Out
NQR       Query Retry Interval
NOT       Number Of Time Outs Before switching Servers
SNS       Secondary Server option for NTP
Z         Time Zone Offset Configuration
MT        Manual Time And Date Setting
SNMP1     SNMP Manager IP1
SNMP2     SNMP Manager IP2
SWC       SNMP Write Community
SRC       SNMP Read Community
SD        Ethernet Default configuration set
P         Password
U         User name
  
```

26. ETH0 [ETH(Zero)]

This command is used to see present NTP configurations.

```

C:\ Telnet 192.168.100.32
ETH0
IP Address           :192.168.100.032
Subnet Mask          :255.255.255.000
Gateway              :192.168.100.001
Primary NTP Server Address :192.168.100.153
Secondary NTP Server Address :192.168.100.154
NTP Query Interval Time :0016
NTP Query Time Out    :002
NTP Query Retry Interval :002
Number Of Retry Before Switching NTP Server:003
Secondary Server option for NTP :Disable
SNMP Manager IP1     :192.168.100.226
SNMP Manager IP2     :192.168.100.226
SNMP Write Community :masibus
SNMP Read Community  :masibus
  
```

27. Q

This command is used to close Telnet session.

#### 6.2.4.3 Important Points for Telnet Configuration

- Digital Display Unit's Telnet Server has timeout period of 5 minutes. If you do not press any character till 5 minutes, the session will be automatically closed with a message of Timeout, Session Closed.
- Commands are case insensitive.
- If Display Unit Telnet server is open at that time Display Unit will not synchronize with the NTP Time Source.

- Display Unit operates in NTP client mode.

### 6.2.5 Serial Configuration [with NTP or PoE Option]

DDU-TM-44/46 or DDU-44/46 offers facility to the users for configuring communication parameters of serial port, Display Format Selection, Time Zone Selection, Ethernet Configuration, Manual Time Set, Set Default Parameter and View Current Settings.

- The communication parameters include baud rate, number of stop bits and parity
- In Ethernet Configuration, User can set, IP, MASK, GATEWAY, SUBNET, Primary Server IP, Secondary Server IP, NTP Query Interval Time [When Querying NTP Server] , Query Request Timeout , Query Retry Interval , Number of Time outs Before switching Servers, Secondary Server Option For NTP, SNMP Manger IP addresses and its write and Read community.
- User Can Set Manual Time if no availability of Time Inputs
- The user is free to choose Time Display, Date Display and Both in Alternate Time/Date Display.
- User can set any Standard Time Zone Offset, in any Input like NTP and Serial
- The user can enter the time offset of the time zone, where the unit is to be installed
- Users can set Default all Configuration Parameter and View Current Configuration Parameter using Serial Configuration
- User Can Check Current Synchronization [with NTP server] Status of DDU Configuration Parameter

**Note:** - Serial configuration option provide in NTP or PoE with serial model option only. This Feature not available in Wireless with serial model option.

#### 6.2.5.1 For The First Time Setup Follow the Below Procedure

- Configuration requires a RS232 cable as per Figure 18 or standard 2-way twisted pair RS-485 Cable with standard RS485 to RS232 Converter and standard communication software in the PC, such as HyperTerminal. HyperTerminal is available in every Windows based PC on the Path Program -> Accessories -> Communication ->HyperTerminal.
- Open the HyperTerminal and start new connection on COMx of your PC. (x can be any available serial RS232 port number)
- In using HyperTerminal, it is recommended to select File\Properties\Settings and set Emulation to ANSI, to avoid auto-detect making unwanted changes to the settings.
- The port settings in HyperTerminal and the COM port of the DDU-24/26 must match each other for fruitful communication. The default settings of COM port of the DDU-24/26 are 9600 baud, 8, N, 1. The settings of the HyperTerminal must be set same as COM port of the DDU-24/26 to initialize the communication. Please Follow Below steps on the HyperTerminal.
  - Step 1: Open Hyper Terminal
  - Step 2: Hyper Terminal Name
  - Step 3: Select Local PC COM Port, in which you wish to connect DDU-TM-44/46 or DDU-44/46.
  - Step 4: Select Baud Rate, Parity Bit and Stop Bit.

**Note:** - RS485 to RS232 converter is not supplied along with the product,  
In place of RS485 to RS232 converter, RS485 to USB converter also can be used.

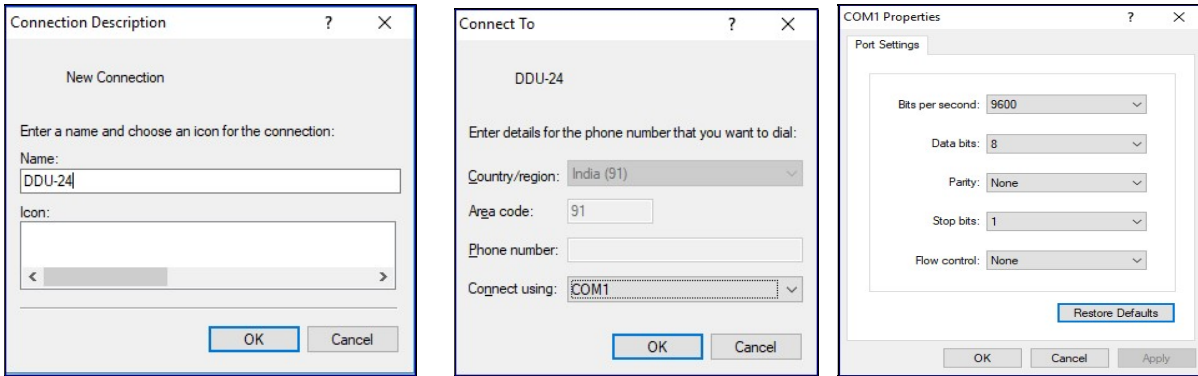

### 6.2.5.2 CONFIGURATION COMMANDS AND PASSWORD

#### 1) "CONFIG" command and Password:

- Enter "CONFIG" followed by Enter.
- You will get Password Page as shown in below image

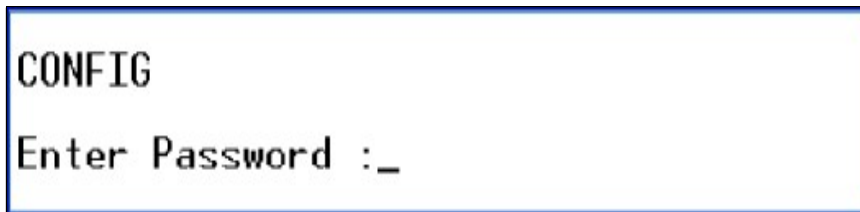

- Password is user defined and by default password is "masibus". User can change this password by logging in by entering correct password. Enter Correct Password "masibus", if password is matched it will give conformation of password OK and ask to enter command to Configure parameter as shown in below image

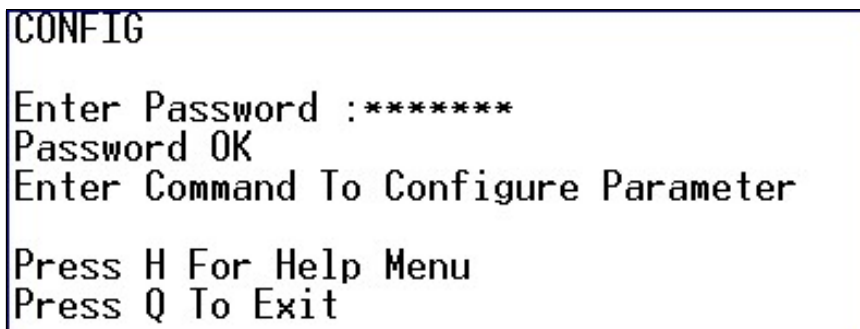

- If you enter a wrong password it will give message of access denied and ask to enter "CONFIG"

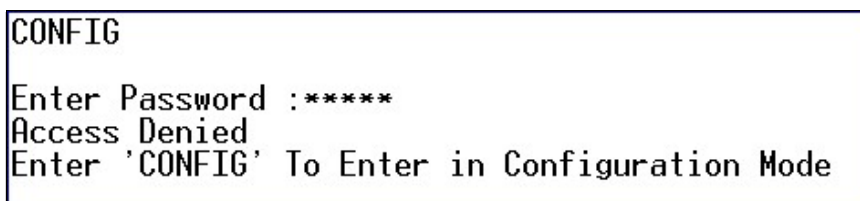

**2) "H" and "Q" command:**

- By Entering Correct password user can enter in configuration mode in this page it will ask to press "H" For Help Menu and "Q" for Exit.
- Press "H" followed by Enter you will see below image.

```
H
*****
                DDU-XX|
*****
Commands :    Function
S           :    Serial Configuration
E           :    Ethernet Configuration
M           :    Manual Time & Date Setting
D           :    Display Configuration
UNLO       :    Unlock Blinking Set Configuration
Z           :    Time Zone Offset Configuration
PWD        :    Change Password
SD         :    Set Default All Parameters
L          :    List Of Current Parameters
CS         :    Current Sync Status

Enter Commands To Configure Parameters
Press Q To Exit
```

- Press "Q" followed by Enter you will see below image.

```
Q
You Have Exit From Configuration Mode
```

**3) "S" command:**

- Press "S" for Serial Configuration:
- By entering "S" followed by Enter you will see below image.

```
S

Serial Configuration
Command   :    Function
  1       :    Baud Rate
  2       :    Stop Bit
  3       :    Parity

Press H For Help Menu
Press Q To Exit
```

**3.1) "S" "1" command:**

- If you want to change Baud Rate of Serial Port , Enter "1" followed by Enter , then it will show below image
- Press Command between 1 to 2, according below image to set your baud rate.
- If you want to set 19200 baud rate then press 2, by pressing 2 followed by Enter, it will set baud rate of 19200 and Communication must stopped.
- If your Device baud rate and hyper terminal Baud rate is not same, then hyper terminal stop the working you have to again configure the Hyper terminal baud rate.
- You have to disconnect the hyper terminal and then from File->Properties, change Baud rate accordingly.



```
1

Serial Configuration
Baud Rate Selection
Command   :   Baud Rate
   1     :   9600
   2     :   19200

Press H For Help Menu
Press Q To Exit
```

**3.2) “S” “2” command:**

- If you want to change Stop Bit of Serial Port , Enter “2” followed by Enter in “S” menu, then it Will show below image

```
2

Serial Configuration
Stop Bit Selection
Command   :   Function
   1     :   1 Stop Bit
   2     :   2 Stop Bit

Press H For Help Menu
Press Q To Exit
```

- Press Command 1 for 1 Stop bit and Press 2 for 2 stop bit.
- If you want to set 1 Stop Bit then press 1, followed by Enter, it will set stop bit 1.
- You have to disconnect the hyper terminal and then from File->Properties, change Stop bit accordingly.

**3.3) “S” “3” command:**

- If you want to change Parity Bit of Serial Port , Enter “3” followed by Enter in “S” menu, then it Will show below image

```
3

Serial Configuration
Parity Selection
Command   :   Function
   1     :   Even Parity
   2     :   Odd Parity
   3     :   None Parity

Press H For Help Menu
Press Q To Exit
```

- Press Command between 1 to 3, according to what you have to set the Parity Bit.
- If you want to set Even Parity Bit then press 1, followed by Enter, it will set Parity Bit to Even And Communication must stopped.

- You have to disconnect the hyper terminal and then from File->Properties, change Parity Bit according to your set value.

**4) “E” command:**

- Press “E” for Ethernet Configuration:
- By entering “E” followed by Enter you will see below image

```
Ethernet Configuration
Command : Function
 1      : View Current Ethernet Parameters
 2      : Set IP Address
 3      : Set Subnet Mask
 4      : Set Gateway
 5      : Set Primary Server IP Address
 6      : Set Secondary Server IP Address
 7      : Query Interval Time [When Querying NTP Server]
 8      : Query Request Time out
 9      : Query Retry Interval
10     : Number of Time outs Before switching Servers
11     : Secondary Server option for NTP
12     : Set SNMP Manager IP1
13     : Set SNMP Manager IP2
14     : Set SNMP Write Community
15     : Set SNMP Read Community
16     : Set Default Ethernet Parameters

Press H For Help Menu
Press Q To Exit
```

**.1) “E” “1” command:**

- If you want to view current Ethernet Parameter, Enter “1” followed by Enter in “E” menu, then it will show below image

```
1

List Of Ethernet Parameters

IP Address           :192.168.100.032
Subnetmask           :255.255.255.000
Gateway              :192.168.100.001
Primary Server IP Address :192.168.100.153
Secondary Server IP Address :192.168.100.154
Query Interval Time[When Querying NTP Server] :0016
Query Request Time out :02
Query Retry Interval :02
Number of Time outs Before switching Servers :03
Secondary Server option for NTP :Disable
SNMP Manager IP1     :192.168.100.226
SNMP Manager IP2     :192.168.100.226
SNMP Write Community :masibus
SNMP Read Community  :masibus

Press H For Help Menu
Press Q To Exit
```

**.2) “E” “2” command:**

- If you want to set IP Address of DDU-TM-44/46 or DDU-44/46 device, Enter “2” followed by Enter in “E” menu, then it Will show below image and Ask for to Enter IP Address in XXX.XXX.XXX.XXX format.
- After Entering IP Address, it will give conformation as shown in below image and if you enter wrong address it will give message of invalid data.
- By Default IP Address is 192.168.100.32

```
2
Ethernet Configuration
Press H For Help Menu
Press Q To Exit

Enter IP Address[XXX.XXX.XXX.XXX]:192.168.100.32

IP Address Stored Successfully

Press H For Help Menu
Press Q To Exit
```

**.3) “E” “3” command:**

- If you want to set IP Address of Subnet MASK of DDU-TM-44/46 or DDU-44/46 device, Enter “3” followed by Enter in “E” menu, then it will show below image and Ask for to Enter IP Address of Subnet MASK in XXX.XXX.XXX.XXX format.
- After Entering IP Address of Subnet MASK, it will give conformation as shown in below image and if you enter wrong address it will give message of invalid data.
- By Default IP Address of Subnet MASK is 255.255.255.0

```
3
Ethernet Configuration
Press H For Help Menu
Press Q To Exit

Enter Subnet Mask[XXX.XXX.XXX.XXX]:255.255.255.0

Subnet Mask Stored Successfully

Press H For Help Menu
Press Q To Exit
```

**.4) “E” “4” command:**

- If you want to set IP Address of Gateway of DDU-TM-44/46 or DDU-44/46 device, Enter “4” followed by Enter in “E” menu, then it will show below image and Ask for to Enter IP Address of Gateway in XXX.XXX.XXX.XXX format.
- After Entering IP Address of Gateway, it will give conformation and if you enter wrong address it will give message of invalid data.
- By Default IP Address of Gateway is 192.168.100.1

```
4
Ethernet Configuration
Press H For Help Menu
Press Q To Exit

Enter Gateway [XXX.XXX.XXX.XXX]:192.168.100.1

Gateway Stored Successfully

Press H For Help Menu
Press Q To Exit
```

**.5) "E" "5" command:**

- If you want to set IP Address of Primary Server of DDU-TM-44/46 or DDU-44/46 device, Enter "5" followed by Enter in "E" menu, then it will show below image and Ask for to Enter IP Address of Primary Server in XXX.XXX.XXX.XXX format
- After Entering IP Address of Primary Server, it will give conformation as shown in below image and if you enter wrong address it will give message of invalid data
- By Default IP Address of Primary Server is 192.168.100.153

```
5
Ethernet Configuration
Press H For Help Menu
Press Q To Exit

Enter Primary Server IP Address[XXX.XXX.XXX.XXX]:192.168.100.153

Primary Server IP Address Stored Successfully

Press H For Help Menu
Press Q To Exit
```

**.6) "E" "6" command:**

- If you want to set IP Address of Secondary Server of NTP in DDU-TM-44/46 or DDU-44/46 device, Enter "6" followed by Enter in "E" menu, then it will show below image and Ask for to Enter IP Address of Secondary Server in XXX.XXX.XXX.XXX format.
- After Entering IP Address of Secondary Server, it will give conformation as shown in below image and if you enter wrong address it will give message of invalid data.
- By Default IP Address of Secondary Server is 192.168.100.154

```
6
Ethernet Configuration
Press H For Help Menu
Press Q To Exit

Enter Secondary Server IP Address [XXX.XXX.XXX.XXX]:192.168.100.154

Secondary Server IP Address Stored Successfully

Press H For Help Menu
Press Q To Exit
```

**.7) "E" "7" command:**

- If you want to set Query Interval Time [When Querying NTP Server] of DDU-TM-44/46 or DDU-44/46 device, Enter "7" followed by Enter in "E" menu, then it will show below image and Ask for to Query Interval Time between 16 to 60.
- After Entering Query Interval Time, it will give conformation as shown in below image and if you enter wrong value it will give message of invalid data.
- By Default Query Interval Time is 16.

```
7
Ethernet Configuration
Press H For Help Menu
Press Q To Exit

Enter Query Interval Time [When Querying NTP Server][Between 16 To 0060]:16

Query Interval Time Set Successfully

Press H For Help Menu
Press Q To Exit
```

**.8) "E" "8" command:**

- If you want to set Query Request Time Out in DDU-TM-44/46 or DDU-44/46 device, Enter "8" followed by Enter in "E" menu, then it will show below image and Ask for to Enter set Query Request Time Out between 1 to 60.
- After Entering set Query Request Time Out, it will give conformation as shown in below image and if you enter wrong address it will give message of invalid data.
- By Default set Query Request Time Out is 2

```
8
Ethernet Configuration
Press H For Help Menu
Press Q To Exit

Enter Query Request Time Out[Between 1 To 60]:2

Query Request Time Out Set Successfully

Press H For Help Menu
Press Q To Exit
```

**.9) "E" "9" command:**

- If you want to set Query Retry Time in DDU-TM-44/46 or DDU-44/46 device, Enter "9" followed by Enter in "E" menu, then it will show below image and Ask for to Enter set Query Retry Time between 1 to 60.
- After Entering set Query Retry Time, it will give conformation as shown in below image and if you enter wrong address it will give message of invalid data.
- By Default Query Retry Time is 2

```
9
Ethernet Configuration
Press H For Help Menu
Press Q To Exit

Enter Query Retry Time[Between 1 To 60]:2

Query Retry Time Set Successfully

Press H For Help Menu
Press Q To Exit
```

**.10) "E" "10" command:**

- If you want to set Number of time out counts before switching servers in DDU-TM-44/46 or DDU-44/46 device, Enter "10" followed by Enter in "E" menu, then it will show below image and Ask for to Enter to set Number of time out counts between 1 to 60.
- After Entering set Number of time out counts, it will give conformation as shown in below image and if you enter wrong address it will give message of invalid data.
- By Default Number of time out counts is 3

```
10
Ethernet Configuration
Press H For Help Menu
Press Q To Exit

Enter Number Of Time Out Counts Before Switching Servers[Between 1 To 15]:3
Number of Time Out Counts Set Successfully

Press H For Help Menu
Press Q To Exit
```

**.11) “E” “11” command:**

- If you want Enable or Disable Secondary Server Option for NTP before switching servers in DDU-TM-44/46 or DDU-44/46 device, Enter “11” followed by Enter in “E” menu, then it will show in below image and Ask for to Enable or Disable Secondary Server Option for NTP.
- After Enable or Disable Secondary Server Option for NTP, it will give conformation as shown in below image and if you enter wrong value it will give message of invalid data.
- By Secondary Server Option for NTP is Disable

```
11

Ethernet Configuration

Press H For Help Menu
Press Q To Exit

Secondary Server option for NTP

Command : Function
  0      : Disable
  1      : Enable

Press H For Help Menu
Press Q To Exit
```

```
1

Secondary NTP Server Enabled

Press H For Help Menu
Press Q To Exit
```

**.12) “E” “12” command:**

- If you want to set SNMP Manger IP1 Address of DDU-TM-44/46 or DDU-44/46 device, Enter “12” followed by Enter in “E” menu, then it will show below image and Ask for to Enter IP Address in XXX.XXX.XXX.XXX format.
- After Entering SNMP IP1 Address, it will give conformation as shown in below image and if you enter wrong address it will give message of invalid data.
- By Default SNMP manger IP1 Address is 192.168.100.226

```
12
Ethernet Configuration
Press H For Help Menu
Press Q To Exit

Enter SNMP Manager IP1[XXX.XXX.XXX.XXX]:192.168.100.226

SNMP Manager IP Address Stored Successfully

Press H For Help Menu
Press Q To Exit
```

**13 “E” “13” command:**

- If you want to set SNMP Manger IP2 Address of DDU-TM-44/46 or DDU-44/46 device, Enter “13” followed by Enter in “E” menu, then it will show below image and Ask for to Enter IP Address in XXX.XXX.XXX.XXX format.
- After Entering SNMP IP2 Address, it will give conformation as shown in below image and if you enter wrong address it will give message of invalid data.
- By Default SNMP manger IP2 Address is 192.168.100.226

```
13
Ethernet Configuration
Press H For Help Menu
Press Q To Exit

Enter SNMP Manager IP2[XXX.XXX.XXX.XXX]:192.168.100.226

SNMP Manager IP Address Stored Successfully

Press H For Help Menu
Press Q To Exit
```

**14 “E” “14” command:**

- If you want to set SNMP Write Community in DDU-TM-44/46 or DDU-44/46 device, Enter “14” followed by Enter in “E” menu, then it will show below image and Ask for to Enter SNMP Write Community of String format.
- This string Length should be less than 21 character.
- Enter new Write Community and press enter. After shown the message community set or not.
- SNMP Read community for DDU-TM-44/46 or DDU-44/46 is masibus by default.

```
14
Ethernet Configuration
Press H For Help Menu
Press Q To Exit

Enter New SNMP Write Community :masibus

SNMP Community set Successfully

Press H For Help Menu
Press Q To Exit
```

**15 “E” “15” command:**

- If you want to set SNMP Read Community in DDU-TM-44/46 or DDU-44/46 device, Enter “15” followed by Enter in “E” menu, then it will show below image and Ask for to Enter SNMP Read Community of String format.
- This string Length should be less than 21 character.

- Enter new Read Community and press enter. After shown the message community set or not.
- SNMP Read community for DDU-TM-44/46 or DDU-44/46 is masibus by default.

```
Ethernet Configuration
Press H For Help Menu
Press Q To Exit

Enter New SNMP Read Community :masibus
SNMP Community set Successfully

Press H For Help Menu
Press Q To Exit
```

**16 “E” “16” command:**

- If you want to set Default all Ethernet Parameter, Press “16” followed by enter in “E” menu, it will set default all parameter.

**5) “M” commands:**

- Press “M” for Manual Time Setting:
- By entering “M” followed by Enter you will get below image
- Enter Time and Date in HH:MM, DD/MM/YY mode after it will give conformation as shown in below image.

```
M
Manual Time And Date Setting
Press H For Help Menu
Press Q To Exit

Enter Time and Date [HH:MM,DD/MM/YY] :10:30,06/06/19
Manual Time And Date Set Successfully

Press H For Help Menu
Press Q To Exit
```

**6) “D” command:**

- Press “D” for Display Configuration:
- By entering “D” followed by Enter you will get below image

```
D
Display Configuration
Command  : Function
  1      : Time/Date Display selection
  2      : Date Format
  3      : Time Format

Press H For Help Menu
Press Q To Exit
```

**6.1) “D” “1” command:**

- Press “1” followed by enter in “D” menu for Time /Date Display selection :
- By entering “1” followed by Enter you will get below image



```
1
Display Configuration
Time/Date Display Selection
Command : Function
  1 : Enable Time Display
  2 : Enable Date Display
  3 : Enable Alternate Date/Time Display

Press H For Help Menu
Press Q To Exit
```

- If you want Enable Time Display, Press 1 it will set Time Display.
- If you want to Enable Date Display press 2, it will set Date Display.
- If you want both Date/Time Alternate Display Press 3, it will set in alternate display mode.

**6.2) “D” “2” command:**

- Press “2” followed by enter in “D” menu for **Date Format selection** you will get below figure
- In DDU-44 unit it display DD/MM and MM/DD option
- In DDU-46 unit it will display DD/MM/YY, MM/DD/YY or YY/MM/DD.

```
2
Display Configuration
Date Format
Command : Function
  1 : DD/MM/YY
  2 : MM/DD/YY
  3 : YY/MM/DD

Press H For Help Menu
Press Q To Exit
```

- Enter “1” followed by Enter, it will set DD/MM/YY Date Format.
- Enter “2” followed by Enter, it will set MM/DD/YY Date Format.
- Enter “3” followed by Enter, it will set YY/MM/DD Date Format.
- By Default Set format is DD/MM/YY for DDU-26 and DD/MM for DDU-24

**6.3) “D” “3” command:**

- Press “3” followed by enter in “D” menu for Time Format selection you will get below figure

```
3
Display Configuration
Time Format
Command : Function
  0 : 12 Hour Time Format
  1 : 24 Hour Time Format

Press H For Help Menu
Press Q To Exit
```

- Enter “0” followed by Enter, it will set 12 Hour Time Format.
- Enter “1” followed by Enter, it will set 24 Hour Time Format.
- By default Set Type is 24 Hour Time Format.

**7) "UNLO" command:**

- Press "UNLO" for Display Blink in unlock condition
- By entering "UNLO" followed by Enter you will get below image

```
UNLO

Display Configuration
Display Blink in Unlock Condition
Command : Function
  0      : Disable
  1      : Enable

Press H For Help Menu
Press Q To Exit
```

- Enter "0" followed by Enter, it will disable Display Blink Option[colon Led in steady Mode]
- Enter "1" followed by Enter, it will enable Display Blink Option[colon Led in Blink Mode]
- By default Display Blink option is enable

**8) "Z" command:**

- Press "Z" for Time Zone Offset Configuration:
- By entering "Z" followed by Enter you will get below image

```
Z

Time Zone Offset Configuration
Command : Function
  1      : View Time Zone Configuration Parameters
  2      : Enter Time Zone Offset
  3      : Enter Time Zone Offset For NTP
  4      : Enter Time Zone Offset For SERIAL

Press H For Help Menu
Press Q To Exit
```

**8.1) "Z" "1" command:**

- Press "1" followed by enter in "Z" menu for View Time Zone Configuration ,you will get Details of Current Time Zone Settings as shown in below image.

```
Time Zone Offset:+05:30
NTP Offset       :Enable
SERIEL Offset    :Enable

Press H For Help Menu
Press Q To Exit
```

**8.2) "Z" "2" command:**

- Press "2" followed by enter in "Z" menu for to Set Time Zone offset ,you will get below figure

```
2
Time Zone Offset Configuration
Press H For Help Menu
Press Q To Exit

Enter Time Zone Offset[+HH:MM or -HH:MM]:+05:30

Time zone offset set successfully

Press H For Help Menu
Press Q To Exit
```

- Enter Standard Time Zone in +HH:MM or -HH:MM format, any else than Standard time zone will give invalid entry message.
- By Default Time Zone Offset is +05:30.

### 8.3) "Z" "3" command:

- Press "3" followed by enter in "Z" menu for to enable Time Zone offset for NTP input, you will get below image
- Enter "0" followed by Enter in menu, it will disable Time zone offset for NTP.
- Enter "1" followed by Enter in menu, it will enable Time zone offset for NTP.
- By default it is disable for NTP.

```
3
Time Zone Offset Configuration

Time Zone Offset For NTP
Command      :  Function
      0      :  Time Zone Offset Disable
      1      :  Time Zone Offset Enable

Press H For Help Menu
Press Q To Exit
```

### 8.4) "Z" "4" command:

- Press "4" followed by enter in "Z" menu for to enable Time Zone offset for SERIAL input, you will get below image
- Enter "0" followed by Enter in menu, it will disable Time zone offset for SERIAL.
- Enter "1" followed by Enter in menu, it will enable Time zone offset for SERIAL.
- By default it is disable for SERIAL.

```
4
Time Zone Offset Configuration
Time Zone Offset For SERIAL
Command      : Function
  0          : Time Zone Offset Disable
  1          : Time Zone Offset Enable
Press H For Help Menu
Press Q To Exit
```

**9) "PWD" command:**

- Press "PWD" for User Password Change:
- By entering "PWD" followed by Enter you will get below image

```
PWD
Press 'ESC' To Exit From Password Change Mode
Enter New Password(Max 10 Characters,Case Sensitive):*****
Password Changed
Press H For Help Menu
Press Q To Exit
```

- Enter Password of maximum 10 character, more than 10 characters will give invalid entry.
- Password is case sensitive.
- If you enter in "PWD" window and if you want exit from that password change mode press 'ESC'.
- By Default Password is "masibus".

**10) "SD" command:**

- Press "SD" to set Default all Parameters:
- By entering "SD" followed by Enter, it will set all Parameters.

**11) "L" command:**

- Press "L" to View Current all Parameters:
- By entering "L" followed by Enter you will get below image

```

L
*****
List Of Current Parameters
*****
Baud Rate      :9600
Stop Bit       :1
Parity Bit     :None

IP Address      :192.168.100.032
Subnetmask     :255.255.255.000
Gateway        :192.168.100.001
Primary Server IP Address :192.168.100.153
Secondary Server IP Address :192.168.100.154
Query Interval Time[When Querying NTP Server] :0016
Query Request Time out :02
Query Retry Interval :02
Number of Time outs Before switching Servers :03
Secondary Server option for NTP :Disable
SNMP Manager IP1 :192.168.100.226
SNMP Manager IP2 :192.168.100.226
SNMP Write Community :masibus
SNMP Read Community :masibus

Display Type   :Time Display
Date Format     :DD/MM/YY
Time Format     :24 Hour Time Format

Time Zone Offset      :+05:30
Time Zone Offset For NTP :Enable
Time Zone Offset For SERIAL :Enable

Press H For Help Menu
Press Q To Exit
    
```

**12) “CS” command:**

- Press “CS” to View Current all Parameters:
- By entering “CS” followed by Enter you will get below image

```

CS

Current Sync Status : Sync With NTP(Primary Server)

Press H For Help Menu
Press Q To Exit
    
```

- This Command will print Current Sync with information.

**6.2.5.3 Important Points for Serial Configuration**

- Digital Display Unit’s Serial Configuration has timeout period of 2 minutes. If you do not press any character till 2 minutes, the session will be automatically closed with a message of Timeout, Session Closed.
- Commands are case insensitive, only Password is Case sensitive.

**6.2.6 Configuration command through Master (GPS-MC-2) Over Wireless:**

- DDU-TM-44/46 or DDU-44/46 offers facility to the users for configuring communication parameters of serial port, Display Format Selection, Time Zone Selection, Manual Time Set, Set Default Parameter, Retransmission selection set by Key or configuration Frame Sent by master GPS-MC-2 over Wireless and View Current Settings by Key Configuration.
- Error Message code Can be Display when any Error Found in received Configuration frame from Master (GPS-MC-2) over Wireless. Show the Table 5 for Error message display code
- User can see the Slave ID of Unit in Run Mode by sending reset command through Master(GPS-MC-2)
- If Slave ID does not match with Received Frame then lower digit of second and Lower digit of month or Year DP Blinking Started for 2 second.

**Table 5 Error Message Display Code**

Er.01	Display Mode
Er.02	Time Mode
Er.03	Date Mode
Er.04	Time Zone Offset set Mode
Er.05	Baud Set mode
Er.06	Stop set Mode
Er.07	Parity set Mode
Er.08	Retransmission Mode
Er.09	RF Frame Transmit Channel set Mode
Er.10	RF Frame Receive set Mode
Er.11	Unlock Blinking set Mode
Er.12	Slave ID
Er.13	Show Slave ID Error Command

**Note:** 1) Er.03 code Display in DDU-46 when you will try to set Date Mode YY.MM.DD Format.

## 7. OPERATION INFORMATION

### 7.1 Operation as Time/Date Display [DDU-TM-44/46 or DDU-44/46]

1. Insert the power cord into an appropriate connector inside the clock.
2. Upon Power up of DDU-TM-44/46 or DDU-44/46, The Unit display Slave id Then if unit is wireless input model then it display the RF receive channel and transmit channel that you are set. Then it will start displaying time/date from internal RTC otherwise it will start displaying time/date from internal RTC. After synchronization with master clock, it will take & display the time/date of master device. DDU-TM-44/46 or DDU-44/46 clock will start display RF receive channel 0 and then start from 00:01:00 and 01/01/15, during first time Power ON & run on internal RTC until synchronizes with master clock.
3. **RS232/485 Signal as Input:**

There is auto frame detection mode is given in DDU-TM-44/46 or DDU-44/46, so no configuration is required for frame input selection. Connect a source of Serial Communication of GPS to the input serial connector of DDU-TM-44/46 or DDU-44/46. The time should appear on the display within 60 seconds of application of time code. If the time code signal is lost or disconnected, then DDU-TM-44/46 or DDU-44/46 will continue to display time based on its internal RTC, until the time code signal is returned.
4. **Wireless Input:**
  - Set RF receive channel in DDU-TM-44/46 or DDU-44/46, on which channel Wireless master transmitting the time code signals. You can set receive channel between 0-9 and auto. Auto option will scan automatically on which channel wireless transmitter transmitting the time code frames.
  - If you are select Auto mode in RF receive channel and then after unit power on it will display RF receive channel which unit previous lock in auto mode.
  - DDU-TM-44/46 or DDU-44/46 will catch the signal from around 100 meters area with obstacles in case of master to slave communication or 50 meters in case of DDU-TM-44/46 or DDU-44/46 to DDU-TM-44/46 or DDU-44/46 slave communication.
  - DDU-TM-44/46 or DDU-44/46 has option of Re-transmission of received signals, set RF transmit channels between 0 to 9, and DDU-TM-44/46 or DDU-44/46 will transmit the received signals on set channel, for increasing the Range. If you do not want to re-transmit then set no option in RF-T key configuration menu.
  - For Wireless Input Refer [**see Communication Guidelines Section**]
5. **ETHERNET as Input:**

Connect the RJ-45 cross cable between Ethernet port of DDU-TM-44/46 or DDU-44/46 & NTP Server. Ethernet Client settings for DDU-TM-44/46 or DDU-44/46 will be done by telnet.

  - Open the Telnet configuration window as explained in Section 6.2.4 of Configuration. Now Enter the I.P. address of NTP time source Server[Primary and secondary server], MASK, Gateway, and **Query interval time, Query request time out, Query Retry time , Number of time out counts** before switching servers from which you want to take reference time. After configuration close the Telnet window.
  - DDU-TM-44/46 or DDU-44/46 will first send query to the primary NTP server (@ every **Query interval time**) for Time code if it get response it will Lock on primary NTP server, but till the set time of Request time out it does not get response, it again send query to the primary NTP server after Retry Interval time, DDU continues try to send query after every Request time out + retry time, up to set number of counts before switching servers, after it DDU shows Unlock indication on the display for set Query interval time & after that time it will send Query to secondary NTP server when Secondary Server Option For NTP is Enabled for Time frame, if it gets Query reply from Secondary NTP server than it will get lock,
  - While synced with secondary NTP server DDU will send Query primary NTP server 6 seconds before set query interval time & wait 1 second for NTP query reply
  - If there is no reply from Primary than after 2 seconds it will send query to secondary NTP server.
  - Above Primary NTP server availability check will happen before every scheduled query interval time
  - If it get NTP query reply from primary NTP server than it will shift on Primary Server with Lock condition & start working continuously on primary NTP server

- On availability of both NTP Servers , DDU gives priority to Primary and make the query after ever set Query Interval time , on not availability of Primary NTP Server , it shift on Secondary Server and continuously check for primary NTP server.
6. Connect master clock Ethernet output to RJ-45 Ethernet connector of DDU-TM-44/46 or DDU-44/46. The time should appear on the display within 60 seconds of application of time code as DDU-TM-44/46 or DDU-44/46 synchronizes at every Query Interval time seconds with time source. If the time code signal is lost or disconnected, then DDU-TM-44/46 or DDU-44/46 will continue to display time based on its internal RTC, until the time code signal is returned.
7. **RS232/485 Signal as Output[for with Wireless model]:**
- If you are selected to transmit NMEA-0183[RMC] Format output frame only the Time and Data field is Present and remaining Data Field transmitting as Zeros from the DDU-TM-44/46 or DDU-44/46 with help of selection in retransmitting configuration.
  - If you are selecting **Σερ** and **Βοηη** option in retransmission configuration then it working as output terminal.

**NOTE: If DDU-TM-44/46 or DDU-44/46 is in sync using Serial [RS232/RS485] than do not use Serial [RS232/RS485] for Retransmission.**

8. **Wireless Output:**
- If you are selected to transmit Wireless output frame from the DDU-TM-44/46 or DDU-44/46 with help of selection in retransmitting configuration.
  - If you are selecting **ΡΦ** and **Βοηη** option in retransmission configuration then it Transmitting Wireless output Frame.
  - Then you have to select RF transmit channel which for Transmitting Wireless Output Frame. This unit work as Master Clock for other unit which is Synchronize with this Unit in the range of it.
9. If the clock is unable to achieve a time code lock see the section entitled **Troubleshooting Tips**.
10. For Serial Communication time codes date must be encoded to the standard specification. These specifications are also supported by *Masibus* Master Clock systems [**see Communication Guidelines Section 8.2**].

#### 7.1.1 Lock/Unlock Indication for Time/Date Display

- The colons of the clock display will flash if the time displayed is not locked to time code of GPS when user set **BL10**, **BL05** , **BL02** or **bl1di** in unlock configuration. This option will be available in wireless model only
- When time code is present and decoded properly the colons or Whole Display will remain steady-on.
- You can enable or Disable blinking of colon's and DP or Blink Whole Display of Time and Date in unlock condition using Key configuration as shown in section 6.2.3.11.  
- In case of Date in place of colons "dp" after 2<sup>nd</sup> digit will provide lock/unlock information, if User set **BL10**, **BL05** or **BL02** in unlock configuration.
- The Whole Display of Time and Date will be blink in unlock condition by selecting **BLDI** option in unlock configuration.
- In NTP with Serial Model user can set **BLon** and **BLoF** option. The unlock status will display if NTP Query will not resolved.
- In NTP with Serial Model, The Default unlock Time out is 1 Minute for Serial synchronized DDU

#### 7.1.2 AM/PM Indication for Time Display

- If the DDU-TM-44/46 or DDU-44/46 is configured for a 12-hour time display mode an AM/PM indicator will appear in the top left corner of the display during the PM hours. You will find decimal point **ON** when clock will be in PM hours in 12-hour mode.

#### 7.1.3 Display Format

- In DDU-TM-44/46 or DDU-44/46, have 3 option configurable
  1. Time Display
  2. Date Display
  3. Alternate Date & Time Display, which Display Both Time and Date Display. Date will be displayed at 18-20 seconds, 38-40 seconds and 58-60 seconds. These Display settings can be done by Key Configuration.



- There are two Time Format selectable
  2. 12 hour format
  3. 24 hour format
- The Date format given for Display
  - For DDU-TM-44/DDU-44:
    1. DD/MM
    2. MM/DD
  - For DDU-TM-46/DDU-46:
    1. DD/MM/YY
    2. MM/DD/YY
    3. YY/MM/DD
- In DDU-TM-44/46 or DDU-44/46, there is one option of enable or disable the blinking of Colon and DP in unlocking condition.

#### **7.1.4 Serial Port Settings**

- In DDU-TM-44/46 or DDU-44/46, for serial port, there are 2 Baud rate given configurable.
  1. 9600
  2. 19200
- Parity Bit can be configurable as Even ,Odd or None
- Stop Bit can be configurable as 1 Stop bit or 2 Stop bit
- All settings can be set by Key Configuration as shown in section 6.2

#### **7.1.5 Time Zone Offset Settings**

- In DDU-TM-44/46 or DDU-44/46, Configurable Time Zone option is given.
- User Can Set Standard Time zone offset between +12:00 to -12:00.
- All settings can be set by Key Configuration as shown in section 6.2

#### **7.1.6 Manual Time Settings**

- In DDU-TM-44/46 or DDU-44/46, if there is no Time frame input available, at that time user can enter Manually Time and Date, Manual Time set can be done by using Key configuration as shown in section 6.2.
- This only available in Unlock condition and in lock condition, it will display LOCK, on display and did not allow entering in this mode.

## 8. COMMUNICATION GUIDELINES

### 8.1 Serial Time Frame Input

#### 8.1.1 NMEA-0183[RMC] Format

The \$GPRMC sentence contains time and date of position fix, speed and course information. The following examples show the contents of a typical RMC sentence:

The settings for this serial format is 9600, 8, N, 1.

The full data message of this format shall consist of data fields as follows:

**Table 6 NMEA-0183[RMC] Format**

Field	Example	Comments
Sentence ID	\$GPRMC,	
UTC Time	130525.00,	hhmmss.ss,
Status	A,	A = Valid/V = Invalid,
Latitude	4250.5589,	ddmm.mmmm,
N/S Indicator	S,	N = North/S = South,
Longitude	14518.5084,	dddmm.mmmm,
E/W Indicator	E,	E = East/W = West,
Speed over ground	000.1,	Knots,
Course over ground	245.0,	Degrees,
UTC Date	291206,	DDMMYY,
Magnetic variation	,	Degrees,
Magnetic variation	,	E = East/W = West,
Checksum	*25	*CC
Terminator	<CR><LF>	Non-printing characters

#### 8.1.2 NGTS Format

The settings for this format are programmable. The full data message of NGTS format shall consist of 14 printable characters and a concluding CRLF as follows:

**Table 7 NGTS Format**

Description	Number of Characters	Character Position	Range of Value/Information
Code Identification	1	1	Capital T
Year in Century	2	2,3	0 to 99
Month	2	4,5	1 to 12
Day of Month	2	6,7	1 to 31
Day of Week	1	8	1 to 7
Hours	2	9,10	0 to 23
Minutes	2	11,12	0 to 59
GMT Marker	1	13	0 or 1
Validity Marker	1	14	0 or 1
CRLF	2	15,16	Non-printing character

The transmission sequence shall be from the Code Identification character through to the CRLF with the most significant digits being transmitted first.

The message shall become automatically available at one second prior to the clock minute epoch.

### 8.1.3 T-Format

The settings for this format are programmable. The full data message of T-format shall consist of 21 printable characters with a concluding CRLF as follows:

**Table 8 T-Format**

Description	Number of Characters	Character Position	Range of Value/Information
Code Identification	1	1	Capital T
Divider	1	2	:
Year in Century	2	3,4	0 to 99
Divider	1	5	:
Month	2	6,7	1 to 12
Divider	1	8	:
Day of Month	2	9,10	1 to 31
Divider	1	11	:
Day of Week	1	12	1 to 7
Divider	1	13	:
Hours	2	14,15	0 to 23
Divider	1	16	:
Minutes	2	17,18	0 to 59
Divider	1	19	:
Seconds	2	20,21	0 to 59
Divider	1	22	:
GMT Marker	1	23	0 or 1
Validity Marker	1	24	0 or 1
CRLF	2	25,26	Non printing character

## 8.2 Wireless Time Frame Input

### 8.2.1 Wireless Clock Network

- DDU-TM-44/46 or DDU-44/46 designed to create mesh network protocol to increase the range of DDU-TM-44/46 or DDU-44/46 network as shown in fig 25.
- As shown in fig 25, there is Wireless master connected with GPS, which transmit the GPS time code in 866 MHz frequency. Wireless master will transmit data on 0 RF channel, so please set RF receive channel 0 on DDU-TM-44/46 or DDU-44/46, all slave DDU-TM-44/46 or DDU-44/46 will get lock which are in range of Wireless Master. As shown in figure S1, S2 and S3 are all in range of master so it will be directly connect with master.
- Slave device S4 is out of range from Wireless master so; it will not connect with master. It will in the range of Slave clock S1 it works as master clock. Slave device S4 is Synchronize with S1 clock.
- Slave clock 7 and 8 in the range of Slave clock 5 and Slave clock 6 it works as master clock. This two clock synchronize with respective Master clock.
- In DDU-TM-44/46 or DDU-44/46 we have given option of re-transmission of Received signal on configured channel using key configuration, please refer section 6.2 for RF – transmit and receive channel configuration.
- So please set S1, re-transmission on channel 1, S2 on Channel 2, S3 on channel 3, so you can connect more slave devices(Slave to Slave Delay <=1s) using this mesh protocol created by DDU-TM-44/46 or DDU-44/46.

### 8.2.2 DDU-TM-44/46 or DDU-44/46 Re-Transmit Option Details

- For increasing the network range and for creating the mesh network, DDU-TM-44/46 or DDU-44/46 has option of re-transmission of received signal using key configuration.
- You can configure 1-9 RF transmit channel and in case of you do not want re-transmit the signal please select no option in key configuration.

**Figure 27 Wireless Network of DDU-TM-44**

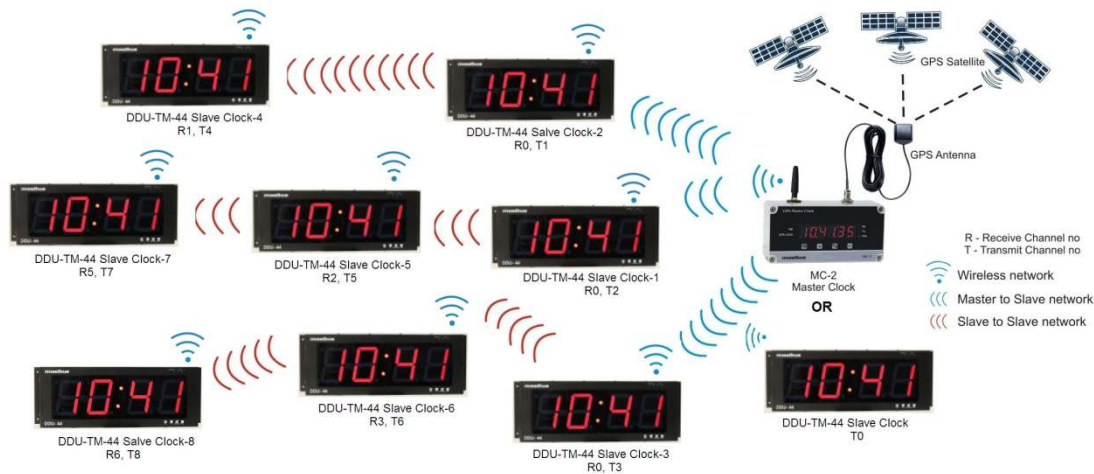

Note: - Wireless network of DDU-44 and DDU-TM-44/46 is same as DDU-TM-44.

**8.2.3 DDU-TM-44/46 or DDU-44/46 Receive Option Details**

- In DDU-TM-44/46 or DDU-44/46 you can set RF – receive channel between 0 – 9 and auto option.
- There are two options one is manual option and other is auto options for receive the RF signals.
- IF you set receive channel between 0 – 9 in manual mode in this mode DDU-TM-44/46 or DDU-44/46 will only try to receive the signals from configured channel between 0-9.
- If you select Auto option then it will be configured as auto mode, in this mode, at every power on DDU-TM-44/46 or DDU-44/46 will first try to sync on last stored RF channel, it will try for 9 minutes to sync with last stored channel.
- Till After 9 minutes if it fails to get sync with master or slave it will start RF channel scanning from channel 0 to 9, for each channel it will wait for 1 minute and in that minute if it does not get sync it will increase the channel, same logic will be applied for 0-9 channels.
- In Channel scanning mode if it get sync on any channel, that channel will be stored for communication.

**8.3 Wireless Configuration Frame Input**

- The User can change or update configuration menu by sending configuration frame from Master (GPS-MC-2) over wireless. Refer section of 6.2.3

**8.4 NTP Packet format:**

**Figure 28 NTP packet header format**

0	8	16	24	31
LI	VN	Mode	Stratum	Poll
Precision				
Root Delay (32)				
Root Dispersion (32)				
Reference Identifier (32)				
Reference Timestamp (64)				
Originate Timestamp (64)				
Receive Timestamp (64)				
Transmit Timestamp (64)				
NTP Message Header				

Following is the description of each parameter in NTP Packet:

**Leap** 2-bit integer warning of an impending leap second to be inserted or Deleted in the last minute of the current month, coded as follows:

- 0 no warning
- 1 last minute of the day has 61 seconds
- 2 last minute of the day has 59 seconds
- 3 alarm condition (the clock has never been synchronized)

**Version.** 3-bit integer representing the NTP version number.

**Mode** 3-bit integer representing the mode, with values defined as follows: 4 server

**Peer clock stratum** 8-bit integer representing the stratum, with values defined as follows:

- 0 unspecified or invalid
- 1 primary server (e.g., equipped with a GPS receiver)
- 2-255 secondary servers (via NTP)

**Polling interval** can be set between 16 to 60; it is representing the maximum interval between successive Queries.

**Clock precision** 8-bit signed integer representing the precision of the system clock. GPS is having clock precision of 1 us (1 microseconds = 0.000001s)

**Root Delay** Total roundtrip delay to the reference clock, in NTP short format.

**Root Dispersion** Total dispersion to the reference clock, in NTP short format.

**Reference clock ID** 32-bit code identifying the particular server or reference clock. GPS Global Positioning System

**Reference clock update time** when the system clock was last set or corrected, in NTP timestamp format.

**Originate timestamp** Time at the client when the request departed for the server, in NTP timestamp format.

**Receive timestamp** Time at the server when the request arrived from the client, in NTP timestamp format.

**Transmit timestamp** Time at the server when the response left for the client, in NTP timestamp format.

**Figure 29 NTP Timestamp Format**

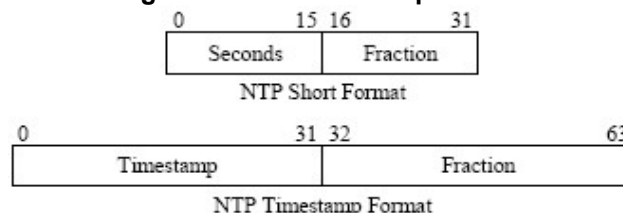

Follow [www.ntp.org](http://www.ntp.org) for more details for NTP Time Format and Client Settings.

## 8.5 SNMP Protocol

The Simple Network Management Protocol (SNMP) has been created to achieve a standard for the management and monitoring different devices connected on the same network from some remote location. SNMP has SNMPv1 and SNMPv2c standards available. SNMP is operating on the application layer and uses different transport protocols (like TCP/IP and UDP), so it is network hardware independent. SNMP protocol is having client-server architecture, where server is called as agent and client called as manager.

DDU CLOCK device supports and operates as SNMPv1 / SNMPv2c client, designed especially to handle SNMP requests for model DDU 44/46 specific status information of DDU Clock. SNMP agent is also capable of handling SET requests in order to manage the configuration via SNMP, if SNMP management software is also supports this feature. User need to configure SNMP manager IP address using Telnet command.

The elements (objects / variables) are organized in data structures called Management Information Base (MIB).The agent is also responsible for controlling the database of control variables defined in the product's MIB.

### 8.5.1 SNMP Addressing:

SNMP addressing is structured as a very large tree database. A root node address is an integer value That ranges from 0 to some very large number. Conceptually, there are no limits to the numbers of sub Nodes either. SNMP addressing is written in "dotted decimal" notation. For example, the address of DDU CLOCK product name Enterprise MIB variable is "1.3.6.1.4.1.38306.1.1.0", this is also known as OID (Object Identifier). The address fragment 1.3.6.1.4.1 is fixed by the IANA (Internet Assigned Number Authority) and is the address of the SNMP Private Enterprise MIB's. The 38306 is the address Assigned by IANA to masibus for our Enterprise MIB's. masibus assigns the addresses after that at Our discretion and design.

### 8.5.2 Protocol Detail

SNMP operates in the Application Layer of the Internet Protocol Suite. The manager may send requests from any available source port to port 161 to the agent. The agent will response back to the manager address on port 162. The manager receives notifications (Traps and Inform-Requests) on port 162. SNMPv1 specifies five core protocol data units (PDUs). Two other PDUs, Get-Bulk-Request, and Inform-Request were added in SNMPv2. The seven SNMP protocol data units (PDUs) are as follows:

1. Get-Request: This PDU is used to get the values of a list of variables from a Particular host.
2. Get-Next-Request: This PDU is used to get the next value for multi-valued data-items (for example the entries in a routing table). The manager specifies one or more variables for value, and the agent returns the current value for each of the requested variables.
3. Set-Request: This PDU is used to set the values of a list of variables for a particular host.
4. Get-Bulk-Request: This PDU is optimized version of Get-Next-Request, used to request multiple iteration of Get-Next-Request. It allows the caller to specify – non-repeaters, range of variables which are single valued, max-repetition, no of values to be returned by the call.
5. Response: Agent returns this PDU in response to above all PDUs. It contains the requested data items along with a result code.
6. Trap: This PDU is quite different from other PDUs. Agent generates it in response to particular important events. An agent only at the request of an SNMP manager application generates a trap PDU.
7. Inform-Request: This PDU introduces a new pattern of communication (Manager to Manager communication). In manager to manager communication, one manager sends information from a MIB view to another manager.

### 8.5.3 SNMP Operation:

DDU CLOCK model can work as SNMPv1 and SNMPv2c agent. SNMP Read and Write community used to monitor as well as configure SNMP parameters of model DDU 44/46 from some remote location. Read and Write community of model 24/26 agent is same for both SNMPv1 and SNMPv2c. model DDU 44/46 model supports max 2 SNMP managers.

- **Read Community:** SNMP manager must know Read Community of DDU CLOCK agent to monitor model 24/26 from remote location. DDU CLOCK model supports 20 character length of Read community. It can be modify using Telnet or SNMP Configuration. For Telnet configuration refer 11.1. Once Read community modified manager needs to remember for further use. Factory set Value: masibus
- **Write Community:** SNMP Manager must know the Write community of DDU CLOCK agent to configure SNMP parameters. Model 24/26 model supports 20 character length of Write Community. It can be modify using Telnet or SNMP Configuration. For Telnet configuration refer 11.1. Once write community modified manager needs to remember for further use. Factory set Value: masibus
- **Trap Receiver IP Address:** Trap Receiver IP Address also known as SNMP manager IP address. SNMP manager IP address must be configure to receive asynchronous event like model DDU 44/46 synchronized / Not Synchronized via Traps. SNMP manager IP address can be configure using Telnet or SNMP Configuration. Factory set value of both SNMP managers are same. Factory set Value: 192.168.100.226

- **Trap Enable:** Trap enable field in OID is 1.3.6.1.4.1.38306.2.1.1.2 must set to 1 to enable trap generation for manager IP. By default Trap Enable variable is enabled to generate traps. Factory set Value: 1 (Enable to generate Traps)

	<ul style="list-style-type: none"> <li>• SNMP manager's IP address must be configured to receive asynchronous traps.</li> <li>• Please note that particular trap will only be sent if that parameter is configured for trap by Trap enabled option through SNMP.</li> </ul>
---	---

DDU CLOCK can be configured via several user interfaces. Besides the possibility to setup parameters of SNMP using direct shell access via Telnet, SNMP based configuration is also available. In order use the SNMP configuration, you need to fulfill the following requirements:

1. CLOCK Time Sync Unit 44/46 model MIB file must be present as well as included on the client software.
2. Write community of the client software and CLOCK model 44/46 model must be the same. The mentioned MIB file can be found from the CD enclosed with the model DDU 44/46 model or you can contact masibus support team at support@masibus.com. For reference here, we have used Ireasoning MIB browser. Below are the steps to configure model DDU 44/46 using SNMP.

**Note:** This SNMP software is free edition software and it is used for testing purpose.

2. Load MIB file to Browser:

Install MIB browser from Ireasoning

Open Browser from: Start-> All Programs-> iReasoning-> MIB Browser.

Unload All MIB files from: File ->Unload MIB

Now load masibusDDUClock.mib from: File ->Load MIB-> Path where file is saved.

You can find that MIB file is loaded in SNMP MIBs column.

**Figure 30 MIB Browser**

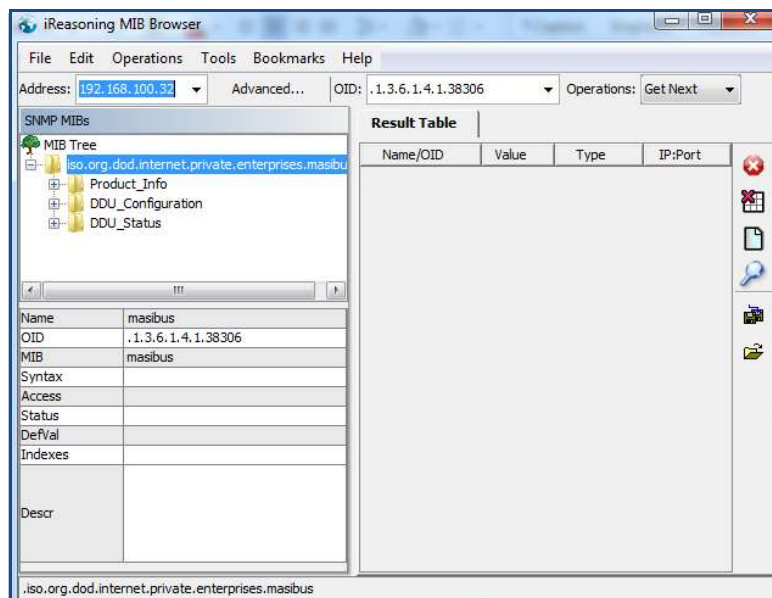

2. Enter DDU44/46 Clock IP address in Address box of MIB Browser. Enter IP address in format XXX.XXX.XXX.XXX
3. Enter Community/ SNMP version/ Port:

**Port:** 161

**Read Community:** masibus (Factory set Value)

**Write Community:** masibus (Factory set Value)

**SNMP Version:** 1 or 2 (Select from Dropdown menu)

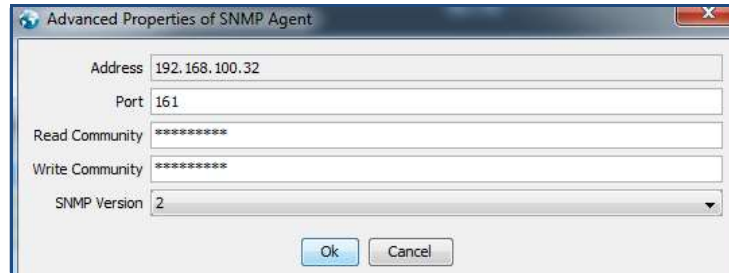

**NOTE:** Above value of Read & Write, community is factory set, once they configured SNMP manager Need to remember to operate or monitor from remote location.

#### 4. MIB Tree view:

The MIB of the masibus model DDU\_CLOCK includes following part:

SNMP Object &OID	Name & OID	Value	Description
Enterprises.38306	masibus 1.3.6.1.4.1.38306	-	Root Node of The masibus MIB
masibus.1	Product_Info 1.3.6.1.4.1.38306.1	String	masibus model DDU clock Product information
masibus.2	DDU_Configuration 1.3.6.1.4.1.38306.2	String	masibus model DDU clock SNMP configuration variable
masibus.3	DDU_Status 1.3.6.1.4.1.38306.3	String	masibus model DDU clock Status variables

#### SNMP Object Product Info variables

SNMP Object &OID	Name & OID	Value	Description
Product_Info	Name 1.3.6.1.4.1.38306.1.1.0	String (R)	A read Only variable display Name of Product
Product_Info	Version 1.3.6.1.4.1.38306.1.2.0	String (R)	A read Only variable display Firmware Version
Product_Info	Date 1.3.6.1.4.1.38306.1.3.0	String (R)	A read Only variable display Firmware Release Date

#### SNMP Object DDU\_Configuration variables:

SNMP Object &OID	Name & OID	Val	Description
DDU_Configuration	Traps 1.3.6.1.4.1.38306.2.1	N.A	Not Accessible
Traps	TrapEntry 1.3.6.1.4.1.38306.2.1.1	N.A	Not Accessible
Trap Entry	TrapReceiverNumber 1.3.6.1.4.1.38306.2.1.1.1	Integer(R) (0-1)	A read Only variable indicating no of SNMP manager supported by model DDU Clock Agent
Trap Entry	TrapEnabled 1.3.6.1.4.1.38306.2.1.1.2	Integer(R/W) (0-1)	Enable/Disable reception of traps to the SNMP manager. 0 – Disable Traps 1 – Enable Traps
Trap Entry	TrapReceiverIPAddress 1.3.6.1.4.1.38306.2.1.1.3	String(R/W)	SNMP Manager IP address (IPv4)
Trap Entry	Trap Community 1.3.6.1.4.1.38306.2.1.1.4	String(R/W) (1 – 20 Characters)	Trap Community
DDU_Configuration	Read Community 1.3.6.1.4.1.38306.2.2.0	String(R/W) (1 – 20 Characters)	SNMP Community which has Read-Only Access can be only used to monitor status variables and configuration values.
DDU_Configuration	Write Community 1.3.6.1.4.1.38306.2.3.0	String(R/W) (1 – 20 Characters)	SNMP Community which has read-write access, can be used to monitor status variables and Get/Set SNMP configuration parameters



SNMP Object DDU\_Status variables:

SNMP Object &OID	Name & OID	Val	Description
DDU_Status	DDU_Status 1.3.6.1.4.1.38306.3.1.0	Integer (R) (0-1)	Variable indicating masibus model DDU Clock Synchronized / not Synchronized 0 - Not Synchronized 1 – Synchronized
DDU_Status	DDU_Status 1.3.6.1.4.1.38306.3.2.0	String (R) (1 - 8 Characters)	Variable of string indicating Current masibus model DDU Clock Time in hh:mm:ss format
DDU_Status	DDU_Status 1.3.6.1.4.1.38306.3.3.0	String (R) (1 – 10 Characters)	Variable of string indicating Current masibus model DDU Clock Date in dd/mm/yy format
DDU_Status	DDU_Status 1.3.6.1.4.1.38306.3.4.0	String (R) (1 – 11 Characters)	DDU Sycc with Primary server or secondary server 1 –for Primary server 2- for secondary server

5. Get / Get Next / Get Bulk / Set / Walk Command:

**Figure 31 GET Command of MIB Browser**

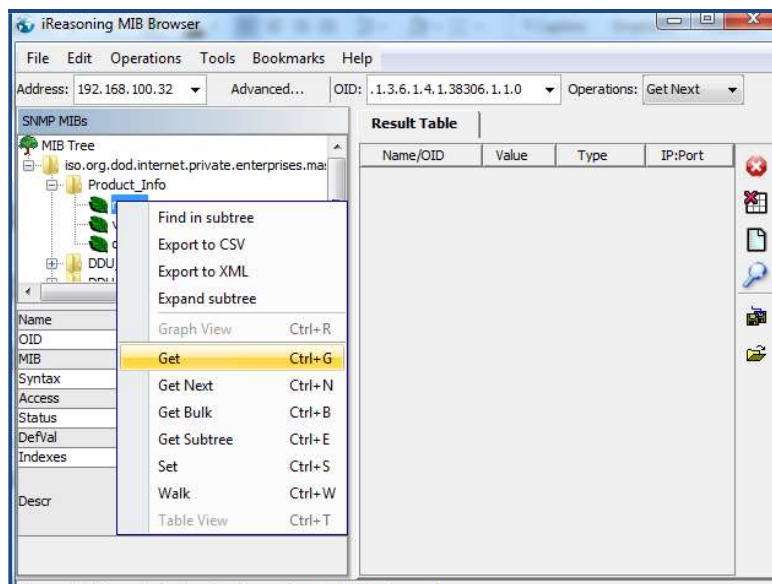

To perform any of Get / Get Next / Get Bulk / Set / Walk command you need to first select variable (corresponding OID).

#### 8.5.4 SNMP Traps

DDU Clock can send SNMP traps maximum up to two SNMP managers if configured. Factory set status of Trap Enable variable is 1 meaning DDU Clock is enable to generate traps for SNMP Managers. DDU Lock status in DDU status tree show the sync status of DDU clock. It shows the value 1 for synchronized or 0 for unsynchronized status.

#### 8.6 Serial Time Frame Output

- DDU-TM-44/46 or DDU-44/46 Transmit only NMEA-0183[RMC] Format same as Input of NMEA-0183[RMC] Describe in section 8.1.1.
- The Output Format Frame shell consist of only Time and Date data Field provided other field or shell transmitting as zero.
- By Default the settings for this serial format is 9600, 8, N, 1.

## 9. TROUBLESHOOTING TIPS

If the operating display does not appear after turning on the controller's power, follow the measures in the procedure below.

If a problem appears complicated, contact our Customer support representative.

### **IMPORTANT**

Take note of the parameter settings when asking the vendor for repair.

Time Code decoding problems can include any of the following:

- No Time Code present
- Ground loops or other interference such as coupling from nearby AC power lines, bad/intermittent cables, wiring or connectors incorrect wiring connection for unbalanced or balanced input signals
- Out of range signal level that is too high or too low
- Fluctuating signal level
- A signal that is distorted
- A Time Code frame that your clock does not support
- In case of Wireless input, distance between Wireless master and slave is too far from Master so slave cannot get the time code signal.

**Problem:** Clock is unable to "Lock" to time code after 2 minutes.

#### **Possible reasons/solutions:**

##### **For Incase of Serial Input:**

1. Verify that GPS master's Baud rate, stop bit and parity bit are same as in DDU-TM-44/46 or DDU-44/46.
2. Check all the input signals voltage level for DDU-TM-44/46 or DDU-44/46 synchronization. E.g. RS232 – approx. 10.4 V DC, RS-485 – Varies between 0-5 V DC. Here these voltages are measured with multi meter. This is not the exact voltage level of any signal but this gives ruff idea about signal presence on port.
3. The time code being fed to the DDU-TM-44/46 or DDU-44/46 must be recognized format. Verify that your time code source is providing one of the time code formats that the DDU-TM-44/46 or DDU-44/46 can decode & match its frame length as per standard.

##### **For Incase of Wireless Input:**

4. Check the RF Receive channel is same as the Wireless master's Transmitting channel or DDU-TM-44/46 or DDU-44/46 in Auto mode.
5. If you are trying to sync DDU-TM-XX with Wireless mater , then check they are not out of range , both unit must be in range of 100 meter area , and if you are trying to sync DDU-TM-44/46 or DDU-44/46 with DDU-TM-44/46 or DDU-44/46 , slave to slave communication , then it must be in range of 50 meter area.

**Problem:** Not displaying the correct local time and/or date.

#### **Possible reasons/solutions:**

1. For Serial communication: NGTS & T format supports IST only and so there is no requirement of Time Zone offset, please enter 00:00 in Time Zone offset.  
In case of NMEA (\$GPRMC) frame format and Wireless input they are supporting UTC time so , enter time zone offset as per your local time zone offset.
2. If LED in DDU-TM-44/46 or DDU-44/46 blinks after the time zone configuration done in DDU-TM-44/46 or DDU-44/46, reset the power of the DDU-TM-44/46 or DDU-44/46 is must for effective synchronization.
3. Your Time Code source is not providing the time and/or date that you expect. Contact the individual responsible for the Time Code source for more information

**PROBLEM:** UTC time and/or date is incorrect.

#### **There are several potential failure points:**

- Invalid, intermittent or missing Time Code source
- Date/year overwrite function for non-date encoded Time Code may be configured improperly
- Battery may need to be replaced

• A Local Time Zone configuration not set correctly

1. Verify that your Time Code source is generating the UTC referenced time and date that you expect and that this Time Code format is at an acceptable signal level and quality that can be detected at the client side (i.e. DDU-TM-44/46 or DDU-44/46 input).
2. If you are using in-house Time Code, verify that the Time Code source is locked to the GPS satellite system for UTC Time Code.
3. If your Time Code source is providing DST adjustments, Please Note that DDU-TM-44/46 or DDU-44/46, does not support any kind of DST adjustments.
4. If your Time Code source is providing Time Zone offsets these functions must be disabled in your DDU-TM-44/46 or DDU-44/46 in order to eliminate double offsets.

**PROBLEM:** Unit time show more than 2 second delay.

**Possible reasons/solutions:**

Unit has been show correct time (<1s delay) when received wireless frame then after it show delay (increment delay) time until next frame receive.

1. Check that unit receive frame from Multiple Master (more than one unit transmit frame on same transmit channel)
2. If you are not using unit as master then you select no option in Retransmission configuration.

**Problem:** Clock is unable to “Lock” to time code after 2 minutes.

**Possible reasons/solutions:**

1. Close the TELNET configuration window, if DDU-TM-44/46 or DDU-44/46 is under configuration over TELNET Protocol.
2. Use **Cross** CAT5 or equivalent cable for synchronization of DDU-TM-44/46 or DDU-44/46 with Master Clock / Desktop Computer.
3. Check the connectivity of DDU-TM-44/46 or DDU-44/46 in LAN using ping command. (if Ethernet as input)
4. For NTP + PoE model check connectivity between LAN and PoE injector and Display Unit and PoE injector.

**Problem:** Clock is unable to configure with received configuration frame from Master GPS-MC-2.

**Possible reasons/solutions:**

1. Make sure that Matching of Slave ID.
2. RF Receive Channel of Slave Clock is same as RF transmit Channel of Master GPS-MC-2.
3. When sending Configuration Frame then DP of Lower Digit of Minute or Slave Blinking or Not. If start Blinking Means the Slave ID does not match.

**Problem:** DDU-TM-44/46 or DDU-44/46 display Er.03 when sending configuration command From GPS-MC-2

**Possible reasons/solutions:**

1. DDU-TM/44 or DDU-44 does not support YY.MM.DD format it only display DD.MM or MM.DD format.
2. You can see the Table 4 for more understanding which type of Error is display.

**Problem:** Display Unit with NTP +PoE input Model is not Power on.

**Possible reasons/solutions:**

3. Check the Power cable of PoE injector is proper connected.
4. Check the CAT5 cable connected between display unit and PoE injector is proper connected.

**PROBLEM:** Clock is unable to find NTP reference.

**Possible reasons/solutions:**

1. Verify that the NTP server(s) specified are reachable, communicating, and are not flagging their reported time as invalid.
2. Verify that a gateway/router/firewall has been configured that allows the clock to communicate outside of its local network.

3. Verify that the IP address configured for the clock is correct. If you manually enter an IP address that already exists on the network, this will create an IP address conflict.
4. Obtain a new IP address for the clock or resolve the duplication. Consult your IT/Network Administrator for a list/range of available IP addresses to avoid IP address conflicts.
5. Verify that the clock is connected to the Ethernet LAN.
6. Verify that all network cables, hubs, etc. are in proper working order. Be sure that Ethernet crossover "patch cables" are not being used where inappropriate.

### TELNET Configuration for WINDOWS 7:

If TELNET window is not opening in windows-7 Operating System, then go to My Computer → Find window → write TELNET as shown in below Picture.

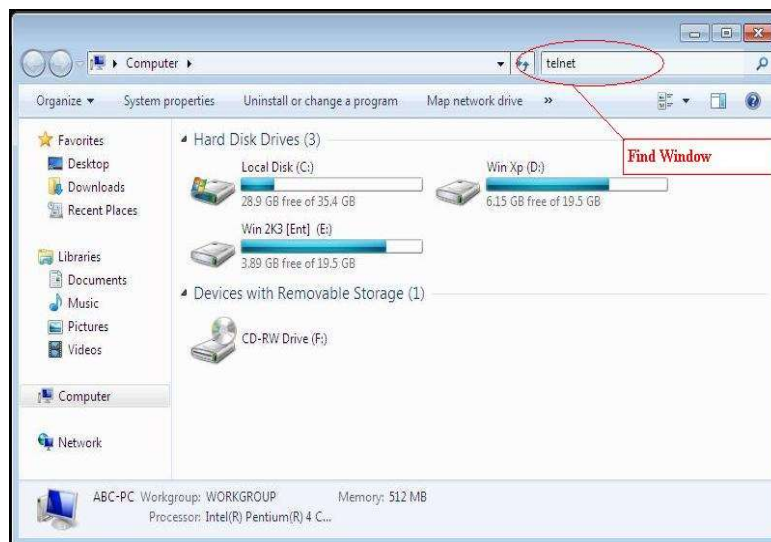

By Pressing enter you can see the TELNET file. By double clicking on that TELNET file it will open new window as shown in below figure.

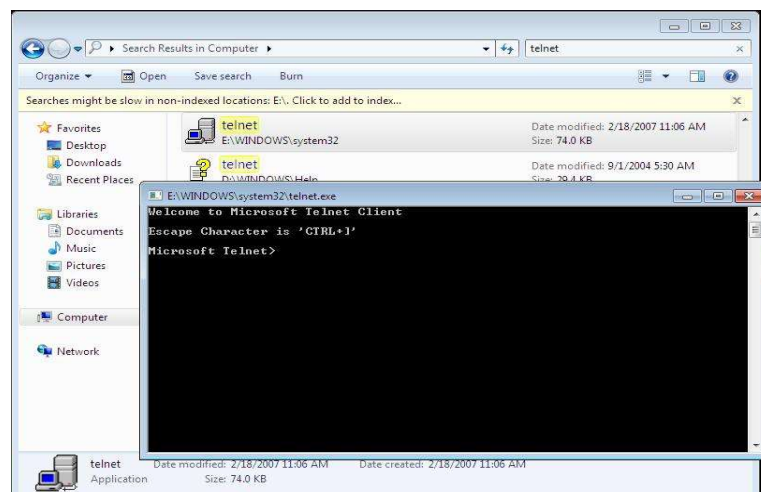

**If these troubleshooting tips do not solve your problem then, please contact Customer support at either nearest area office or Main Head Office as given on the first page.**

## REVISION HISTORY

---

Following Changes added in m06bom101-07 compared to m06bom101-06.

1. SNMP Configuration detail added.
2. Serial configuration detail added for Serial with NTP or PoE Model

### **Masibus Automation & Instrumentation Pvt. Ltd. Customer Support Division**

B/30, GIDC Electronics Estate,  
Sector-25, Gandhinagar-382024, Gujarat, India  
Ph: 91-079-23287275-77 Fax: 91-079-23287281  
Email: [support@masibus.com](mailto:support@masibus.com)  
Web: [www.masibus.com](http://www.masibus.com)