

OPERATOR'S MANUAL **GPS Time Sync Unit**

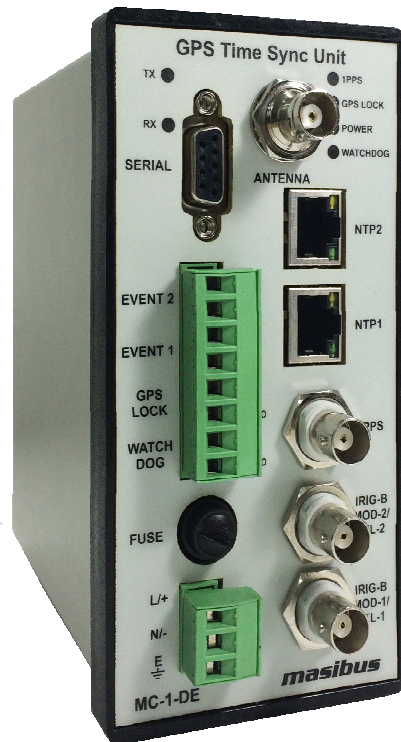

Masibus Automation And Instrumentation Pvt. Ltd.

B/30, GIDC Electronics Estate,
Sector-25, Gandhinagar-382044, Gujarat, India

☎ +91 79 23287275-79 📠 +91 79 23287281-82

Email: support@masibus.com

Web: www.masibus.com

CONTENTS

1. INTRODUCTION	5
Foreword	5
Notice	6
Limited Warranty	6
Trademarks.....	7
Product Ordering Code	7
2. Unpacking the MC-1-DE	8
2.1 Packing List	8
3. GPS Fundamentals	9
4. MC-1-DE Specification	11
5. Unit Front Panel Description	15
5.1 GPS TIME SYNC UNIT MC-1-DE Front Panel	15
6. GPS TIME SYNC UNIT MC-1-DE Installation	19
6.1 GPS Antenna and Cable Information	20
6.2 Unit Installation	25
6.3 Mechanical Dimensions	26
6.4 Wiring Diagram	27
7. GPS TIME SYNC UNIT MC-1-DE Power ON	28
7.1 Receiver Boot-up mode	28
7.2 Battery Backup RTC and GPS receiver RAM Configurations:	29
7.3 Startup Operation.....	29
7.4 Basic Normal Run Mode Operation	30
8. Serial Communication and Configuration	31
8.1 Serial Port Setup and Serial Cable Configuration	31
8.2 Configuration Commands	34
9. Timing Outputs – Serial, IRIG-B, NTP	47
9.1 Timing Output – Serial	47
9.2 Timing Output – IRIG-B	49
9.3 Timing Output – NTP	53
9.4 GPS Time Sync Unit NTP Output:	54
9.5 NTP Client Synchronization:.....	55

9.6 NTP Hierarchical Time Distribution:.....	56
10. Relay and Pulse Outputs.....	59
10.1 Relay Contact Outputs.....	59
10.2 Pulse Outputs.....	59
11. Ethernet Communications: Telnet, SNMP.....	61
11.1 Telnet	61
11.2 SNMP	62
12. Holdover Mode.....	68
13. Options.....	69
13.1 Optional Input Power Supply.....	69
14. Appendix List.....	70
15. Troubleshooting.....	71
16. Abbreviations	75

LIST OF FIGURES

Figure 1 Basics of GPS	9
Figure 2 GPS Time Sync Unit Model MC-1-DE Front Panel	15
Figure 3 Power Supply terminals.....	15
Figure 4 Fuse.....	16
Figure 5 Alarm Relay Terminals	16
Figure 6 Additional event Terminals	16
Figure 7 Serial Output Terminal	16
Figure 8 IRIG B Output Terminal	17
Figure 9 IRIG B Output Terminal	17
Figure 10 1PPS Output Terminal.....	17
Figure 11 NTP1 Output Terminal.....	18
Figure 12 NTP2 Output Terminal.....	18
Figure 13 Antenna Output Terminal.....	18
Figure 14 Antenna Mounting.....	21
Figure 15 Antenna Mounting with Lightning Arrestor.....	21
Figure 16 Wall Mount Mechanical Dimension Layout	26
Figure 17 Panel Mount Mechanical Dimension Layout	26
Figure 18 Din Rail Mount Mechanical Dimension Layout	27
Figure 19 Wiring Diagram of GPS Time Sync Unit.....	27
Figure 20 HyperTerminal	31
Figure 21 HyperTerminal new connections.....	32
Figure 22 RS-232 Male to Female cable connection.....	32
Figure 23 Hyper Terminal new connection configuration.....	33
Figure 24 Hyper Terminal Property configuration.	38
Figure 25 IRIG B Waveform	50
Figure 26 NTP Time Output	54
Figure 27 NTP Time distributions in Hierarchical Arrangement	56

LIST OF TABLES

Table 1 Antenna Mounting	25
Table 2 Ethernet Default command	41
Table 3 Default command.....	42
Table 4 NMEA Frame structure	47
Table 5 T- Format Frame Structure	48
Table 6 NGTS frame Structure	48
Table 7 Relay contact Output	59
Table 8 Configurable Parameters through Telnet.....	61

1. INTRODUCTION

Foreword

Thank you for purchasing GPS Time Sync Unit MC-1-DE .GPS Time Sync Unit is available in Din Rail Mount/Wall Mount/Panel Mount

This manual describes the basic functions and operation methods. Please read through this user's manual carefully before using the product.

masibus GPS TIME SYNC UNIT MC-1-DE has been developed to address key power and process industry timing requirements. Whether it's the monitor, control or analysis of the power system, the GPS TIME SYNC UNIT MC-1-DE is the cost-effective GPS time synchronization solution.

To begin with, the GPS TIME SYNC UNIT MC-1-DE offers superb timing accuracy using GPS satellites; it generates extremely accurate output pulses and time codes in multiple formats. It's necessary every time to Lock GPS once after power ON in order to ensure the better accuracy.

The GPS TIME SYNC UNIT MC-1-DE synchronizes a wide variety of microprocessor-based power system equipment including SCADA systems, remote terminal units (RTUs), protection relays, and sequence of event recorders, digital fault recorders, tariff meters, Slave Display Units, Data Loggers and other Intelligent Electronic Devices (IEDs) .Each Output can feed directly to different areas through electrically isolated ports which ensure reliable operation in a Harsh substation environment. Being a Field programmable device using HyperTerminal, a very common application in Windows, the GPS TIME SYNC UNIT MC-1-DE allows the user to alter the settings or choose from Time codes. The serial port (RS232/RS485 Factory configurable) is provided for that purpose. Each output can feed directly to different areas through electrically isolated ports which ensure reliable operation in a harsh substation environment.

The GPS TIME SYNC UNIT MC-1-DE generates a wide range of timing signals. Standard configurations of GPS TIME SYNC UNIT MC-1-DE is equipped with one serial ports, a 1PPS Port, 2 IRIG-B TTL /AM, TWO RJ-45 NTP terminal and Two relay outputs for WATCHDOG, GPS Lock alarm and Two additional PMOS relay based pulse outputs each configurable from a second to a day period time, IRIG-B127 or IEEE 1344/C37.118-2005 Amplitude modulated output, Serial Port is configurable for NMEA 0183, NGTS, and T- Format. Time synchronization protocol (NTP) standard as Server mode implemented in GPS TIME SYNC UNIT MC-1-DE to provide time synchronization to different slaves supporting NTP protocols (NTP v3, SNTP).

All GPS TIME SYNC UNIT MC-1-DE unit gives both installation teams and users visual feedback about the time data being generated on the outputs. LED indicators provide "at a glance" status information.

The optimized Receiver/Antenna system employed in the GPS TIME SYNC UNIT MC-1-DE provides time information from the GPS satellite constellation. Dynamic T-RAIM processing is used to eliminate any aberrant satellite signals from the timing solution. The result is timing precision on all outputs with accuracy similar to that normally seen only in laboratory instruments.

The GPS TIME SYNC UNIT MC-1-DE unit occupies the size 72mm(H) X 143mm(L) X 140mm(D) (IP 20 Enclosure). It is supplied complete with all hardware and software required for the installation, including the Antenna, Antenna mounting kit, 15 meters Antenna cable, .02 meter RS – 232 cable and 02 meters RG58 Co-axial cable. (Depends upon commercial terms & condition also as per order)

Notice

The contents of this manual are subject to change without notice as a result of continuous improvements to the instrument's performance and functions.

Every effort has been made to ensure accuracy in the preparation of this manual. Should any errors or omissions come to your attention, however, please inform MASIBUS Sales office or sales representative. Under no circumstances may the contents of this manual, in part or in whole, be transcribed or copied without our permission.

All description related to output ports are applicable if covered in ordering code.

Limited Warranty

Masibus Automation and Instrumentation Pvt. Ltd. Provides limited warranty for its manufactured product against the defects in material shipped, workmanship under normal use and service for the period of 12 months from the date of shipment of product. This warranty shall not apply if the product is used contrary to the instructions in its manual or is otherwise subject to misuse, abnormal operations, accident, lightning or transient surges, repairs or modifications not performed by Masibus Automation and Instrumentation Pvt. Ltd.

Necessary items packed with GPS Time Sync Unit such as antenna, lightning arrestor, antenna line amplifier and other accessories are also provided with limited warranty of 12 months from the date of shipment.

Masibus Automation and Instrumentation Pvt. Ltd. Obligation under this warranty is limited to in factory, service and repair, of the product or the component thereof, which is found to be defective. If the defect is found for which Masibus Automation and Instrumentation Pvt. Ltd. is not responsible for the defect or the cause of defect in product, the service or repair will be done on the charge basis, on which the buyer agrees.

For warranty service or repair, products if returned to a service facility at Masibus Head Office, buyer shall prepay all shipping charges to Masibus, and Masibus may pay shipping charges incurred in returning the product to Buyer. However, Buyer shall pay all shipping charges, duties and taxes for products returned to Buyer in a country other than in India. Masibus highly recommends that prior to returning equipment for service work, our technical/Customer support department is contacted to provide trouble shooting assistance while the equipment is still installed.

EXCEPT FOR THE LIMITED WARRANTY STATED ABOVE, MASIBUS AUTOMATION AND INSTRUMENTATION PVT. LTD. DISCLAIMS ALL WARRANTIES OF ANY KIND WITH REGARD TO ITS PRODUCTS OR OTHER MATERIALS PROVIDED BY MASIBUS, INCLUDING WITHOUT LIMITATION ANY IMPLIED WARRANTY OR MERCHANTABILITY OR FITNESS FOR A PARTICULAR PURPOSE.

Masibus Automation and Instrumentation Pvt. Ltd. shall have no liability or responsibility to the original customer or any other party with respect to any liability, loss, or damage caused directly or indirectly by its product, material, or software sold or provided, replacement parts or units, or services provided, including but not limited to any interruption of service, excess charges resulting from mal-

functions of hardware or software, loss of business or anticipatory profits resulting from the use or operation of the Masibus product or software, whatsoever or howsoever caused. In no event shall Masibus be liable for any direct, indirect, special or consequential damages whether the claims are grounded in contract, tort (including negligence), or strict liability.

Masibus Automation and Instrumentation Pvt. Ltd. Offers extended warranty period beyond standard warranty. However, extended warranty can be ordered not later than the last month or year of standard warranty package.

Trademarks

Our product names or brand names mentioned in this manual are the trademarks or registered trademarks of Masibus Automation and Instrumentation (P) Ltd. (herein after referred to as masibus).

Adobe, Acrobat, and Postscript are either registered trademarks or of Adobe Systems Incorporated. All other product names mentioned in this user's manual are trademarks or registered trademarks of their respective companies.

Product Ordering Code

ORDERING CODE															
Model	Output 1		Output 2 [#]		Output 3 [#]		Output 4		Output 5 [#]		Power Supply		Antenna Cable Length		
MC-1-DE	X		X		X		X		X		X		X		
	0	None	0	None	0	None	0	None	0	None	U1	85-264V AC / 120-300V DC		1	15 Meter
	1	1 NTP	1	IRIG-B AM	1	IRIG-B AM	1	RS232	1	2 Event o/p ▲	U2	18-75V DC		2	30 Meter
	2	2 NTP	2	IRIG-B TTL	2	IRIG-B TTL	2	RS485	2	2 Event o/p ▲				3	50 Meter
										3					Alarm o/p
														S	Special

X - Specify from table
 *Contact factory for External Display Unit if required
 # IRIG B IEEE1344 option will work along with NTP o/p or Serial o/p only
 ▲Event o/p option will work along with Serial o/p only

2. Unpacking the MC-1-DE

Upon receipt, carefully examine the carton and its contents. If there is damage to the carton those results in damage to the unit, contact the carrier immediately. Retain the carton and packing materials in the event the carrier wishes to witness the shipping damage. Failing to report shipping damaging immediately may forfeit any claim against the carrier.

Remove the packing list from the envelope on the outside of the carton. Check the packing list .Against the contents to be sure all items have been received, including an instruction manual.

2.1 Packing List

2.1.1 Standard Items

Each GPS TIME SYNC UNIT MC-1-DE is shipped with the following:

- GPS TIME SYNC UNIT, Model MC-1-DE time source with Regular outputs.
- Antenna Cable RG6/RG8 as per specified cable length in Customer Order / quote.
- GPS Antenna and Antenna Clamp integrated
- 2 meters RG58 BNC Cable – Qty: 1
- 2 meters RJ45 Ethernet Cable – Qty: 1
- 2 meters RS-232 GPS Configuration Cable – Qty: 1
- Documents – User Manual and supporting Appendix manuals, Test Report, Test Certificates(On Customer Request only)
- CD for Masibus NTP Utility Software – Qty: 1

NOTE: Antenna Cable type (RG6 / RG8) and antenna cable length (15 meters / 30 meters / 50 meters / customized) is shipped only as per customer order. RG8 cable is provided if antenna cable length requirement is more than 50 meter. All Packaging list depends upon commercial terms and condition also as per order.

2.1.2 Optional Items

GPS TIME SYNC UNIT MC-1-DE model can also be shipped with below optional items only as per customer order.

- Unit Power Supply Cord
- Antenna Cable type and Antenna Cable length
- Lightening Arrestor
- In-Line Antenna Amplifier
- Antenna Splitter
- Antenna holding Mast (of specified length) and its holding clamps
- Antenna Cable GI Conduit

3. GPS Fundamentals

GPS TIME SYNC UNIT MC-1-DE device is a GPS/GNSS based receiver Unit which provides accurate time output with 1PPS signal. Satellite Navigation system is a system of satellites that provide autonomous geo-spatial positioning with global coverage. It allows small electronic receivers to determine their location (longitude, latitude, and altitude) to high precision (within a few meters) using time signals transmitted along a line of sight by radio from satellites. GNSS is a satellite navigation system that is used multiple navigation systems mainly GPS and GLONASS. GNSS also include satellite navigation systems of SBAS, QZSS, Galileo systems etc.

GPS satellite navigation system is maintained by United States of America since 1994 which consists of at-least 24 operational satellites out of 32 satellites in six orbital planes orbiting at an altitude of approximately 20,200 km. In typical GPS operation, four or more satellites must be visible to obtain an accurate result. Satellite-based navigation systems use a version of triangulation to locate the user, through calculations involving information from a number of satellites.

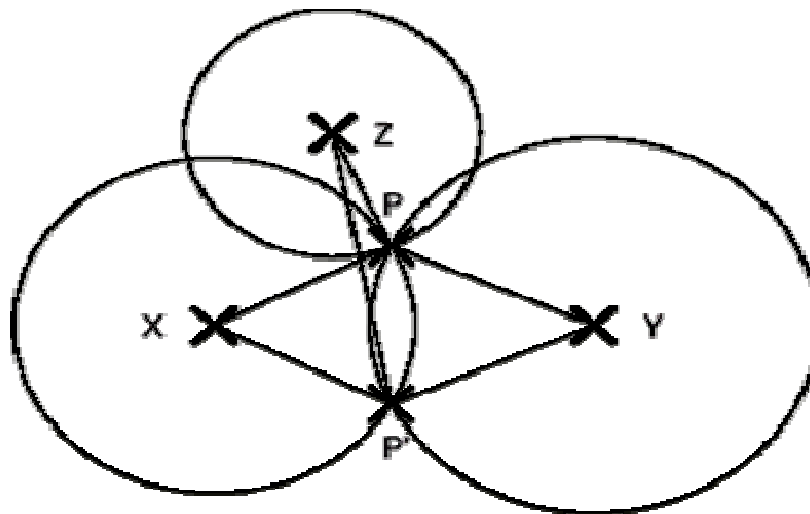

Figure 1 Basics of GPS

If one considers Figure 1 which shows a flat plane. X and Y are two known fixed points on the plane. P is an unknown point. If the distances PX and PY can be measured, then the position of point P can be calculated. Actually there is an ambiguity in that point P' would also fit the measurements. This can be resolved if the position of a third fixed point Z is known since PZ is different to P'Z. This can be summed up by saying that the unknown point P lies at the intersection of three circles based on the known points X, Y and Z.

When the plane becomes three dimensional spaces, the circles become spheres. The intersection of two sphere is a circle, and the intersection of three spheres is a pair of points analogous to the points P and P' of the flat plane case. As for the flat plane case a measurement from an extra fixed point is required to absolutely resolve the ambiguity, although in many cases the ambiguous point would be below the surface of the world. Thus to achieve the objective, GPS must provide accurate measurement of distance from the unknown location of the receiver to 4 known points.

GLONASS based satellite navigation system is maintained by Russia, a fully functional navigation constellation in 1995. After the collapse of the Soviet Union, it fell into disrepair, leading to gaps in coverage and only partial availability. It was recovered and fully restored in 2011. It provides an alternative to Global Positioning System (GPS) and is the second alternative navigational system in operation with global coverage and of comparable precision.

A fully operational GLONASS constellation consists of 24 satellites, with 21 used for transmitting signals and three for in-orbit spares, deployed in three orbital planes. The three orbital planes' ascending nodes are separated by 120° with each plane containing eight equally spaced satellites. The orbits are roughly circular, with an inclination of about 64.8°, and orbit the Earth at an altitude of 19,100 km, which yields an orbital period of approximately 11 hours, 15 minutes. The overall arrangement is such that, if the constellation is fully populated, a minimum of 5 satellites are in view from any given point at any given time. This guarantees for continuous and global navigation for users world-wide.

A characteristic of the GLONASS constellation is that any given satellite only passes over the exact same spot on the Earth every eighth sidereal day (1 sidereal day = 23 hours, 56 minutes, 4.0916 seconds). However, as each orbit plane contains eight satellites, a satellite will pass the same place every sidereal day. For comparison, each GPS satellite passes over the same spot once every sidereal day. So opposed to the GPS the ground-track of the GLONASS satellites do not repeat after one day. This avoids the resonance effects which makes station keeping of GPS satellites difficult and expensive.

In GPS navigation system, all satellites operates at same frequency at 1.57542 GHz (as L1 signal) and 1.2276 GHz (as L2 signal) using CDMA technique whereas GLONASS navigation system, all satellites operate on different frequencies using originally a 25-channel frequency FDMA technique spanning from 1602.5625 MHz to 1615.5 MHz, known as the L1 band.

As GNSS uses navigation satellite system of GPS, GLONASS and other available systems in space, GNSS receivers can easily observe 10 to 12 satellites at a time. As more number of satellites are visible, more accuracy in receivers output signals are achieved.

Each visible satellite broadcast two types of information in its message format i.e. Almanac and Ephemeris. Almanac data is coarse orbital parameters for all visible satellites. Each visible satellite broadcasts Almanac data for all visible satellites. This Almanac data is not very precise and is considered valid for up to several months. Ephemeris data by comparison is very precise orbital and clock correction for each visible satellite and is necessary for precise positioning. Each visible satellite broadcasts only its own Ephemeris data. The ephemeris is updated every 2 hours and is usually valid for 4 hours.

4. MC-1-DE Specification

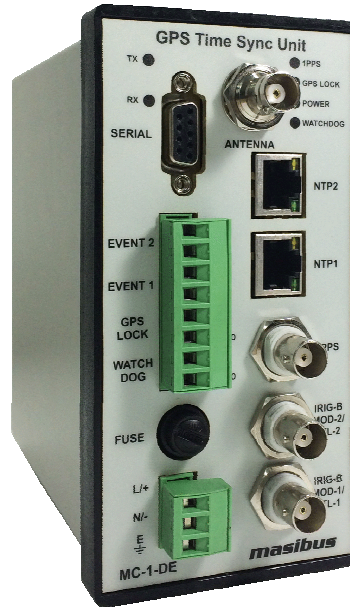

RECEIVER CHARACTERISTICS

Timing Accuracy

< 15 ns with GPS Receiver (Receiver is locked on fixed position)

Positioning Accuracy

<10m SEP (with Selective Availability [SA] Disabled).

Receiver Input

1575.42 MHz L1 C/A Code.

Tracking

12 parallel channels.

Acquisition Time

Hot Start : <5 s

Warm Start: <38 s

Cold Start : < 45 s

Memory Backup

Internal 17 mAh cell, Sufficient for 2 weeks of backup time
It requires 72 hours run for full charging.

Antenna

Active L1 GPS, 30 dB Gain

Cable: RG 6 / RG 8 (Optional coaxial cable)

	<p>Maximum Length: 100 meters (Up-to 400 meters using additional line amplifier) Coverage: 360 Degree Ingress Protection: IP20</p>
<p>OUTPUTS</p>	<p>Pulse</p> <p>1 PPS Accuracy: <150 ns Accuracy with GPS locked Output: TTL Output (Impedance 250 Ω) Pulse Width: 200 (200 mS High & 800 mS Low signal) Interface: BNC Female connector (Front Panel)</p> <p>Serial</p> <p>COM1 Protocol: NGTS/ T-format/NMEA Port Settings: 4800/9600/19200/38400/57600/19200, Programmable baud rate ,stop bit, parity bit and message format Output: Isolated RS232/RS485** (Factory Configurable) Interface: DB9 Female Connectors (Front Panel)</p>
<p>OUTPUTS</p>	<p>Alarms</p> <p>Two Isolated Dry Contacts to 230 VAC / 24VDC, 10 A:</p> <ol style="list-style-type: none"> 1. GPS Lock 2. Watchdog <p>IRIGB-TTL - DC Level Shift (DCLS)</p> <p>Format: IRIG-B(007) or IEEE 1344 (Field set) Output: TTL into 50 Ω Interface: BNC Female connector (Front Panel)</p> <p>IRIGB- Amplitude Modulated</p> <p>Format: IRIG-B(127) or IEEE 1344/C37.118-2005 (field set) Signal: 1 KHz AM Signal Modulation Ratio: 3:1 Output: 3.3Vp-p to 10Vp-p, into 100Ω Interface: BNC Female connector (Front Panel)</p> <p>Ethernet Output</p> <p>Time Synchronization protocols: NTP/SNTP Server NTP: Network Time Protocol (Version 3) RFC: RFC- 1119, RFC- 1305 SNTP: Simple Network Time Protocol (Version 3)</p> <p>RFC: RFC- 1361 Internet protocol: IPv4</p>

	<p>Mode: Server Time format: UTC Network Interface: 10/100 Mbps Interface: RJ-45 Connector (Front Panel)</p> <p>Additional Event Outputs</p> <p>Two independent configurable Event outputs Configuration: Individual configurable time period and pulse ON time through Serial Terminal Time Period: 1 to 86400 seconds (24 Hr.) max ON Time: min. 50 milliseconds and max 50% of period time set for particular event Event contact capacity: 350 VDC, 120mA maximum Interface: 4-Way Terminal Strip (Front Panel)</p>
<p>INTERFACE</p>	<p>Status LED</p> <p>Power : Red 1 PPS : Red Watchdog : Red GPS Locked : Green(GPS LOCK) TX : Red (Available only when serial output is available) RX : Red (Available only when serial output is available)</p> <p>Programming</p> <p>Using HyperTerminal in a local PC via serial terminal.</p> <p>Programmable parameters: Global Time zone correction Serial data format selection (NGTS or T-FORMAT or NMEA) Password Protection</p> <p>Network Settings: IP address, Subnet mask, Gateway and SNMP Manager IP addresses configurable through Telnet remote login. All network configurations are password protected.</p>
<p>POWER SUPPLY</p>	<p>AC: 85 to 264 V, 47-440 Hz DC: 125-300 V Power Consumption: <10W Typical (40W Max) Compliance :EN55011(CISPR11), EN55022 (CISPR22) Class B</p>
<p>OPTIONAL POWER SUPPLY</p>	<p>DC: 18 – 75 V Power Consumption: 10W Max</p>
<p>PHYSICAL DIMENSIONS</p>	<p>Width: 143mm Depth: 140 mm Height: 72mm Weight: 0.9 Kg(Approx)</p>

ENVIRONMENT	Temperature Operating: 0° C to +55° C Storage: -20° C to +80° C Humidity 20 - 90% (Non-condensing)
EXTRA MODULES (OPTIONAL)	RS232-to-RS485 Converter LINE AMPLIFIER, SURGE ARRESTOR Time Distribution Rack (TDR-4) Time Signal Repeater (TSR-4) Day Display Unit (DDU-XX) Netser (NGTS to NTP Converter)
Isolation (With-standing voltage)	Between primary terminals* and secondary terminals**: At least 1500 V AC for 1 minute Between primary terminals* and grounding terminal: At least 1500 V AC for 1 minute Between grounding terminal and secondary terminals**: At least 1500 V AC for 1 minute Between secondary terminals**: At least 500 V AC for 1 minute * Primary terminals indicate power terminals and relay output terminals. ** Secondary terminals indicate Output Ports. Insulation resistance: 20MΩ or more at 500 V DC between power terminals and grounding terminal.

5. Unit Front Panel Description

This section provides description of Din Rail GPS MC-1-DE unit front panel user applicable interface.

5.1 GPS TIME SYNC UNIT MC-1-DE Front Panel

Below image shows GPS TIME SYNC UNIT MC-1-DE model front panel. The front panel is equipped 6 LED status indicators and various outputs of GPS Time Sync Unit MC-1-DE device is provided at Front panel of unit

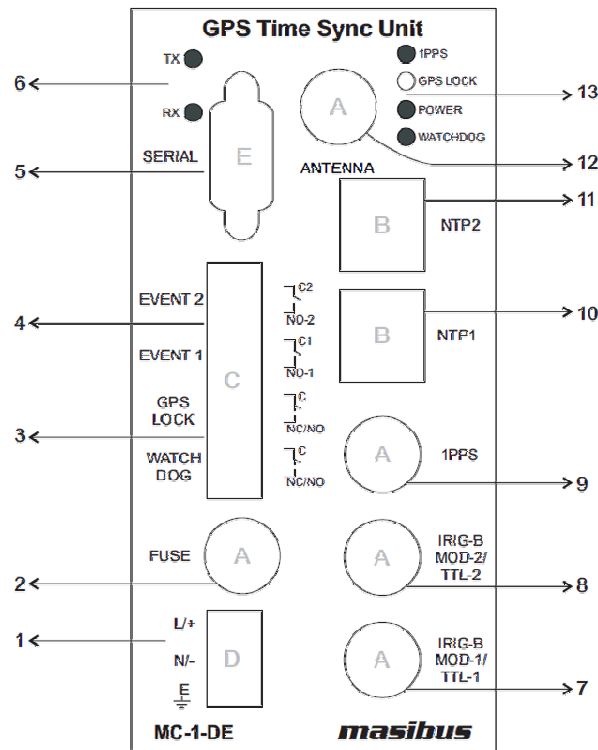

Figure 2 GPS Time Sync Unit Model MC-1-DE Front Panel

1. Power Input :

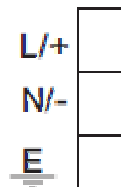

Figure 3 Power Supply terminals

2. **Fuse Connector :**



Figure 4 Fuse

GPS TIME SYNC UNIT MC-1-DE provide fuse of 3.15 A.

3. **Relay Output :**

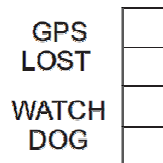

Figure 5 Alarm Relay Terminals

GPS TIME SYNC UNIT MC-1-DE provide two relay outputs for Watchdog and GPS LOST alarm through 4 pin female connector. Factory set Relay contact provided on Front panel connector are C-NO terminals.

4. **Event Output :**

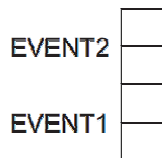

Figure 6 Additional event Terminals

GPS TIME SYNC UNIT MC-1-DE has the capability to provide two event outputs .The single event output provides pulse at configured event interval with pre-configured pulse width. This pulse outputs are Opto - MOS output (optically coupled solid state Relay output) provided through 4 pin female connector

5. **Serial Output :**

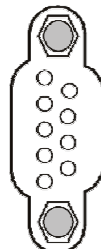

Figure 7 Serial Output Terminal

Serial terminal on Front panel is RS-232/RS-485 electrical standard DB-9 female connector as shown in figure 7.GPS TIME SYNC UNIT MC-1-DE provides serial time frame T-format / NGTS/ NMEA format on its terminal and can also be used for GPS TIME SYNC UNIT MC-1-DE configuration. This

terminal connection will be as per RS-232 electrical standard or RS-485 electrical standard as per specified during unit order. If nothing specified, the factory set settings of Serial terminal is as per RS-232 electrical standard output.

If Configuration of serial terminal is as per RS-232 standard, cross cable (having connection on Pin2, 3 and Pin5) can be used for configuration and to provide serial time frame to other peripherals. If Configuration of COM1 terminal is as per RS-485 standard, Pin 7 of DB-9 connector will act as D+ line and Pin 8 will be D- line.

6. **LED status for TX/RX**

This LED illumination is RED color and it indicates transmission and reception through serial terminal. Available only when serial output is available.

7. **IRIG – B1 Output**

GPS TIME SYNC UNIT MC-1-DE provides IRIG-B TTL and IRIG-B AM output through BNC connector on Front panel of unit as shown in Figure 8. IRIG – B TTL / AM can be Factory Selectable.



Figure 8 IRIG B Output Terminal

8. **IRIG – B2 Output**

GPS TIME SYNC UNIT MC-1-DE provides IRIG-B TTL and IRIG-B AM output through BNC connector on Front panel of unit as shown in Figure 9. IRIG – B TTL / AM can be Factory Selectable.



Figure 9 IRIG B Output Terminal

9. **1PPS Output**



Figure 10 1PPS Output Terminal

GPS TIME SYNC UNIT MC-1-DE provides 1PPS output at TTL signal level through BNC connector on front panel of unit as shown in Figure 10.

10. NTP1

GPS TIME SYNC UNIT MC-1-DE is equipped with 10/100 Mbps Ethernet output for NTP, SNMP and Telnet communication as shown in figure 11.



Figure 11 NTP1 Output Terminal

11. NTP2

GPS TIME SYNC UNIT MC-1-DE is equipped with 10/100 Mbps Ethernet output for NTP, SNMP and Telnet communication as shown in figure 12.



Figure 12 NTP2 Output Terminal

12. Antenna**ANTENNA**

Figure 13 Antenna Output Terminal

GPS TIME SYNC UNIT MC-1-DE device have a BNC female connector at its Front panel for connecting GPS antenna as shown in figure 13. This connector provides 5 VDC (4.7V DC to 5.2V DC) supply to antenna. Refer Antenna Installation section 6 for connecting GPS Antenna.

13. LED status Indicators: There are total 4 LED indicators including power led indication and three other status indicators.

- **POWER:** This LED illumination is RED color. This LED indicates the presence of power to unit.
- **1PPS:** This LED indicates the presence of 1PPS signal from GPS receiver module. It blinks at every one second. The illumination is of RED color.
- **WATCHDOG:** This LED illumination is RED color. This LED is ON when the unit becomes unhealthy due to GPS receiver module failure or internal failure.
- **GPS LOCKED:** This LED illuminates GREEN color if the GPS satellites signals are available and GPS is LOCKED, and stay off if no GPS satellites are available.

6. GPS TIME SYNC UNIT MC-1-DE Installation

Before beginning with unit installation, please follow important safety statements for avoiding installation practices causing malfunctioning of the device as mentioned below.



It is recommended to get the installation of this product to be done by authorized service personnel of the manufacturing company or by the trained and qualified operator in co-ordination with authorized service personnel of the manufacturer company.

Installation of the equipment is to be complied in accordance with local and national electrical codes.



This equipment is sensitive to Electrostatic Discharge (ESD). Observe all ESD safeguards while using this equipment.



This equipment can be damaged if incorrect power source voltage is applied.

This equipment can be damaged if power source is applied with incorrect polarity on its respective terminal.

Never plug unit power supply connector or power supply cables in terminal while main power source is ON.



This equipment should be always used with earth grounded. Never defeat the ground connector or operate the equipment in the absence of suitable earth ground connection.



Never work on open unit when power of unit is ON.

	<p>Unit is equipped with internal fuse. If it is blown Up or blowing again on its replacement, it is highly probable that either power source is incorrect or power source connection is improper.</p> <p>Internal fuse should be only replaced with same fuse type and same fuse rating as supplied from manufacturer factory. Replacement of Fuse should be done in unit Power OFF condition only.</p>
---	--

6.1 GPS Antenna and Cable Information

GPS TIME SYNC UNIT MC-1-DE comes complete with the necessary hardware to be able to receive GPS signals: 50-feet of RG-6 cable and a GPS antenna. The antenna cable is connected between the female N connector on the antenna and the female BNC connector at the Front panel of the Unit.

This section should help you with installing the GPS antenna and antenna cable(s) and connecting them to the model GPS TIME SYNC UNIT MC-1-DE. It should also be a source of information if you should need to trouble shoot the antenna cable system. These Unit achieve their accuracy. By comparing and adjusting the internal clock signal to the incoming GPS signal.

6.1.1 Terminal connection for Wall/Rack/Table Top Mount Enclosure

Refer steps for installation of GPS antenna and antenna cable as described below.

Selecting a GPS Antenna Site Outdoors

Select a site or antenna mounting position that...

- check the highest point available.
- Offers a full 360° view horizontally, to within 10° vertically of the horizon
- Is higher than neighboring buildings/obstructions
- Is protected from strong radio frequency (RF) and microwave transmissions
- Is set away from RF-reflective surfaces that cause multipath interference
- Is set 3 ft. (1 m) away from other GPS antennas

Avoid...

- Mounting the antenna between tall buildings or next to walls and equipment
- Cable type and cable length which runs from the antenna to the receiver that exceed the Specified length.
- Patching multiple cables together to make a single cable run
- Running the cable through bulkheads and alongside high-energy cables
- Crimping or damaging the cable

Blocked signals and multipath cancellation may significantly increase GPS signals acquisition time. Multipath Cancellation is caused by reflected signals that reach the antenna out of phase with the direct signal due to vertical reflective objects positioned to the side and above the antenna. To solve these problems, user must mount the antenna at least 1 meter away from and above the reflecting surface.

To properly receive GPS signals, the GPS antenna needs to be mounted clear of buildings as surrounding elements or heighted obstacles may block the GPS signals transmission done with the satellites. For complete antenna signals coverage, the antenna needs to have a clear view of the sky

and if the antenna is mounted in a less favorable location, it may work however GPS antenna signals reception capability may be somewhat limited/deteriorated during certain hours of the day.

6.1.2 Terminal connection for Wall/Din Rail/Panel Mount Enclosure

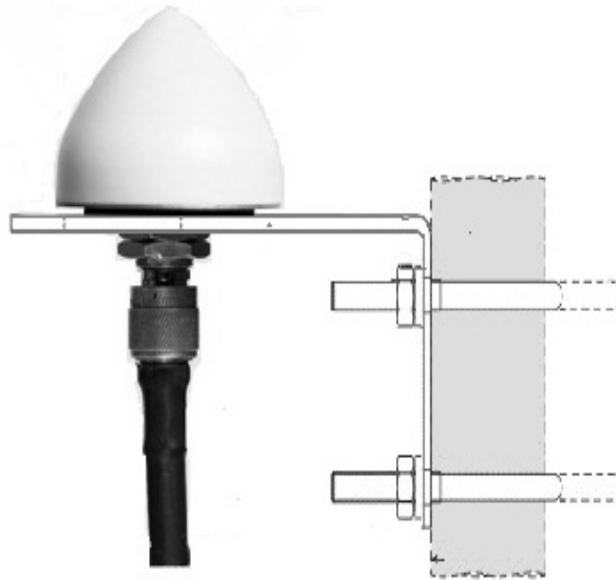

Figure 14 Antenna Mounting

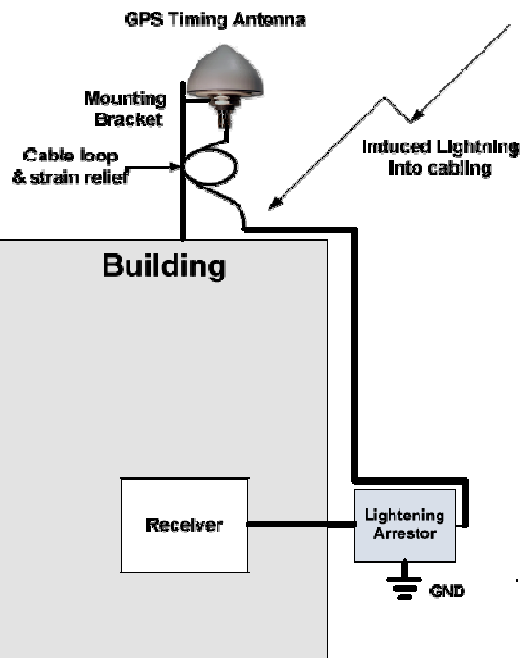

Figure 15 Antenna Mounting with Lightning Arrestor

Mount the GPS antenna on an antenna mast (recommended) or on the peak of a building. The GPS antenna kit (P/N no.: m-MK-AMC-40-1) includes special mounting brackets. For the mast, use 1-inch (2.54-cm) diameter water pipe which is rigid enough to withstand high speed winds without flexing.

The steps needed to assemble the kit are as follows (as per given figure):

1. Clamp the GPS antenna on the mounting bracket with a retaining nut.
2. Attach the mounting bracket to the pole (P/N: m-AR-01-01) using two guillotine-style U bolts and four hex nuts.
3. Connect the Type N male connector (antenna cable) to the antenna connector.
4. To ensure a trouble free installation the strain must be taken off the Cable by looping the cable.



- Use GPS antenna cable supplied from factory or as per recommended in manual. If antenna cable other than recommended is to be used, contact Masibus Customer Service representative.
- Do not cut the antenna cable to shorter its length. Instead, bundle the excess cable to shorten antenna cable length.
- The model MC-1-DE requires a 5 Volt-compatible antenna. Antennas not rated for 5 V will be damaged.
- Use a splitter to connect a single GPS antenna to multiple GPS TIME SYNC UNIT MC-1-DE units. Avoid using BNC "T" connectors.

GPS related Accessories

The following options/accessories can be ordered:

1. Protect against lightning and field-induced electrical surges.
2. Connect multiple GPS TIME SYNC UNIT MC-1-DE receivers to a single antenna.
3. Extend the range of the GPS antenna cable.

1. Lightning Arrestor

Lightning may damage GPS system components and receiving equipment, even without a direct hit, resulting in costly repairs and critical interruption of service. The lightning arrestor is designed to work in conjunction with a low-resistance, low-inductance ground to protect your GPS receiver and elements of the antenna system from lightning discharges and field-induced electrical surges. In-line lightning arrestors are mounted between the antenna and the point where the cable enters the building and require no additional power or wiring except the ground lead.

2. Antenna Splitter

An antenna splitter may be used to drive multiple GPS receivers using a single antenna. With built-in amplification to overcome splitter losses, the Active Splitters may be conveniently cascaded without adding separate amplifiers and bias-tees between splitters. Power is conveniently obtained from the GPS receiver(s) connected to the amplifier, eliminating the need for a separate dc power supply and wiring.

3. In-Line Antenna Amplifier

In-line amplifiers overcome signal attenuation in by amplifying the GPS signal. Use the in-line amplifier for cable runs of 100 to 200 meter. Please contact a masibus Sales Representative for information on how to extend the distance from the antenna to the receiver.

6.1.3 Verifying Antenna and Cable Operation



Please ensure that while doing below mentioned procedure for checking antenna voltage/current while unit is in POWER ON condition, do not **short** the antenna supply +5 Vdc and GND, in any case, failure of which will damage the unit internal electrical supply.



This equipment is sensitive to Electrostatic Discharge (ESD). Observe all ESD safeguards while using this equipment. Otherwise, there is danger that the unit may get damaged through ESD.

6.1.3.1 Checking the Antenna Voltage

GPS TIME SYNC UNIT MC-1-DE unit provides +5 Vdc to the GPS antenna through its Antenna connector on unit front panel, which is carried through the antenna cable. Nominal antenna current is 10 mA. Check the voltage at the antenna connector on the unit rear panel antenna connector. Without the +5Vdc supply on antenna connector of unit, the antenna and GPS TIME SYNC UNIT MC-1-DE will not synchronize with the GPS satellites signal and can generate an GPS UNLOCK alarm.

6.1.3.2 Power Supply Check

The Antenna Voltage test (mentioned above in section 6.1.3.1) actually tests the main power supply voltage for all models of GPS TIME SYNC UNIT MC-1-DE's. This voltage should be between 4.7 and 5.0 Vdc.

6.1.3.3 Checking the Antenna Resistance

Checking the internal resistance of the GPS antenna is not as useful as verifying the antenna current mentioned above in section 6.1.3.1. Antenna resistance measures several mega ohms with Multi-meter probes at one polarity and less so if you change the Multi-meter probe polarity.

6.1.4 Antenna Surge Suppressor

If GPS Surge Suppressor kit is available with purchase order, user should mount it in line with the antenna cable. Additional information on grounding GPS antennas, and grounding in general, are available from Masibus Customer Support division (Kit P/N :m-LA-01).

6.1.5 Technical Details on GPS Antennas and Cables

Antenna Cable

Length and Loss Considerations

Standard Antenna Cable

The standard antenna cable assembly included with GPS TIME SYNC UNIT MC-1-DE is constructed using a 15-meters (50-foot) length of RG-6 type low-loss coaxial cable, terminated with male Type N connector and BNC male connector. Optional lengths of RG-6 coax are separately available for longer runs; see Table 6.1, Cable Data and Accessory Information.

Effects of Cable Parameters

To receive GPS signals and properly operate the GPS Time Sync Unit, the type and length of the cable are important. Due to their effect on specific parameters described in the following paragraphs, any changes to the length and/or type of antenna cable should be made carefully. Damaged cables may also affect performance.

Cable Delay

The velocity factor and the physical length of the cable determine cable delay. User has to enter delay value according to antenna cable length.

For cable options, the delay is tabulated below. The formula for calculating cable delay is:

$$T = \lambda \frac{1}{CKv} + 1ns$$

Where:

T = Cable delay, in nanoseconds;

λ = Cable length, in meters;

C = Speed of light (3 _ 108 meters per second);

Kv = Nominal velocity of propagation (0.85).

One nanosecond is added to the calculated value to account for the length and velocity factor of the short connecting cable inside of the GPS Time Sync Unit.

Attenuation

Attenuation depends upon the cable length, and the loss per unit length. The total attenuation must be limited to 30 dB (maximum) at the GPS L1 frequency of 1575.42 MHz

DC Resistance

The cross-sectional area and length of the conductors in the cable determine the dc resistance. Since power to the RF preamplifier in the antenna is supplied via the antenna cable, excessive dc resistance will degrade performance. Because of the above factors, changes to the length and/or type of antenna cable should be made carefully. Damaged cables may also affect performance.

Available Antenna Cables and Accessories for Longer Runs

masibus offers longer antenna cables for use with models GPS Time Sync Unit when the standard 15 meters (50-foot) cable is inadequate. RG-6 cable runs up to 50 meter, RG-8 cable is available for 100 meters (328 foot) **without the** in-line preamplifier. **masibus** offers in-line amplifier, (P/N: m-LA-01) for long antenna cable requirement up to 200 meters (656 foot).

Description	Delay, ns	Signal Level, dB
15-m (50-ft) cable, RG-6	60 ns	5dB
30-m (100-ft) cable, RG-6	120 ns	9dB
50-m (164-ft) cable, RG-6	200 ns	15dB
100-m (328-ft) cable, RG-8	393 ns	17dB

Table 1 Antenna Mounting

Connection to Antenna

The male Type N connector on one end of the antenna cable mates with the female Type N connector on the antenna.

Connection to GPS Time Sync Unit

The male Type BNC connector on the opposite end of the antenna cable connects to the female Type BNC connector on the front panel of the GPS Time Sync Unit.

6.2 Unit Installation

After GPS Antenna installation is complete, GPS TIME SYNC UNIT MC-1-DE unit can be installed as per below procedures.

- It is necessary to provide correct power supply to unit as per specified order or as per power supply specification mentioned at the unit's Front panel.
- Ensure that the power supply polarity connections are done as per mentioned Label on specific power supply connector terminal on rear panel.
- It is recommended to not connect the NTP outputs in installation site Ethernet network till proper network settings are done in unit.
- After the power supply is connected properly, Refer section 7.3 for the Unit Power ON status.
- At startup, the clock of unit in Unlock conditions may not be correct if the unit was in Power OFF condition for long duration. Refer section 7.1 and 7.2.
- It is necessary to change the Ethernet addresses of unit NTP output ports individually (connecting NTP port directly with PC using Ethernet cable) before using GPS as NTP server.
- After unit settings and configuration is done, user should provide power restart to unit.
- After unit Power ON, unit should be kept in LOCK condition for warm up duration.
- Once unit is Power ON, it is necessary to keep the unit in LOCK condition for minimum 1 hour for precise and accurate timing outputs during unit LOCK and Holdover conditions.

6.3 Mechanical Dimensions

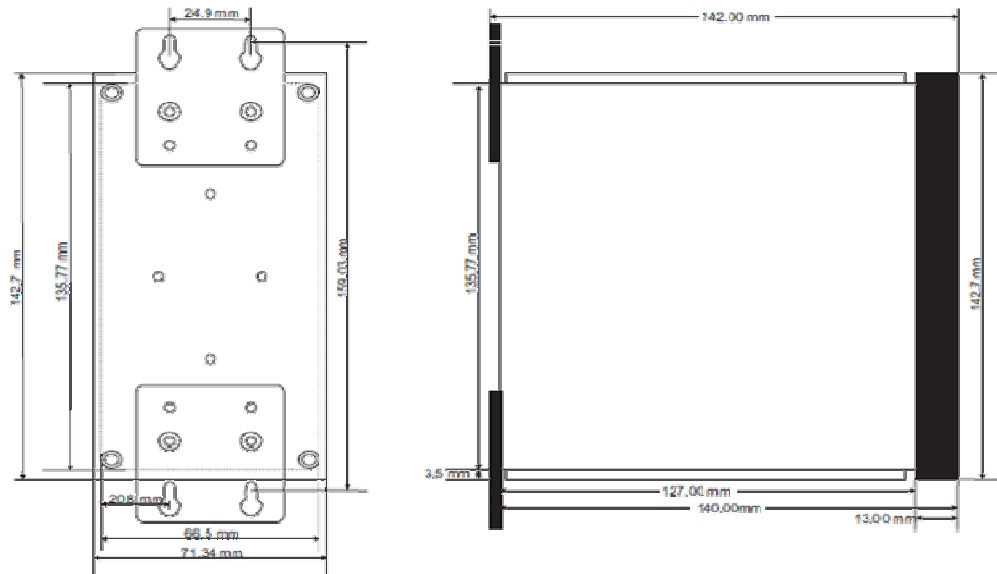

Figure 16 Wall Mount Mechanical Dimension Layout

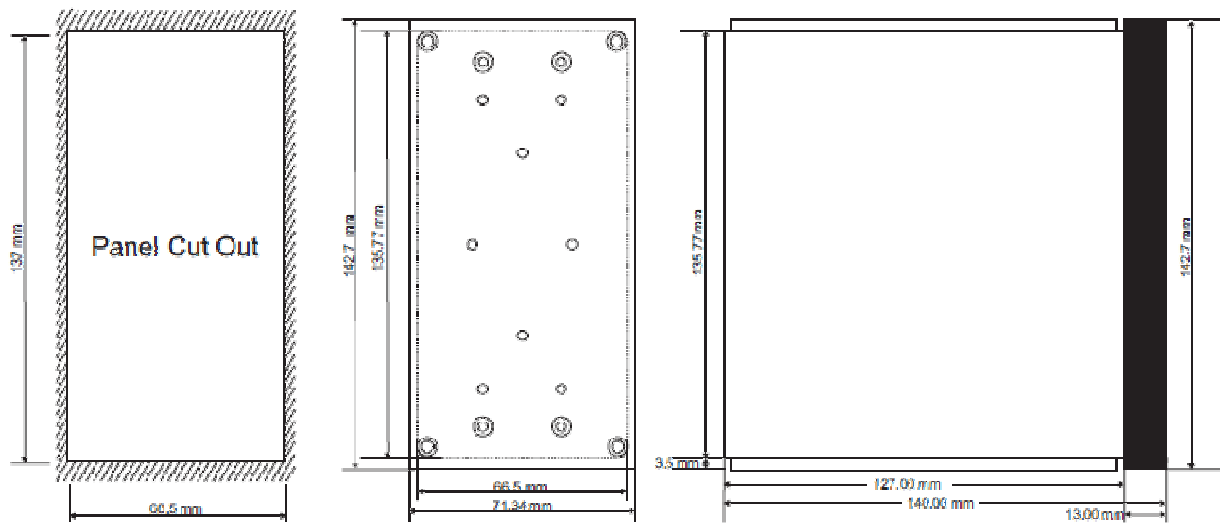

Figure 17 Panel Mount Mechanical Dimension Layout

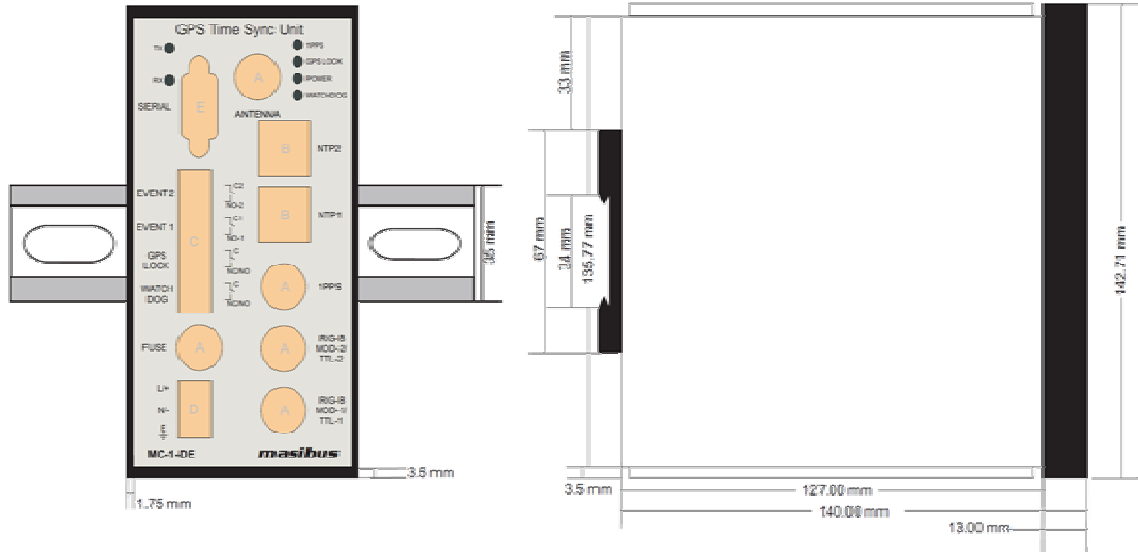

Figure 18 Din Rail Mount Mechanical Dimension Layout

6.4 Wiring Diagram

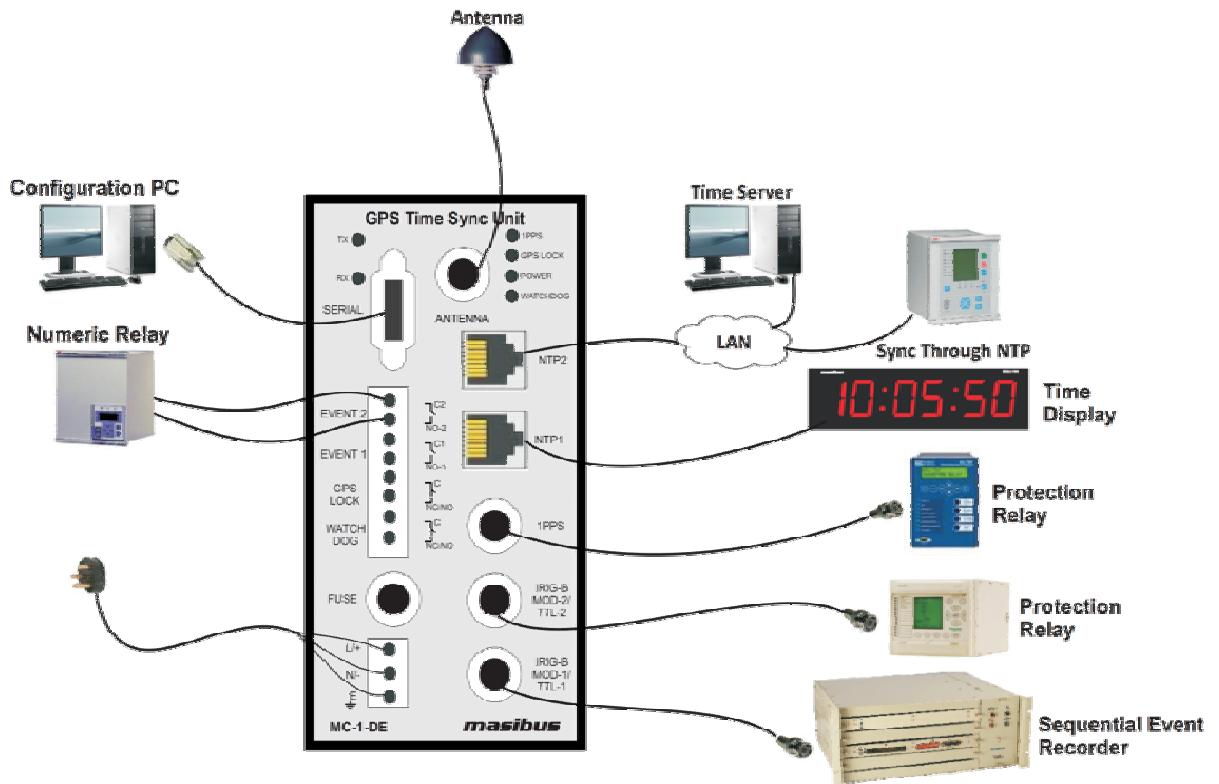

Figure 19 Wiring Diagram of GPS Time Sync Unit

7. GPS TIME SYNC UNIT MC-1-DE Power ON

7.1 Receiver Boot-up mode

When GPS TIME SYNC UNIT MC-1-DE unit is power up, the time of unit depends on the GPS receiver RTC data. At every Power ON, unit is in UNLOCK mode initially. If GPS antenna is connected after Power ON or was already connected while powering up the unit, the time to getting unit LOCK depends on the duration for which the unit was in Power OFF condition. Also, if the unit was in UNLOCK condition during the normal operation of unit, the time taken by unit to get LOCK after antenna is connected depends on the duration for which unit was in UNLOCK condition.

Refer below explanation for time taken by unit to get LOCK after Power off or UNLOCK condition.

For a receiver to obtain a position fix, it must download the almanac and ephemeris information from the satellite through a satellite frame. The receiver must download almanac and ephemeris information to achieve a position fix. Depending on the parameters such as valid almanac, ephemeris data of previous visible satellites, last position of receiver and time stored, the boot process (Cold start / Warm start / Hot start) mode is determined.

Cold start: If the GPS receiver does not have any initial data regarding current almanac, ephemeris data (case when backup battery is discharged) or it has invalid data for almanac and ephemeris information, on boot up the receiver will enter in Cold start mode. In order to get current almanac data, GPS receiver should receive at least one satellite frame. Typically, TTFF (Time to First Fix) for position in Cold start is less than < 45 seconds because each GPS receiver may take few seconds time to get initialized on boot up and as each satellite frame takes 30 seconds to transmit single frame.

Since each satellite transmits total 25 frames as satellite complete broadcast message, complete almanac data is transmitted by satellite in 12.5 minutes. So, in order to have very highly accurate position and time data, to reach 90% confidence level after acquiring complete almanac data from each satellite, Cold start for TTFF (Time to First Fix) can be < 15 minutes, it will acquire almanac and ephemeris data for visible satellites and thereafter receiver will enter in its normal operation mode. In this case, it is necessary that antenna should be located in open environment having no immediate obstacles.

If the device is moved to very far location in hundreds of kilometers from its last operation position and system is made ON, then receiver will try to identify visible satellites data and compare it with previously stored almanac data. If this does not match, receiver will start as in Cold start mode.

Warm or Normal start: In the warm start mode, when the receiver boots and if the information of current almanac satellite data, time which receiver knows is within 20 seconds from the satellite time, receiver position to within 100 km, but do not have ephemeris information or ephemeris information may be invalid, the receiver enters Warm start mode. Typically, time required for position fix in Warm mode is less than 38 seconds as each satellite transmits its ephemeris data at every 30 seconds.

If the receiver does not have valid almanac data, it enters the Cold start mode.

Hot start: When receiver boots up, if the information/data of current almanac, position, current time is stored and are valid, receiver enter Hot start mode and provides accurate time within few tens of seconds.

7.2 Battery Backup RTC and GPS receiver RAM Configurations:

Backup batteries are used to keep the RAM and the Real-Time Clock (RTC) in the receiver running even after unit Power OFF to retain setup and status information, Time, Date, Last Calculated Receiver Position, Almanac and Ephemeris information along with receiver specific parameters allowing resumption of GPS operation automatically once unit mains power is restored. In this “Warm Start” scenario when the unit power is restored, the receiver scans the RTC to check how much duration has elapsed since power was removed, calculates which satellites should be visible using the previous stored almanac information and then proceeds to develop fix information providing data.

The battery is a maintenance-free rechargeable Manganese lithium type. A built-in battery charging circuit is used when the unit is powered on, eliminating the need for maintenance.

Battery Specification:

Manganese lithium, 3.6 volts, 17 mAh,
Memory Retention Time: 15 days (approx.)



It is recommended that if GPS TIME SYNC UNIT MC-1-DE unit was in Power off condition for the duration more than specified Memory retention time, user should allow to keep unit in Power ON condition for 72hours to charge the RTC backup battery to full level.

Non Volatile Memory Configuration:

The GPS Time Sync Unit maintains its all configuration parameters internally in non-volatile memory, even when the power is off.

7.3 Startup Operation

Before powering up GPS Time Sync Unit MC-1-DE Model device, user has to ensure that power supply connections are done properly. When power is applied, below is basic start up sequence of GPS Time Sync Unit MC-1-DE Device.

- While GPS is in Power off, all the outputs are disabled.
- As soon as Power is applied, GPS POWER LED in “Red” color on front panel illuminates.
- Few seconds after GPS unit is powered up, 1PPS LED will start flashing in RED color which indicates the Pulse per second output available.
- After some time all other outputs will become active.
- If unit was in Power OFF conditions for duration longer than required as per battery backup requirement (refer section 8.1 and 8.2), the time of GPS Time Sync Unit MC-1-DE device will get reset to **default time** (Time: 23:59:56 and Date: 21/8/99), in such case all outputs such as time on display, NTP, IRIG-B, serial time outputs, all event outputs will be not available. The time will only be corrected after GPS Time Sync Unit Unit gets in LOCK condition after GPS antenna is connected to device or correct time (manual time) is entered through telnet or serial configuration. Manual time setting is explained in the later stage of the manual as well as m05dom_Appendix E1_rev01.
- There are other 2 status LED's on front panel of GPS Time Sync Unit MC-1-DE device. When Power is applied to the device and If GPS Antenna is connected, after few minutes, GPS will get Lock and will be indicated by GREEN indication on GPS LOCKED LED. The time taken

- to get GPS lock will depend on start mode of GPS receiver whether GPS receiver is in Cold start or Warm Start or Hot start mode.
- GPS Time Sync Unit MC-1-DE device provides relay contacts on its terminal at Front panel of unit for GPS Lost and Watchdog output. Factory set configuration for relay contacts for all two mentioned outputs is C-NO terminal.
 - After time is available on serial terminal, watchdog relay contact gets energized after 5 to 6 seconds. Watchdog relay status indicates the healthy functionality of unit. If unit becomes unhealthy, the watchdog relay output will be off after few seconds and watchdog LED in front panel will be ON. It will maintain its output status till the unit regains its healthy status.
 - If GPS Time Sync Unit MC-1-DE is in LOCK condition, GPS LOCK relay will be in energized condition and GPS LOCK led on front panel will be ON.
 - Additional event outputs (optional) are ON as per respective event time configured. Factory setting of all additional event outputs (optional) are set as 60 seconds event time with 50 milliseconds event ON period.
 - Once unit is Power up, unit will start transmitting serial frame as selected in configuration or by default NMEA frame on serial terminal located at front panel of unit. NMEA output communication settings will be at 9600, 8, N, 1. NTP outputs will be at configured factory set factory IP address and will be active once NTP client request are received on particular NTP port. IRIG-TTL output will be at TTL voltage level i.e. 0(low level) and 5V(high level) and IRIG-AM (Amplitude Modulated) output will be available at 3.6Vpp

7.4 Basic Normal Run Mode Operation

- After unit is boot up completely all the outputs of unit i.e. event pulse outputs, IRIG, NTP and serial time outputs will be available as per unit clock.

8. Serial Communication and Configuration

GPS TIME SYNC UNIT MC-1-DE device has Serial terminal at Front panel of instrument which is female DB-9 connector operating on RS-232 electrical standards. This terminal can be used to configure GPS TIME SYNC UNIT MC-1-DE device parameters only when serial terminal of GPS TIME SYNC UNIT MC-1-DE device is connected to RS-232 terminal of computer using 9 pin CROSS Cable (refer below section for cable connections). The serial terminal also transmits serial based time signal (T-Format or NGTS or NMEA depending on device configuration) only when Model device is not in configuration mode.

NOTE: Serial terminal of Model device is also available as RS-485 electrical standards instead of RS-232 standards as an optional feature.

Configuration requires a standard 9-way D-type RS-232 cable and standard serial communication software in the PC, such as **HyperTerminal**.

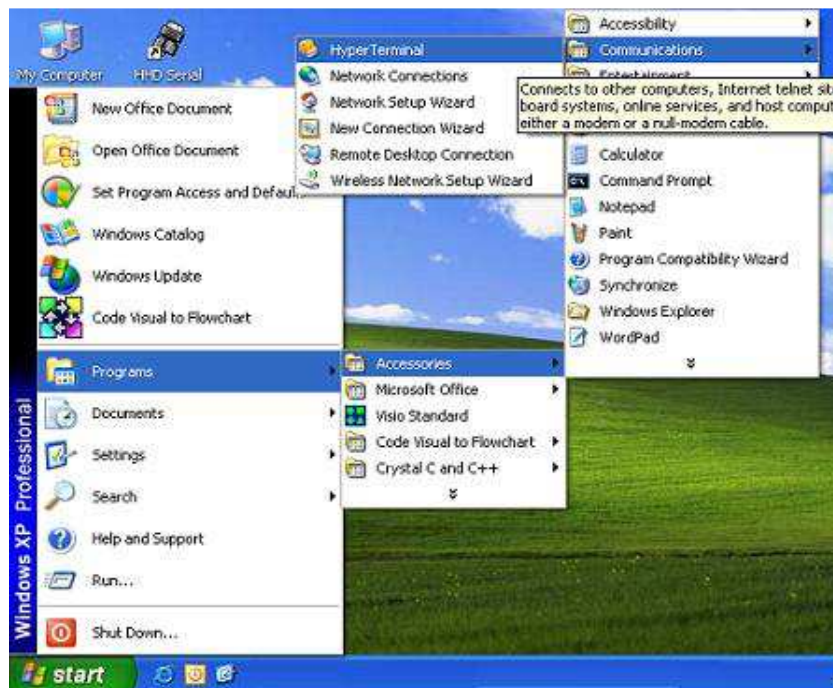

Figure 20 HyperTerminal

8.1 Serial Port Setup and Serial Cable Configuration

The cable requirement for GPS TIME SYNC UNIT MC-1-DE configuration is shown in figure 22. Connect one end of the cross cable to the serial terminal of GPS TIME SYNC UNIT **MC-1-DE** and other end to an available serial port on your local computer. (If there is no RS-232 terminal in user's computer, user can use USB-To-Serial convertor. Masibus do not provide USB-To-Serial convertor as part of accessories supplied with GPS TIME SYNC UNIT MC-1-DE device).

Note:- In case of RS485 Communication external Standard 485 to 232 Or 485 to USB converter will be required. And it will not be a part of this Product.

Open the **HyperTerminal** and start **new connection** on **COMX** of your PC. (X can be any available serial RS232 port number) as shown in below figure. User can enter any name in “NAME” option.

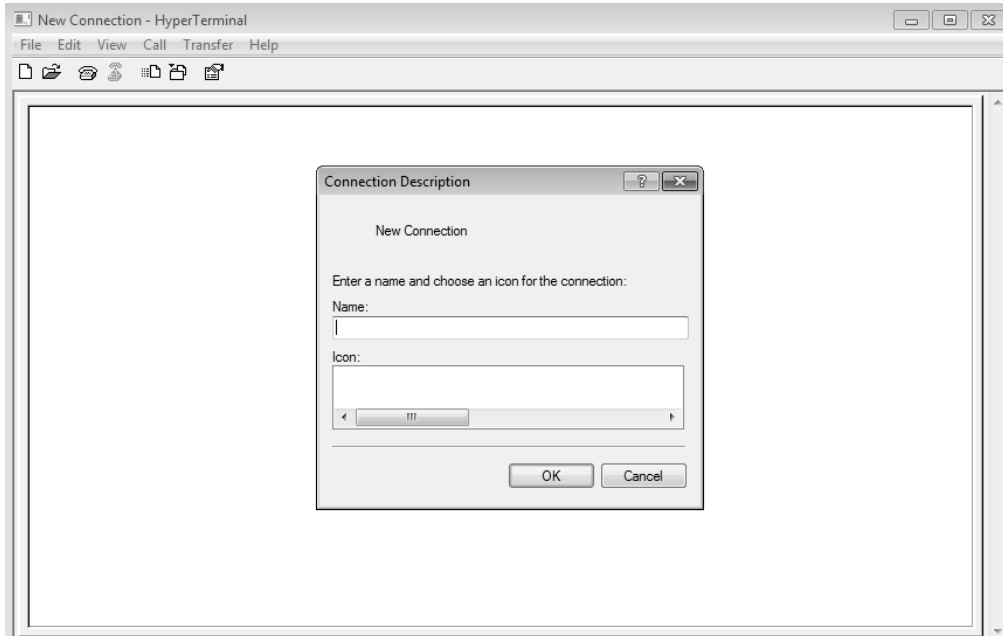

Figure 21 HyperTerminal new connections.

In using **HyperTerminal**, it is recommended to select **File\Properties\Settings** and set **Emulation to ANSI**, to avoid auto-detect making unwanted changes to the settings.

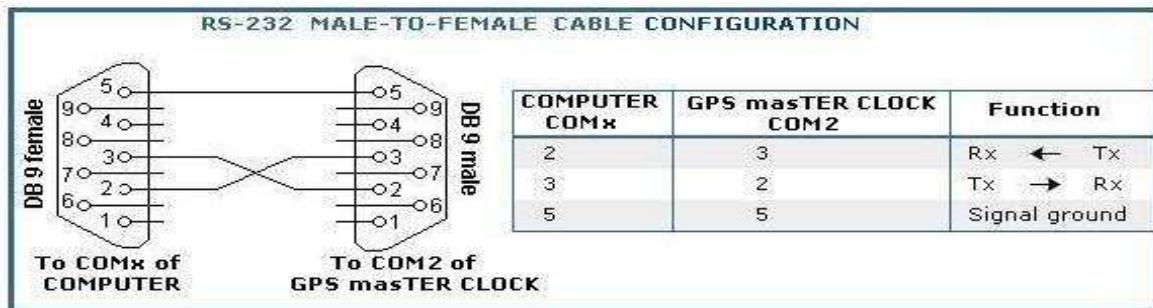

Figure 22 RS-232 Male to Female cable connection.

	<ul style="list-style-type: none"> • Cross cable connection as mentioned in above figure is necessary to communicate with serial terminal. • Ensure serial communication setting done in GPS TIME SYNC UNIT MC-1-DE unit and end device should be same for proper communication.
--	--

The port settings in **HyperTerminal** and the Serial port of GPS TIME SYNC UNIT **MC-1-DE** must match each other for fruitful communication. The factory set settings of Serial port of GPS TIME

SYNC UNIT **MC-1-DE** are set 9600(baud rate), 8 (data bits), N (Parity-None), 1 (stop bit). It is necessary that user have to select "NONE" option in "Hardware Flow Control" option while doing communication parameters settings in HyperTerminal. Refer "USER CONFIGURATIONS" section in manual.



Figure 23 Hyper Terminal new connection configuration.

After connection is setup successfully, user can see the time frames coming from unit on HyperTerminal. By factory set, GPS TIME SYNC UNIT MC-1-DE device is configured to provide NMEA output at 9600(baud rate), 8 (data bits), N (Parity None), 2 (stop bit) communication settings. NMEA output will be transmitted at every second with respect to GPS TIME SYNC UNIT MC-1-DE time.

NOTE:

- The unit will enter the configuration as soon as it will receive CONFIG command followed by an "Enter".
- Once the configuration mode is entered, the unit will stop sending time frames on serial terminal.
- If user doesn't enter any command up to 120 seconds, then it will come out of configuration mode with the message "**CONFIGURATION MODE HAS BEEN TIMEOUT**" and starts sending time frame.
- If user hits "Enter" key of PC keyboard without giving any command, unit will come out of configuration mode and the time frames will start getting transmitted from serial terminal again.
- In case of improper entry of command, following message will appear on the screen:

**INVALID COMMAND
ENTER COMMAND TO CONFIGURE PARAMETER
TO CONTINUE PRESS ENTER**

8.2 Configuration Commands

GPS TIME SYNC UNIT MC-1-DE serial terminal can be used for configuring communication parameters of serial port settings for serial terminal, output time string format (T-format / NGTS/ NMEA) on Serial terminal , time display format, general parameters settings, time zone offset, password, standard and additional event time outputs, antenna cable propagation delay, defaulting Ethernet port addresses.

All commands types are mentioned as subtitle name in below descriptions.

8.2.1 General Commands:

8.2.1.1 Command: CONFIG

This command lets the user to enter in the configuration mode. After giving command '**CONFIG**' and pressing **Enter** key, unit will stop the transmitting serial time output on serial port and unit will ask the user to enter the password on HyperTerminal, as shown below:

```
-----  
T:14:12:18:04:15:13:01:10  
T:14:12:18:04:15:13:02:10  
CONFIG
```

```
ENTER PASSWORD :  
-----
```

8.2.1.2 Message: ENTER PASSWORD

There are two passwords for GPS TIME SYNC UNIT MC-1-DE. One is user-defined password, which can be changed by the user through password configuration command and other is master password which cannot be configured or visualize in menu settings. User defined password factory set is '**MASIBUS**'. If user changes the user password by configuration command, user has to enter new password instead of factory set password.

If user changes the user password by configuration command, factory set password will change from '**MASIBUS**' to the new password entered. User has to remember if the new password is configured by user as there is no option to read the set password.

There is inbuilt factory Password which cannot be changed by user. Please contact Masibus Customer Service department if user forgets their own set password. Unit will enter the configuration mode if correct password is typed and then press Enter. If User enters correct password, below messages will be seen.

```
-----  
ENTER PASSWORD: *****  
  
PASSWORD OK  
ENTER COMMAND TO CONFIGURE PARAMETER.  
H FOR HELP MENU.  
L FOR PRESENT SETTINGS.  
-----
```

Only after user successfully entering configuration mode as show in above messages, user can now provide other commands for device configuration.

If the entered password is wrong, the following message will be displayed:

```
-----  
ENTER PASSWORD: ****
```

WRONG PASSWORD
 TO CONTINUE PRESS ENTER
 T:14:12:18:04:15:13:49:10

To re-enter into the configuration mode if wrong password is entered, again start by giving '**CONFIG**' command and enter correct password.

8.2.1.3 Command: L: LIST PRESENT CONFIGURATIONS

Description: This command lists all the general parameters with their current value or current configuration. Command type is listed in first column, parameter current value in third column and general meaning of the particular command in last column in the output of "L" command. On writing 'L' command, it will display the present settings of the parameters of **GPS TIME SYNC UNIT MC-1-DE** as shown below.

 H FOR HELP MENU.
 L FOR PRESENT SETTINGS.
 L

PRESENT SETTINGS

COMMAND	MODE NAME	VALUE(x)	MEANING
SBx	Baud Rate	96	9600 Baud Rate
SPx	Parity	0	Parity None
SSx	Stop Bit	1	1 Stop Bits
SUx	Time Format	2	LOCAL time
TC2x	Transmit Mode	1	NMEA Mode
I_1344	IRIGB_ IEEE_1344	D	DISABLED
IRIG	IRIGB_Time	L	LOCAL
Z	TIME ZONE	+00:00	
ET1	Addi. Event1	00000060	Seconds Mode
ET2	Addi. Event2	00000060	Seconds Mode
EW1	Event1 ON Time	00000050	m.Seconds Mode
EW2	Event2 ON Time	00000050	m.Seconds Mode
SPD	Propagation Delay	00000000	n.second Mode

 ENTER COMMAND TO CONFIGURE PARAMETER
 OR PRESS ENTER TO CONTINUE.

8.2.1.4 Command: H [HELP Command

Description: The 'H' command is a general HELP menu and will list all the commands to configure **GPS TIME SYNC UNIT MC-1-DE**. It lists all the possible values with their meaning of a particular command which are applicable and considered as valid command. Values other than specified in output of help command considered as Invalid value.

GPS TIME SYNC UNIT SYSTEM

Version No: 101

UART commands:

- SBxx : Set baud rate.
 - 24 : 2400 baud rate.
 - 48 : 4800 baud rate.
 - 96 : 9600 baud rate.
 - 19 : 19200 baud rate.
 - 38 : 38400 baud rate.
 - 57 : 57600 baud rate.
 - 11 : 115200 baud rate.
- SPx : Set parity bit.
 - 0 : parity bit set to none.
 - 1 : parity bit set to odd.
 - 2 : parity bit set to even.
- SSx : Set stop bit.
 - 1 : stop bit set to 1.
 - 2 : stop bit set to 2.
- SUx : Set UTC OR IST time.
 - 1 : UTC time.
 - 2 : LOCAL time.
- SPD(xxxxxx) : 1PPS Cable Delay Correction command(Propagation Delay).
 - : Range: 0 to 99999 ns.
 - : Default value: 0 ns.
 - : Resolution: 1 ns.
- TC2x : Set transmit mode.
 - 1 : NMEA mode.
 - 2 : t-format mode.
 - 3 : NGTS mode.
- P(password) : To change password.
- M(time&date) : Manual Time Setting Mode
 - : Enter command M(hh:mm:ss,dd/mm/yy)
- R : Reset the controller.
- D : Set to Default Setting.
- ETH0 : Set to Default Network Settings.
- ETx : To configure additional Events.
- EWx : To configure additional Events ON Time.
- Z : Set Timezone Setting.
- I_1344 : E = Enabled.
 - : D = Disabled.
- IRIG : U = UTC time.
 - : L = Local time.

ENTER COMMAND TO CONFIGURE PARAMETER
OR PRESS ENTER TO CONTINUE.

If the user presses the 'Enter' key before writing any command, unit will come out of configuration mode and operator has to enter 'CONFIG' and password again. Any pressing of 'Enter' instead of command will result in a jump out of the configuration mode.

8.2.2 Communication Commands:

	<ul style="list-style-type: none">• The existing serial communication channel will break if user changes any of the below serial communication settings through serial communication command.• User has to do re-login to again communicate with serial terminal as per explained procedure.
---	---

The communication commands change the parameters of serial communication port of the **GPS TIME SYNC UNIT MC-1-DE Model**. These include **SBxx**, **SPx** and **SSx**.

These commands change the configuration of Serial port of GPS TIME SYNC UNIT MC-1-DE while in configuration mode; hence the serial communication on serial terminal between the unit and HyperTerminal stops.

To reinitialize the serial communication, first **disconnect** the link and then enter into the **settings** of the HyperTerminal and set it same as the present setting of GPS TIME SYNC UNIT MC-1-DE. Again **connect** the link.

8.2.2.1 Command: SBxx [Baud Rate Command]

Applicable Options: SB24 / SB48 / SB96 / SB19/ SB38/ SB57/ SB11 (Please refer 'H' Command menu for applicable meanings of mentioned options)

1. Suppose that the desired baud rate is 4800, the command should be SB48 (See H: HELP). This will display following on the HyperTerminal:

ENTER COMMAND TO CONFIGURE PARAMETER
OR PRESS ENTER TO CONTINUE.
SB48

Now, the communication must have stopped.

2. Disconnect the link by a right click on Call\disconnect.



3. Enter the settings by following the path:

File\Properties\Connect To\Configure.

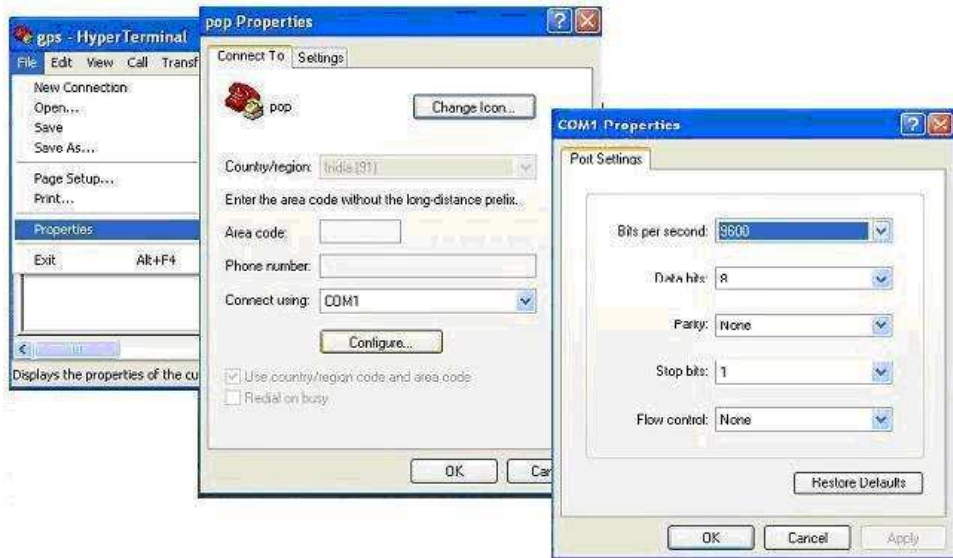

Figure 24 Hyper Terminal Property configuration.

4. Set the baud rate to 4800 and check for other parameters to be same as that of GPS TIME SYNC UNIT MC-1-DE
5. After setting the parameters, reconnect the link by right click on Call\Call.



6. Now press ESC and Enter keys.
7. Once the connection is reestablished, the time data will again be displayed on the HyperTerminal.

8.2.2.1 Command: SPx [Parity Command]

Applicable Options: SP0 / SP1 / SP2 (Please refer 'H' Command menu for applicable meanings of mentioned options)

The change of parity configuration can be done using this command. Different options for the parity settings are as below:

NOTE: It is necessary to change the value Parity, if user changes the parity of GPS TIME SYNC UNIT MC-1-DE serial terminal as per applicable value mentioned below:

- SP0:** No Parity
8 data bits
- SP1:** Odd Parity
8 data bits
- SP2:** Even Parity
8 data bits

Same as **SBxx** command, the communication stops as soon as you finish the command and press 'Enter' once. This is because the protocol settings at **GPS TIME SYNC UNIT MC-1-DE** and **Hyper-**

Terminal do not match. To correct this, follow the steps 2 and 3 of **SBxx** command. Now correct the parameter to match with desired/set ones.

After setting the parity in this setting window, follow the steps 5 and 6 of the **SBxx** command. The time data will again re-appear. You can check present settings using 'L' command.

8.2.2.3 Command: SSx [Stop Bit Command]

Applicable Options: SS1 / SS2 (Please refer 'H' Command menu for applicable meanings of mentioned options)

The number of stop bits in the serial communication can be set as 1 or 2 using this command. The options are simply two:

- SS1:** One stop bit
- SS2:** Two stop bits

The steps to follow are same as **SBxx** and **SPx** command.

8.2.3 Time Zone Offset Command:

Command: Z

This command is to enter the time offset of any particular region/country with reference to the UTC. Every country local time works at some time offset with respect to UTC. Time offset can be positive or negative w.r.t. UTC. The table of the time zone offset can be found from Internet.

Time zone offset value should be between time ranges of **-12:45 to +12:45**.
Time offset value apart from above range will be considered as INVALID command.



The time zone will put its effect on the IRIG-B signal, when the IRIG-B of the unit is configured for Local time as well as it will affect the time on unit, NGTS and T-frame only if the unit is set in the LOCAL TIME DISPLAY mode, using the SUx command as explained further.

Example:

Z

ENTER THE TIME-ZONE OFFSET ADDED WITH THE DAY-LIGHT SAVING TIME, IF APPLICABLE.

FORMAT: (+/-)(HH):(MM)

ENTER NOW:

-02:00

COMMAND COMPLETE

ENTER COMMAND TO CONFIGURE PARAMETER.

TO CONTINUE PRESS ENTER

8.2.4 Serial Time Frame Command:

Command: TC2x [Serial frame Command]

Applicable Options: TC21 / TC22/ TC23 (Please refer 'H' Command menu for applicable meanings of mentioned options)

The serial terminal of **GPS TIME SYNC UNIT MC-1-DE** allows the time format in three different ways: NMEA format, NGTS format and T-format. These formats are explained in upcoming chapters. These commands are:

- TC21:** NMEA mode
- TC22:** T-format mode
- TC23:** NGTS mode

Remember that T-format and NMEA sends the time frame each second while the NGTS sends the time frame each minute.

8.2.5 Additional Event's Command:

The additional two event signals are available at the terminal strip on the Front panel of GPS TIME SYNC UNIT MC-1-DE. User can configure these opto-relays through serial port for time ranging from 1 to 86400 seconds individually for separate event outputs. User can configure their Time period as well as their ON time through serial port.

Time Period limit: 1 to 86400 seconds

(0 values are to inhibit/stop particular event output).

ON time limit: 50 milliseconds (min.) to 50% (max.) of particular event time period. Ensure that ON time value of all additional events are to be entered in **milliseconds**.

Whenever the new time period is set, the new event timing counter will start from the very next minute and the contact will be energized after the settable time for that particular event. Please ensure to switch power of the instrument OFF and ON once if the event time period settings are changed.

8.2.5.1 Command: ETx

Applicable Options: ET1 / ET2 (Please refer 'H' Command menu for applicable meanings of mentioned options)

This command is used to configure Time Period of Additional Events. These Events can be configured to trigger at every second to every 86400 seconds (24 hr.). These configuration commands are listed below:

- ET1:** Additional Event1
- ET2:** Additional Event2

8.2.5.2 Command: EWx

Applicable Options: EW1 / EW2 (Please refer 'H' Command menu for applicable meanings of mentioned options)

This command is used to configure ON Time of Additional Events. These Events can be configured to stay ON for a minimum 50 millisecond to 50% of its period. These configuration commands are listed below:

- EW1:** Event1 ON Time
- EW2:** Event2 ON Time

Example:

1. If user has to configure event1 at every 60 seconds interval with pulse ON time width of 50 milliseconds of event time, below values are to configured for event1 output.

ET1 = 60
EW1 = 50

2. If user has to configure event1 at every 60 seconds interval with pulse ON time width of 20% of event time, below values are to configured for event1 output.

ET1 = 60
EW1 = 12000

3. If user has to configure event1 at every 60 seconds interval with pulse ON time width of 50% of event time, below values are to configured for event1 output.

ET1 = 60
EW1 = 30000

NOTE:

- a) Unit of ETx parameter is seconds and EWx parameter is milliseconds (i.e. 1 sec = 1000 milliseconds). Please ensure that the instrument should be power switch OFF/ON after changing the event time settings.

8.2.6 Ethernet Default Command:

Command: ETH0

	<p>It is recommended to remove all NTP outputs RJ-45 cable from network before using this command and stop all the services such as NTP, SNMP, Telnet with GPS TIME SYNC UNIT MC-1-DE because this command will set all NTP output ports IP address to same IP address as a result of which there will be IP conflict in network.</p>
--	---

This command is used to set default network settings of GPS TIME SYNC UNIT MC-1-DE. After Applying this command network settings of all NTP output ports will be as below

IP Address	192.168.100.153
Subnet Mask	255.255.255.0
Gateway	192.168.100.1
SNMP Manager1 IP	192.168.100.226
SNMP Manager2 IP	192.168.100.226
Read Community	masibus
Write Community	masibus
Trap Community	masibus
IRIG-B Time	local
IEEE-1344 C37.118-2005	disable
Telnet User Name	masibus
Telnet Password	masibus

Table 2 Ethernet Default command

User should change the IP address of each NTP port using Telnet connection GPS TIME SYNC UNIT MC-1-DE. Refer document **Appendix E1** for configuring GPS TIME SYNC UNIT MC-1-DE as Telnet Server.

8.2.7 Password Change Command:

The user is allowed to change one password. The command for changing password is:

P(password)

The factory set password is 'MASIBUS'. Suppose, user wishes to change it to 'INDIA', then the command will be:

PINDIA

Remember that the password should not exceed 9 characters. If you try to keep a password that has more than 9 characters, the system will show an error "Invalid Command" and the previous password will be retained.

	<ul style="list-style-type: none"> It is operator's responsibility to remember the configured password if it is changed from factory set password.
---	---

8.2.8 Miscellaneous Command:

Other available commands are as follows:

8.2.8.1 Command: D

Description: This command sets following parameters of GPS TIME SYNC UNIT MC-1-DE to their default Value.

Keypad Parameter	Command	Value	Meaning
SET BAUD RATE	SBx	96	9600 baud rate for Serial terminal
SET PARITY	SPx	0	NONE parity for Serial terminal
SET STOP BIT	SSx	1	1 Stop Bit for Serial terminal
SET TRANSMIT MODE	TC2x	1	NMEA frame on Serial terminal
SET TIME FOR MAT	SUX	2	Local Time Format on serial terminal
ADD EVENT	ETx	60	ET1, ET2 event at 60 seconds
EVENT ON TIME	EWx	50	Pulse width ON time of Event 1 and Event 2 will be set at 50 milliseconds.
Propogation Delay	SPD	0	Propogation Delay is set to 00000
Network Settings	ETH0		All network parameters get defaulted as it is defaulted in ETH0 command.
IRIGB IEEE	I_1344	D	IRIGB IEEE is disabled
IRIG B UTC/Local	IRIG	L	Set Local time for IRIGB

Table 3 Default command

If user enters the default command in GPS TIME SYNC UNIT MC-1-DE, then the serial terminal communication parameters as well as network parameters gets default as per above table. User has to set the PC Serial terminal communication parameters to mentioned default values in order to continue with configuration mode on serial terminal.

	<ul style="list-style-type: none">• This default command does not affect the Manual time.
---	---

8.2.8.2 Command: R

This command will reset GPS TIME SYNC UNIT MC-1-DE.

	<p>This command will reset GPS TIME SYNC UNIT MC-1-DE unit. As a result of which, all the outputs will be stopped or there will be change in relay and pulse output till unit boots up again.</p>
---	---

8.2.9 Antenna Cable Propagation Delay command:

Command: SPDxxxxx (1PPS cable correction command/Propagation Delay)

-Only available on special request

Description: The GPS Timing receiver outputs a 1PPS signal, the rising edge of which is placed at the top of the GPS or UTC one second time mark epoch as specified by the Time Mode command. The 1PPS Cable Delay Correction command allows the user to offset the 1PPS time mark in one nanosecond increments relative to the measurement epoch.

This parameter instructs the GPS receiver to output the 1PPS output pulse earlier in time to compensate for antenna cable delay. Up to one millisecond of equivalent cable delay can be removed. Zero cable delay is set for a zero-length antenna cable.

The user should consult a cable data book for the delay per unit length for the particular antenna cable used in order to compute the total cable delay needed for a particular installation.

This parameter may also be employed by the user to adjust the position of the 1PPS to compensate for other system delays.

Range: 0 to 99999 ns
Default value: 0 ns
Resolution: 1 ns

The user is allowed to change propagation delay. The command for changing propagation delay is: “**SPDxxxx**”

The default propagation delay is 0 ns. Suppose, user wishes to change it to 500 ns, then the command will be:

SPD500 and then press enter.

Remember that the propagation delay should not exceed 99999 ns. If user enters value which is out of applicable range, device will show error message “Invalid Command” and the previous value will be retained.

	<ul style="list-style-type: none"> • Please refer the Table 1 of section 6.1.5 for proper value. • This change in the value of this parameter will bring shift in 1PPS and other output signal timing.
---	--

8.2.10 Manual Time setting command:

Only available on special request

Description: User can set time and date manually using this command. This command is basically used when GPS receivers battery got discharged and antenna is not available then user can enter current time manually.

Manual Time setting Command format is: “**M(hh:mm:ss,dd/mm/yy)**”, where

hh: Hours(0 to 23)

mm: Minutes(0 to 59)

ss: Seconds(0 to 59)

dd: Date(1 to 31)

mm: Month (1 to 12)

yy: Year(for 2012 enter 12).

When antenna is connected to GPS and GPS is locked this command will not work. “**Restart GPS after this command**”.

	<p>Time entered in Manual command will be considered as UTC time, so to set current local time user should enter the time considering the time zone offset require for local time. Once GPS gets locked, the set Manual time will neglected and correct time will be considered.</p>
---	--

8.2.11 Example to illustrate unit commands:

Suppose format available on Serial terminal is by default T-format.

The configuration steps to to change serial terminal format to NGTS, to set the time zone of India, and to set the password to **INDIA** are explained below. The Local time of India is set 5 Hours and 30 Minutes ahead of the UTC.

NOTE: In below example, **Big BOLD** Letters are the command which user has to provide and other texts are the messages returned by GPS TIME SYNC UNIT MC-1-DE device to serial com port HyperTerminal.

H command can be used to view other parameters applicable values.

...
CONFIG
ENTER PASSWORD: *****

PASSWORD OK
ENTER COMMAND TO CONFIGURE PARAMETER.
H FOR HELP MENU.
L FOR PRESENT SETTINGS.
L

PRESENT SETTINGS

COMMAND	MODE NAME	VALUE(x)	MEANING
SBx	Baud Rate	96	9600 Baud Rate
SPx	Parity	0	Parity None
SSx	Stop Bit	1	1 Stop Bits
SUx	Time Format	2	LOCAL time
TC2x	Transmit Mode	1	NMEA Mode
I_1344	IRIGB_ IEEE_1344	D	DISABLED
IRIG	IRIGB_Time	L	LOCAL
Z	TIME_ZONE	+00:00	
ET1	Addi. Event1	00000060	Seconds Mode
ET2	Addi. Event2	00000060	Seconds Mode
EW1	Event1 ON Time	00000050	m.Seconds Mode
EW2	Event2 ON Time	00000050	m.Seconds Mode
SPD	Propagation Delay	00000000	n.second Mode

ENTER COMMAND TO CONFIGURE PARAMETER
OR PRESS ENTER TO CONTINUE.

Z

ENTER THE TIME-ZONE OFFSET ADDED WITH THE DAY-LIGHT SAVING TIME, IF APPLICABLE.

FORMAT: (+/-)(HH):(MM)

ENTER NOW:

+05:30

COMMAND COMPLETE
ENTER COMMAND TO CONFIGURE PARAMETER.
TO CONTINUE PRESS ENTER

TC23

COMMAND COMPLETE
ENTER COMMAND TO CONFIGURE PARAMETER.
TO CONTINUE PRESS ENTER

PINDIA

L

PRESENT SETTINGS

COMMAND	MODE NAME	VALUE(x)	MEANING
SBx	Baud Rate	96	9600 Baud Rate
SPx	Parity	0	Parity None
SSx	Stop Bit	1	1 Stop Bits
SUx	Time Format	2	LOCAL time
TC2x	Transmit Mode	3	NGTS Mode
I_1344	IRIGB_IEEE_1344	D	DISABLED
IRIG	IRIGB_Time	L	LOCAL
Z	TIME_ZONE	+05:30	
ET1	Addi. Event1	00000060	Seconds Mode
ET2	Addi. Event2	00000060	Seconds Mode
EW1	Event1 ON Time	00000050	m.Seconds Mode
EW2	Event2 ON Time	00000050	m.Seconds Mode
SPD	Propagation Delay	00000000	n.second Mode

ENTER COMMAND TO CONFIGURE PARAMETER
OR PRESS ENTER TO CONTINUE.

9. Timing Outputs – Serial, IRIG-B, NTP

9.1 Timing Output – Serial

9.1.1 NMEA-0183 RMC Time frame output

GPS TIME SYNC UNIT MC-1-DE transmits NMEA time frame from serial terminal at front panel of unit at every 1 second at every 1 second at 9600 (baud rate), 8 (Data bits), N (NONE parity), 1 (1 stop bit). User can change the serial communication settings serial configuration method on serial terminal as explained in section 8.2.2. The NMEA-0183 \$GPRMC serial time string contains time and date of position fix, speed and course information.

NOTE: GPS TIME SYNC UNIT MC-1-DE can be configured to transmit T-format or NGTS or NMEA time frame through its serial terminal at front panel. The type of serial frame i.e. NMEA time frame can be selected by parameter “**SET TRANSMIT MODE**” through serial configuration command “**TC21**” as per section 8.2.4.

The full data message of this format shall consist of data fields as follows:

Field	Example	Comments
String ID	\$GPRMC,	
UTC Time	130525.00,	hh:mm:ss.ss,
Status	A,	A = Valid/V = Invalid,
Latitude	4250.5589,	ddmm.mmmm,
N/S Indicator	S,	N = North/S = South,
Longitude	14518.5084,	dddmm.mmmm,
E/W Indicator	E,	E = East/W = West,
Speed over ground	000.1,	Knots,
Course over ground	245.0,	Degrees,
UTC Date	291206,	DDMMYY,
Magnetic variation	,	Degrees,
Magnetic variation	,	E = East/W = West,
Checksum	*25	*CC
Terminator	<CR>,<LF>	Non-displayable characters

Table 4 NMEA Frame structure

9.1.2 T-Format Time frame output:

GPS TIME SYNC UNIT MC-1-DE transmits T-format time frame from serial terminal at front panel of unit at every 1 second at 9600 (baud rate), 8 (Data bits), N (NONE parity), 1 (1 stop bit). User can change the serial communication settings serial configuration method on serial terminal as explained in section 8.2.2.

NOTE: GPS TIME SYNC UNIT MC-1-DE can be configured to transmit T-format or NGTS or NMEA time frame through its serial terminal at front panel. The type of serial frame i.e. T-format can be selected by parameter “**SET TRANSMIT MODE**” through serial configuration command “**TC22**” as per section 8.2.4.

The T-format time string shall consist of 24 printable characters with a concluding CR, LF as follows:

Description	Number of Characters	Character Position	Range of Value/Information
Code Identification	1	1	Capital T
Divider	1	2	:
Year in Century	2	3,4	0 to 99
Divider	1	5	:
Month	2	6,7	1 to 12
Divider	1	8	:
Day of Month	2	9,10	1 to 31
Divider	1	11	:
Day of Week	1	12	1 to 7
Divider	1	13	:
Hours	2	14,15	0 to 23
Divider	1	16	:
Minutes	2	17,18	0 to 59
Divider	1	19	:
Seconds	2	20,21	0 to 59
Divider	1	22	:
GMT Marker	1	23	0 or 1
Validity Marker	1	24	0 or 1
CR [Carriage return]	1	25	Non displayable character
LF [Line Feed]	1	26	Non displayable character

Table 5 T- Format Frame Structure

9.1.3 NGTS Time frame output:

GPS TIME SYNC UNIT MC-1-DE transmits NGTS time frame from serial terminal at front panel of unit at every 1 minute (i.e. NGTS frame is transmitted at every 59 seconds of every minute) at 9600 (baud rate), 8 (Data bits), N (NONE parity), 1 (1 stop bit). User can change the serial communication settings using serial configuration method on serial terminal as explained in section 8.2.2.

NOTE: GPS TIME SYNC UNIT MC-1-DE can be configured to transmit T-format or NGTS or NMEA time frame through its serial terminal at front panel. The type of serial frame i.e. NGTS can be selected by parameter **“SET TRANSMIT MODE”** through serial configuration command **“TC23”** as per section 8.2.4.

The NGTS time string shall consist of 14 printable characters and a concluding CR, LF as follows:

Description	Number of Characters	Character Position	Range of Value/Information
Code Identification	1	1	Capital T
Year in Century	2	2,3	0 to 99
Month	2	4,5	1 to 12
Day of Month	2	6,7	1 to 31
Day of Week	1	8	1 to 7
Hours	2	9,10	0 to 23
Minutes	2	11,12	0 to 59
GMT Marker	1	13	0 or 1
Validity Marker	1	14	0 or 1
CR [Carriage return]	1	15	Non displayable character
LF [Line Feed]	1	16	Non displayable character

Table 6 NGTS frame Structure

9.2 Timing Output – IRIG-B

9.2.1 Introduction

This section should help you with understanding, choosing and connecting the correct output from the GPS TIME SYNC UNIT MC-1-DE to synchronize equipments, such as relays, meters etc. Often, questions arise about how output port should be connected, and how to connect cabling between model MC-1-DE and the relay. Certain protective relays or digital fault recorders may use a different style connector than available at model MC-1-DE outputs. This section will help to answer some common questions, like which type of cabling should be used? Coaxial or a twisted pair etc.

The steps involved in getting your devices synchronized to the model MC-1-DE are fairly simple and should not take long to complete. To expedite the process, make sure that you know:

1. The type of timing signal each piece of equipment requires, and
2. How to enable the equipment to receive the timing signal.

Various methods are used to configure equipment for IRIG-B including setting a physical jumper, or setup program. Some equipment can auto detect the timing signal, so that nothing else is required other than connecting the cable.

9.2.2 Time Code Output:

This section will describe IRIG-B Time Code also availability of the same in model MC-1-DE also configuration for the same. GPS TIME SYNC UNIT MC-1-DE can generate different no of digital as well as analog signals as described in this section.

9.2.2.1 Standard IRIG-B Output:

As per figure 2, GPS TIME SYNC UNIT MC-1-DE model has three, BNC, connectors that supply timing signals to external equipment. Two of output is designed for IRIG-B AM/DCLS and other for 1PPS.

NOTE: On the Front plate of model MC-1-DE IRIG-B DCLS time code signal is referred as IRIG-B TTL.

9.2.2.2 Abstract of IRIG-B Time Code:

The transmission of coded timing signals began to take on widespread importance in the early 1950's. Especially the US missile and space programs were the forces behind the development of these time codes. The definition of time code formats was completely arbitrary and left to the individual ideas of each design engineer due to that hundreds of different time codes were formed, some of which were standardized by the "Inter Range Instrumentation Group" (IRIG) in the early 60's.

Today electronic systems such as communication system, data handling systems require time of day/year for data correlation of data with time. IRIG-B is a serial time code that occurs once per second and depending protocol it contains day of year, hour, minute, seconds, year and other important information. Except these, "IRIG Time Code" other format like IEEE1344 code which is an IRIG coded extended by information for time zone, leap second, etc.

IRIG-B fully described in IRIG Standard 200-04, released by RANGE COMMANDERS COUNCIL of the US Army White Sands Missile Range. IRIG-B format standard allows number of configurations that designated as IRIG-Bxyz, where x indicates the modulation technique, y indicates carrier signal frequency and z indicates data contained in the signal. IRIG-B time code consists of 100 bits out of 74 bit used for time, date, and control functions. The 74 time code bits divided into:

30 bits for BCD value of Seconds, Minutes, Hours, and current day of the year

9 bits for year information
 17 bits for binary value of current day seconds
 18 bits for control functions Also unused bits are filled with logical zero.

9.2.2.3 IRIG-B AM & IRIG-B DCLS signals:

Figure illustrates primary difference between AM-Amplitude Modulated Signal and DCLS- (Pulse Width Modulated Signal). IRIG-B AM is distinctive because of the 1 KHz sine wave carrier. It is similar to IRIG-B DCLS, since Pick-Pick values of the carrier signal follow the same form as IRIG-B DCLS, which contains information.

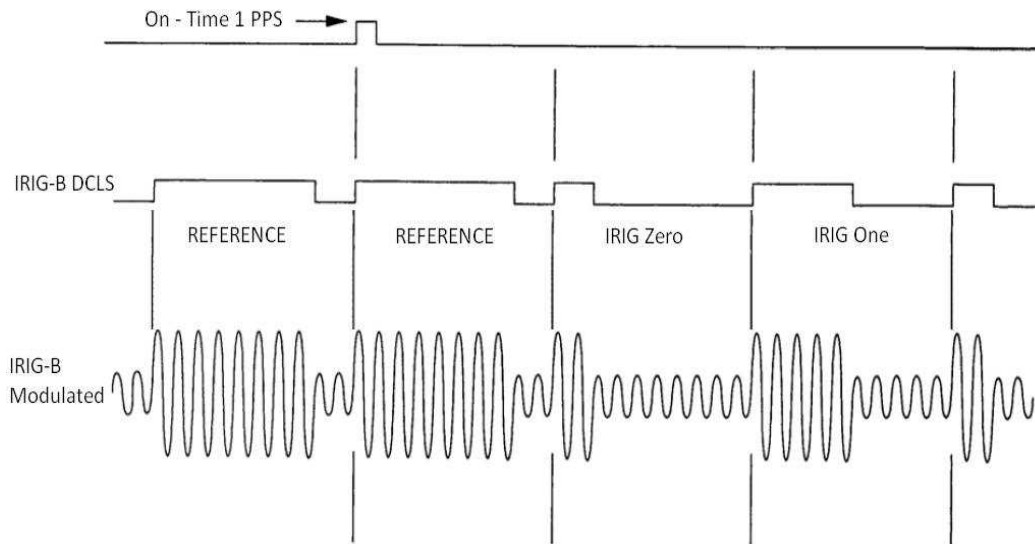

Figure 25 IRIG B Waveform

9.2.2.4 IRIG-B IEEE 1344 Extension:

IEEE 1344 protocol has two versions available of which model MC-1-DE supports is IEEE 1344-2005 which defined in IEEE 1344.C37.118TM-2005 document. IEEE 1344.C37.118TM-2005 extends the Range Commanders Council document by using CF bits of IRIG 200-04. These CF bits are contains information like Time quality, Time offset to get UTC time from frame etc.

Bit no	Designation	Description
50	Year BCD Encoded, BCD 1	Low nibble of BCD encoded Year
51	Year BCD Encoded, BCD 2	
52	Year BCD Encoded, BCD 4	
53	Year BCD Encoded, BCD 8	
54	Separator always Zero	
55	Year BCD Encoded, BCD 10	High nibble of BCD encoded Year
56	Year BCD Encoded, BCD 20	
57	Year BCD Encoded, BCD 40	
58	Year BCD Encoded, BCD 80	
59	P6	Position Identifier #6
60	Leap Second Pending (LSP)*	Becomes 1 up to 59 Sec before leap second inserted

61	Leap Second (LS)*	0 = add leap sec, 1 = Delete leap Sec
62	Daylight Saving Pending (DSP)*	Becomes 1 up to 59 Sec before DST change
63	Daylight Saving Time (DST)*	Becomes 1 during DST
64	Time-zone Offset Sign	Time-zone Offset Sign :- 0=+, 1=-
65	Time-zone Offset BCD encoded, BCD 1	Offset from coded IRIG-B time to UTC time. IRIG coded time plus time offset (Including sign) Equals UTC time.
66	Time-zone Offset BCD encoded, BCD 2	
67	Time-zone Offset BCD encoded, BCD 4	
68	Time-zone Offset BCD encoded, BCD 8	
69	P7	Position Identifier #7
70	Time Zone Offset 0.5 Hour	0 = none, 1=additional 0.5 hour time-zone offset
71	Time Quality	4-bit code representing approx clock time error. 0000 = MC-1-DE Locked, maximum accuracy 1111 = MC-1-DE failed, data unreliable
72	Time Quality	
73	Time Quality	
74	Time Quality	
75	Parity	Parity on All preceding data bits including time of year
76	Not Used	Unassigned, Zero Value
77	Not Used	Unassigned, Zero Value
78	Not Used	Unassigned, Zero Value
79	P8	Position Identifier #8

To use these extra bits of information, protective Relays, RTU's and other equipment receiving the time code must be able to decode them.

	<p>In IEEE 1344 C37.118-2005 Leap Second, Leap Second Pending, Day Light Saving Time, Day Light Saving Time Pending bits are not supported in this firmware version.</p>
---	--

9.2.2.5 Generated IRIG-B Time Codes:

GPS TIME SYNC UNIT MC-1-DE model supports different IRIG-B 00x/IRIG-B12x protocols. Supported protocols are listed below.

- IRIG-B007 : 100 pps, DCLS Signal, No carrier Frequency
BCD TOY, BCDYR, SBS (Time of Day)
- IRIG-B127 : 100 pps, AM Signal, 1 KHz carrier Frequency
BCD TOY, BCDYR, SBS (Time of Day)
- IEEE 1344 (C37.118-2005) : 100 pps, AM Signal, with 1 KHz Carrier frequency
BCD TOY, BCDYR, SBS, IEEE1344 assignment of CF bits (Refer Section 9.2.2.4)
: 100 pps, DCLS Signal, No Carrier Frequency

BCDTOY, BCDYR, SBS, IEEE1344 assignment of CF bits
 (Refer Section 9.2.2.4)

9.2.2.6 Selection/configuration of IRIG-B Time Codes:

The time code generated can be selected/configured using Telnet menu as well as through serial configuration available on model MC-1-DE Ethernet port NTP1 and serial port.

IRIG-B time code for model MC-1-DE can be configured for

- IEEE 1344 C37.118 – 2005 protocol enabling
- UTC time on IRIG-B time code or Local time on IRIG-B time code.

IRIG-B DCLS time codes (IRIG-B 00x) and IRIG-B AM time codes (IRIG-B 12x) are always generated simultaneously. Using telnet if we configure the IRIG-B output for IEEE 1344 protocol than both IRIG-B00x and IRIG-B12x gives IEEE 1344 protocol CF bits output. Similarly, we can configure IRIG-B output for UTC time/ Local time effect of configuration will be on both IRIG-B 00x and IRIG-B 12x.To configure IRIG-B please refer Telnet Appendix E1.

	<ul style="list-style-type: none"> • Configuration of IRIG-B time code using any other Ethernet port except Ethernet port NTP1 and Serial port will not reflect on IRIG-B output port. • All the IRIG-B time code will have same configuration as shown in Telnet menu of Ethernet port NTP1 and in help command of serial configuration.
---	---

9.2.2.7 Connecting IRIG-B Time Code:

GPS TIME SYNC UNIT MC-1-DE time code outputs are designed to handle multiple loads. The output terminals of IRIG-B time code are BNC type. Input devices have different type of IRIG-B time code input connectors. Co-axial cables can be connected directly from model MC-1-DE to end device. To adapt twisted pair cabling with model MC-1-DE, use BNC Breakout or other similar adapter.

NOTE: In case of shielded twisted pair cabling do not connect shielding of cable to model MC-1-DE, ground it at the receiver end.

Following factors come into effect by transmitting time code to multiple/single devices over long distance,

- 1) Resistive loss in cabling
- 2) Electromagnetic interference
- 3) Propagation delay
- 4) Input impedance of end device

1) **Resistive loss in cabling:** -Resistive loss in cabling affects the available output voltage at the input device. Wire has a certain resistivity associated with it that is determined by its metallic composition, and resistance determined by the diameter and length.

2) **Electromagnetic interference:** -Electromagnetic interference (EMI) includes a variety of sources of interfering signals, ranging from dc and low-frequency (50 or 60 Hz) all the way up through the RF (Radio Frequency) and microwave region. All of these signals have the potential to interfere in one way or another with the accurate and reliable distribution of timing signals.

3) **Propagation Delay:** -Electromagnetic waves travel at the speed of light (C) in free space/vacuum and a fraction of that speed through cabling which cause delay in IRIG-B Time code output.

4) **Input impedance of end device:** -By connecting, multiple devices to GPS TIME SYNC UNIT MC-1-DE results in decrease of drive voltage due to increase in load current. In many cases, model MC-1-DE time code output are “fanned out” to a no of devices. The exact no of possible load can be determine from input impedance of each connected devices. To know input impedance of connected devices please refer specific device manual.

9.2.2.7.1 Connecting IRIG-B DCLS (TTL):

To drive multiple load from IRIG-B DCLS output connect all end devices in parallel. To determine load current for one IRIG-B DCLS output

- Determine no of load devices to be connected
- Determine input impedance of each load devices (Rdev)
- Calculate load current of each device ($I_{dev} = 5V \div R_{dev}$)
- Sum all the load device current and compare with model MC-1-DE load capacity current

9.2.2.7.2 Connecting IRIG-B AM:

The main difference in computing the load capacity for IRIG-B AM and IRIG-B DCLS is that some of the modulated IRIG-B decoders are sensitive to the peak-to-peak voltage. Connecting multiple devices with MC-1 IRIG-B AM output causes increase in current flow which affects the Pick-Pick output voltage to decrease. GPS TIME SYNC UNIT MC-1-DE IRIG-B AM Time code signal output impedance is 100Ω.

9.3 Timing Output – NTP

9.3.1 NTP Introduction:

NTP (Network time protocol) is a common method for synchronization of hardware clocks in local and global Ethernet networks. The software package NTP is an implementation of the actual version 3 [Mills90], based on the specification RFC-1305 from 1990 (directory doc/NOTES). NTP protocol is used to synchronize and maintain the time among distributed networks of servers and clients. NTP protocol is evolved from Time protocol but is designed to maintain accuracy and robustness even on the networks involving multiple gateways, high network path delays and unreliable nets. NTP protocol is applied on the application layer on UDP based IP layer.

The purpose of NTP is to convey timekeeping information (in terms of UTC) from NTP servers to other time clients via the Internet and also to cross-check clocks and mitigate errors due to equipment or propagation failures. In NTP basic model, NTP client device sends the NTP packet message over wire to NTP server (time source) at prefixed/defined interval (as per NTP standard). The NTP server interchanges IP addresses and ports, overwrites certain fields in the message, inserts current timestamp in packet, recalculates the checksum and returns the message immediately to NTP client. Information included in the NTP message allows the client to determine the server time with respect to local time and adjust the local clock accordingly. After NTP message is received, NTP client calculates time offset, own local clock frequencies and update in its database at regular intervals to maintain the clock time synchronization with NTP server time. This may result in either a step-change or a gradual phase adjustment in time of the NTP client's local clock to reduce the offset to zero or as minimum as possible. The accuracies achievable by NTP client depend strongly on the precision of the local-clock frequency and stringent control of device and process latencies.

NTP architecture model consists of number of primary reference sources, synchronized by wire or radio clock. There are other several multiple secondary time sources/clients which are arranged in hierarchal manner in network which request time from primary reference sources. Under normal circumstances it is intended that the synchronization subnet of primary and secondary servers assumes

a hierarchical-master-slave configuration with the primary servers at the root and secondary servers of decreasing accuracy at successive levels toward the leaves.

9.4 GPS Time Sync Unit NTP Output:

GPS TIME SYNC UNIT MC-1-DE device is equipped with 10/100 Mbps based Ethernet output port which provides the functionality of NTP server. This NTP output is capable to synchronize time of various NTP clients such as windows PC, Unix/Linux machines and other clients which support NTP protocol. GPS TIME SYNC UNIT MC-1-DE operates at stratum 1 level which is the highest level (in terms of accuracy) after atomic clock providing the NTP timestamp output resolution in milliseconds. Stratum level 1 indicates that a device synchronizes its own clock from radio clock or satellite clock. GPS TIME SYNC UNIT MC-1-DE NTP output operates in Unicast mode in which NTP server responds only when there is NTP request from NTP clients. NTP clients operating at stratum level lower than 1 (i.e. 2 to 15) can synchronize their time from GPS TIME SYNC UNIT MC-1-DE NTP output.

GPS TIME SYNC UNIT MC-1-DE continuous to provide NTP output even under Unlock conditions (when there is no satellite signal available) depending on its internal RTC clock time and accuracy. If required, user can configure stratum level (2 to 15) of NTP output only for holdover conditions which is applicable when GPS TIME SYNC UNIT MC-1-DE device is in Unlock condition. This feature provides the indication to NTP client devices whenever GPS TIME SYNC UNIT MC-1-DE device enters holdover mode during ideal run conditions. Under Lock conditions, GPS TIME SYNC UNIT MC-1-DE NTP output will always operate at stratum level 1 which cannot be changed.

User should change the stratum level GPS TIME SYNC UNIT MC-1-DE device carefully, after having knowledge of its NTP Server-Client network hierarchical level architecture. Stratum level decreases by 1 at every NTP server-client level stages with respect to GPS Time Sync Unit device stratum level.(Stratum at the topmost level (primary GPS servers) is assigned as one and each level downwards (secondary servers) in the hierarchy assigned as one greater than the preceding level). If the stratum level of GPS TIME SYNC UNIT MC-1-DE device is configured at 15 under Unlock conditions, no NTP client will synchronize its time with NTP server output as level 15 is the last limit of stratum as per NTP standard.

```

Network Time Protocol
  Flags: 0x1c
    00.. .... = Leap Indicator: no warning (0)
    ..01 1... = Version number: NTP Version 3 (3)
    .... .100 = Mode: server (4)
  Peer Clock Stratum: primary reference (1)
  Peer Polling Interval: 14 (16384 sec)
  Peer Clock Precision: 0.000001 sec
  Root Delay: 0.0000 sec
  Root Dispersion: 0.0000 sec
  Reference Clock ID: Global Positioning Service
  Reference Clock Update Time: Feb 7, 2036 06:28:18.2679 UTC
  Originate Time Stamp: Feb 7, 2036 06:28:18.2679 UTC
  Receive Time Stamp: Oct 15, 2009 11:33:29.3930 UTC
  Transmit Time Stamp: Oct 15, 2009 11:33:29.3930 UTC
    
```

Figure 26 NTP Time Output

Below are the list of some of all NTP packet parameters which are functionally significant with respect to NTP server.

mode 3-bit integer representing the mode with value “4”, means that GPS TIME SYNC UNIT MC-1-DE device act as NTP server device and can provide time output for synchronization to NTP client devices but will never be synchronized by clients.

Peer clock stratum 8-bit integer representing the stratum with value “1”, which means that GPS TIME SYNC UNIT MC-1-DE act as primary reference source. Stratum value will be fixed at 1 during GPS TIME SYNC UNIT MC-1-DE Lock conditions. However, it can be configured between 2 to 15 (via telnet) which will only be applicable during GPS TIME SYNC UNIT MC-1-DE Unlock conditions.

Clock precision: This is an eight-bit signed integer indicating the precision of the local clock, in seconds to the nearest power of two. GPS TIME SYNC UNIT MC-1-DE is having its internal clock precision of 1 us (1 microseconds = 0.000001s).

Reference Clock identifier This is a 32-bit code identifying the particular reference clock. GPS TIME SYNC UNIT MC-1-DE is stratum 1 primary reference source, it's reference identifier is designated as “GPS”.

Transmit Timestamp Time of the server when the NTP response left for the NTP client, in NTP timestamp format. NTP timestamps are represented as a 64-bit unsigned fixed-point number, in seconds relative to 0h on 1 January 1900 in terms of UTC. The integer part is in the first 32 bits and the fraction part in the last 32 bits. GPS TIME SYNC UNIT MC-1-DE provides time format in seconds and fractional timestamp with a millisecond resolution.



If the stratum level of GPS TIME SYNC UNIT MC-1-DE device is configured at 15 under Unlock conditions, no NTP client will synchronize its time with NTP server output as level 15 is the last limit of stratum as per NTP standard

9.5 NTP Client Synchronization:

GPS TIME SYNC UNIT MC-1-DE NTP output port can be used to synchronize of Windows PC or Unix/Linux based PC in networks. Please refer m05m101-3_Appendix C_issue_No_4 for procedure/settings for making PC to operate as NTP client. It is recommended to visit website www.ntp.org for installing and configuring Unix/Linux based PC as NTP client.

GPS TIME SYNC UNIT MC-1-DE is available with NTP Utility software which can be used to synchronize Windows PC as NTP client device. If NTP Utility software is used, there is no need to do reedit settings in Windows PC for NTP client configuration.

NTP Client time accuracy depends on multiple factors such as Client local clock frequency ppm, network load and congestion, type of clock synchronization algorithm in NTP Client devices other than Unix/Linux PC, hierarchical arrangement of NTP servers and NTP clients in network and GPS TIME SYNC UNIT MC-1-DE NTP Clock output accuracy during holdover conditions (when device is Unlock as per ppm of internal clock crystal) etc.

Since NTP client sends NTP request to NTP server at fixed intervals which can be from few seconds to minutes, as during the interval, time of NTP client depends on its own local clock ppm. If there is too much network load and congestion, there is possibility that NTP request as well as NTP responses to and from NTP clients to NTP servers can be delayed by significant milliseconds at irregular

intervals or NTP packets may be discarded by network (as NTP packet is UDP based transmission packet) since it may cross packet TTL (Time To Live) value in network.

9.6 NTP Hierarchical Time Distribution:

NTP architecture model consists of number of primary reference sources, synchronized by wire or radio clock. There are other several multiple secondary time sources/clients which are arranged in hierarchal manner in network which request time from primary reference sources. Under normal circumstances it is intended that the synchronization subnet of primary and secondary servers assumes a hierarchical-master-slave configuration with the primary servers at the root and secondary servers of decreasing accuracy at successive levels toward the leaves.

NTP Server-client architecture are generally arranged in hierarchical arrangement in network. Refer below figure 27 to understand time distribution model in hierarchical arrangement.

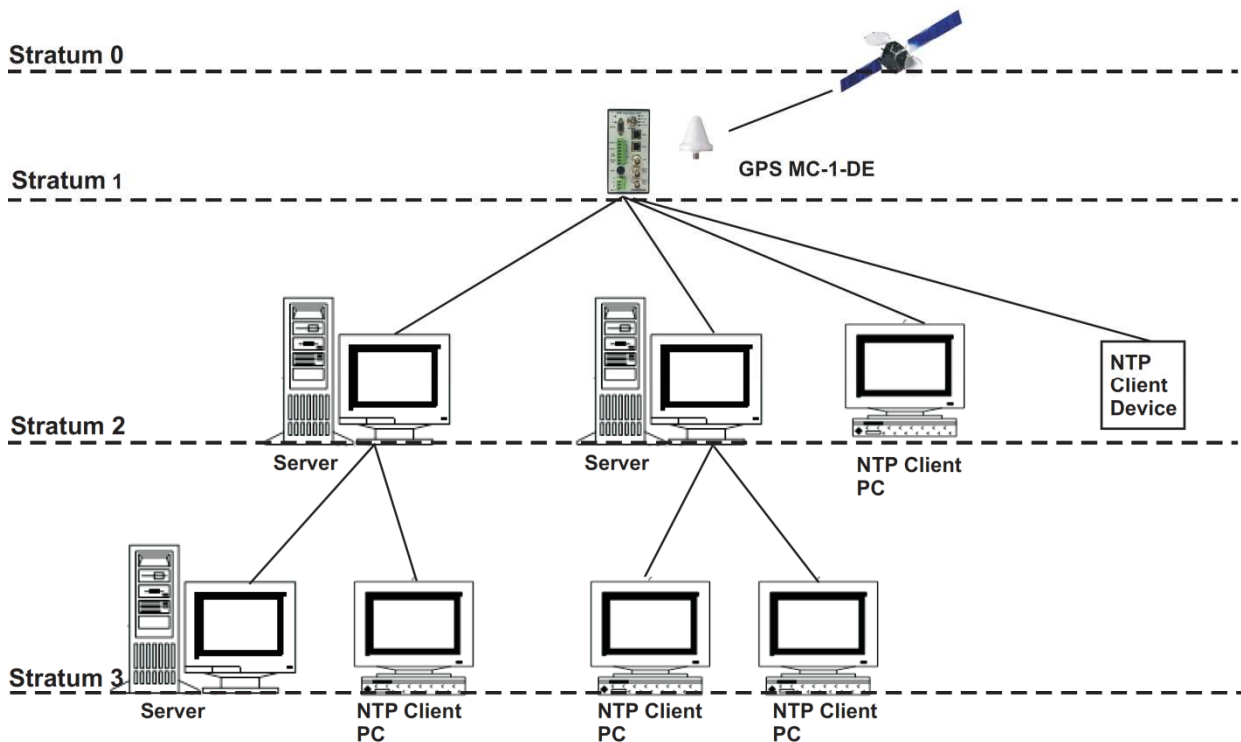

Figure 27 NTP Time distributions in Hierarchical Arrangement

As shown in Figure 27, GPS TIME SYNC UNIT MC-1-DE receives time form GPS Satellites. According to NTP protocol, GPS satellites are considered to be operating at stratum level 0 as most accurate time source. As the devices passes down to other levels of network architecture, stratum level increases by 1. GPS TIME SYNC UNIT MC-1-DE model operates at stratum level 1 which is considered next accurate time source to GPS Satellites. Other NTP clients stratum level increases by 1 as NTP devices goes downwards in network layers. Stratum level can be upto maximum 14 to be considered as valid NTP time source.

NTP client accuracy also depends on the hierarchical arrangement of NTP servers and NTP clients in network because the stratum value increases by 1 at every hierarchical stage in network and as stra-

tum value increases, the accuracy of NTP client decreases depending on the type of NTP server's clock accuracy in hierarchy, processing capabilities of multiple NTP requests and transmission delays.



- If the stratum level of GPS TIME SYNC UNIT MC-1-DE device is configured at 15 under Unlock conditions, no NTP client will synchronize its time with NTP server output as level 15 is the last limit of stratum as per NTP standard.
- Stratum of GPS TIME SYNC UNIT MC-1-DE under Unlock conditions should be such that last NTP client in hierarchical arrangement should be at stratum level 15 so that can be continuously synchronized with its superior level NTP source device.



- I.P. address of two NTP ports in GPS should not be same if both NTP ports are to be used in same network domain.
- It is recommended that NTP output in network should be used only when once GPS TIME SYNC UNIT MC-1-DE is Lock after being power UP. If GPS TIME SYNC UNIT MC-1-DE device was in Power OFF condition for very long duration, RTC battery may get discharged and RTC time will reset to its default time. (Please check the applicable battery backup period mentioned in RTC section).

NOTE:

- Factory set IP of NTP ports are **192.168.100.153 (NTP1) &192.168.100.154(if NTP2 is available as optional output).**
- I.P. address of two NTP ports in GPS should not be same if both NTP ports are to be used in same network domain.
- Among all applicable NTP parameters in NTP packet format, only stratum value can be modified for GPS TIME SYNC UNIT MC-1-DE Unlock condition only. If GPS TIME SYNC UNIT MC-1-DE NTP output stratum value is configured as 15, all NTP clients in network will continue to ignore GPS TIME SYNC UNIT MC-1-DE NTP output as valid time source.
- As NTP protocol is based on UDP transmission protocol (as UDP is a connectionless protocol as there is no acknowledgment for failed packet delivery), NTP requests from NTP clients to NTP servers and NTP responses from NTP servers to NTP clients can be delayed at irregular intervals or rarely discarded if there too much Ethernet packets load/congestion in network.
- There may be rare case that NTP Server responses to some NTP requests from NTP clients may be discarded, if there is large number of simultaneous NTP requests to single NTP server port.
- It is recommended that NTP output in network should be used only when once GPS TIME SYNC UNIT MC-1-DE is Lock after being power up. If GPS TIME SYNC UNIT MC-1-DE device was in Power OFF condition for very long duration, RTC battery may get discharged and RTC time will reset to its default time. (Please check the applicable battery backup period mentioned in RTC section).
- If GPS TIME SYNC UNIT MC-1-DE was Lock for once after being Power UP, GPS TIME SYNC UNIT MC-1-DE will retain accurate NTP output in holdover conditions (according to its local clock ppm accuracy).

- NTP Client time accuracy depends on multiple factors such as Client local clock frequency ppm, network load and congestion, type of clock synchronization algorithm in NTP Client devices other than Unix/Linux PC, hierarchical arrangement of NTP servers and NTP clients in network and GPS TIME SYNC UNIT MC-1-DE NTP clock output accuracy during holdover conditions (when device is Unlock as per ppm of internal clock crystal) etc.
- GPS TIME SYNC UNIT MC-1-DE NTP output is compliant with NTP version 4 NTP request but do not support various authentication schemes as per NTPv4.

10. Relay and Pulse Outputs

10.1 Relay Contact Outputs

GPS TIME SYNC UNIT MC-1-DE device is equipped with 2 Relay contact outputs for indication of WATCHDOG alarm and GPS LOCK status alarm on Front panel of unit. Factory set configuration for relay contacts for all two mentioned outputs is C-NO terminal. Below table represents the relay contact status in various modes.

Note: Relay configuration is factory set configuration, user cannot change the configuration. If user wants to change relay contact configuration please contact masibus customer support.

Relay Contact Configuration: C - NO

MODE	WATCHDOG RELAY STATUS	GPS LOST RELAY STATUS
Unit Power OFF	Contact Open	Contact Open
At Power ON	Contact Close only after some time when the o/p is available on any of the o/p port.	Contact open (if GPS is UNLOCK) or Contact Close (if GPS is LOCK).
Power fail	-	-
Unit Healthy	Contact Close	Contact close if GPS is in Lock condition.
GPS LOCK	-	Contact close

Relay Contact Configuration: C – NC

Unit Power OFF	Contact Close	Contact Close
At Power ON	Contact is close but contact open after some time when the o/p is available on any of the o/p port.	Contact close (if GPS is UNLOCK) or Contact open (if GPS is LOCK)
Power fail	-	-
Unit Healthy	Contact open	Contact open (GPS is in LOCK condition)
GPS LOCK	-	Contact open

Table 7 Relay contact Output

10.2 Pulse Outputs

10.2.1 1PPS output

GPS Time Sync Unit MC -1-DE device provides 1PPS output at every 1 second through its BNC terminal on rear panel of unit. This is TTL signal of 0(low level) to 5V (high level) value. The Pulse width of 1PPS signal is 20% duty cycle i.e. 200 milliseconds (high level) and 800 milliseconds (low level).

10.2.2 Additional Event Outputs (Programmable Pulse Outputs)

GPS TIME SYNC UNIT MC-1-DE device is equipped with the (optional) feature of providing Two additional event outputs. These events provide pulse output according to configured time interval and ON time. Each event time can be configured with time interval ranging from 1 sec to 86400 seconds

and pulse ON time (pulse width) from min. 50 milliseconds to max. 50% of configure time interval of that particular event in terms of milliseconds through front panel serial terminal. Please refer section 8.2.5 for method of configure additional event outputs through serial configuration. Refer technical specification section 4 for electrical characteristics of additional event outputs.

11. Ethernet Communications: Telnet, SNMP

11.1 Telnet

After network connection established the GPS TIME SYNC UNIT MC-1-DE can be configure remotely from a work station using command line interface (Telnet). Telnet configuration GPS TIME SYNC UNIT MC-1-DE is password protected. GPS TIME SYNC UNIT MC-1-DE model several parameters can configure using Telnet are shown in Table. To setup a Telnet connection please refers Appendix E1. MC-1-DE supports only one Telnet session at a time. If the system is not disconnected properly then Telnet session will be timed out and disconnected after 10 minutes.

Command	Description	Reference	
H	Command list supported by model MC-1-DE Model	Appendix E1	
CC	To view Current Configuration of model MC-1-DE model.		
IP	Sets the network IP address, Ethernet port, of model MC-1-DE. After this command connection to Telnet prompt will be lost and user needs to reopen Telnet prompt. Factory set value is : 192.168.100.153		
MASK	Sets the Network IP mask address, Ethernet port, of model MC-1-DE. Factory set Value is : 255.255.255.0		
GTY	Sets the Network IP Gateway (factory set route address), Ethernet port, of model MC-1-DE. Factory set Value is : 192.168.100.001		
SIP1	Sets the IP address of SNMP manager which should receive any Trap messages generated by model MC-1-DE Agent. Factory set value is 192.168.100.226		
SIP2	Sets the IP address of SNMP manager which should receive any Trap messages generated by model MC-1-DE Agent. Factory set value is 192.168.100.226		
SRC	Sets the SNMP Read Community. The input could be any ASCII string with 1-20 characters. Factory set value is: masibus		
SWC	Sets the SNMP Write Community. The input could be any ASCII string with 1-20 characters. Factory set value is masibus.		
STRT	Used to modify stratum of model MC-1-DE when it is not synchronized. Factory set value is 1. For detail about stratum refer Section 9.4.		
U	Sets the User name Telnet session, current Ethernet port, of model MC-1-DE. Factory set Value is masibus (case sensitive).		Appendix E1
P	Sets the Password Telnet session, current Ethernet port, of model MC-1-DE. Factory set Value is masibus (Case Sensitive).		
Z	Sets the time zone of MC-1-DE		
IRIG	Used to configure UTC/Local time on IRIG output port. Factory set Value is No – Transmit local time on IRIG-B Port.		
I_1344	Used to configure IEEE-1344 C37.118-2005 protocol on IRIG-B output port. Factory set Value is No-Disable IEEE 1344.		
SPD	Set the Propagation Delay needs to apply to receiver.		
MT	Sets Manual Time setting.		
Q	Quit the telnet configuration		

Table 8 Configurable Parameters through Telnet

NOTE: 1) NTP output stops during Telnet session in progress.

	<ul style="list-style-type: none"> • NTP output stops during Telnet session in progress. • Refer Manual Appendix E1 for Procedure to Connect and Configure MC-1-DE model through Telnet session.
---	--

11.2 SNMP

The Simple Network Management Protocol (**SNMP**) has been created to achieve a standard for the management and monitoring different devices connected on the same network from some remote location. SNMP has SNMPv1 and SNMPv2c standards available. SNMP is operating on the application layer and uses different transport protocols (like TCP/IP and UDP), so it is network hardware independent. SNMP protocol is having client-server architecture, where server is called as agent and client called as manager.

GPS TIME SYNC UNIT MC-1-DE device supports and operates as SNMPv1 / SNMPv2c agent, designed especially to handle SNMP requests for model MC-1-DE specific status information. GPS Time Sync Unit MC-1-DE SNMP agent is also capable of handling SET requests in order to manage the configuration via SNMP, if SNMP management software is also supports this feature. User need to configure SNMP manager IP address for particular GPS Ethernet IP address using telnet session with that particular Ethernet port.

The elements (objects / variables) are organized in data structures called Management Information Base (MIB).The agent is also responsible for controlling the database of control variables defined in the product's MIB.

11.2.1 SNMP Addressing:

SNMP addressing is structured as a very large tree database. A root node address is an integer value that ranges from 0 to some very large number. Conceptually, there are no limits to the numbers of sub nodes either. SNMP addressing is written in “dotted decimal” notation. For example, the address of GPS TIME SYNC UNIT MC-1-DE product name Enterprise MIB variable is “1.3.6.1.4.1.38306.1.1.0”, this is also known as OID (Object Identifier). The address fragment 1.3.6.1.4.1 is fixed by the IANA (Internet Assigned Number Authority) and is the address of the SNMP Private Enterprise MIB's. The 38306 is the address assigned by IANA to **masibus** for our Enterprise MIB's. **masibus** assigns the addresses after that at our discretion and design.

11.2.2 Protocol Detail:

SNMP operates in the Application Layer of the Internet Protocol Suite. The manager may send requests from any available source port to port 161 to the agent. The agent will response back to the manager address on port 162. The manager receives notifications (Traps and Inform-Requests) on port 162. SNMPv1 specifies five core protocol data units (PDUs). Two other PDUs, Get-Bulk-Request, and Inform-Request were added in SNMPv2. The seven SNMP protocol data units (PDUs) are as follows:

- i) **GET-Request:** This PDU is used to get the values of a list of variables from a Particular host.
- ii) **Get-Next-Request:** This PDU is used to get the next value for multi-valued data-items (for example the entries in a routing table). The manager specifies one or more variables for value, and the agent returns the current value for each of the requested variables.
- iii) **Set-Request:** This PDU is used to set the values of a list of variables for a particular host.

- iv) **Get-Bulk-Request:** This PDU is optimized version of Get-Next-Request, used to request multiple iteration of Get-Next-Request. It allows the caller to specify – non-repeaters, range of variables which are single valued, max-repetition, no of values to be returned by the call.
- v) **Response:** Agent returns this PDU in response to above all PDUs. It contains the requested data items along with a result code.
- vi) **Trap:** This PDU is quite different from other PDUs. Agent generates it in response to particular important events. An agent only at the request of an SNMP manager application generates a trap PDU.
- vii) **Inform-Request:** This PDU introduces a new pattern of communication (Manager to Manager communication). In manager to manager communication, one manager sends information from a MIB view to another manager.

11.2.3 SNMP Operation:

GPS TIME SYNC UNIT MC-1-DE model can work as SNMPv1 and SNMPv2c agent. SNMP Read and Write community used to monitor as well as configure SNMP parameters of model MC-1-DE from some remote location. Read and Write community of model MC-1-DE agent is same for both SNMPv1 and SNMPv2c. model MC-1-DE model supports max 2 SNMP managers.

- **Read Community:** SNMP manager must know Read Community of GPS TIME SYNC UNIT MC-1-DE agent to monitor model MC-1-DE from remote location. GPS TIME SYNC UNIT MC-1-DE model supports 20 character length of Read community. It can be modify using Telnet or SNMP Configuration. For Telnet configuration refer 11.1. Once Read community modified manager needs to remember for further use.

Factory set Value: masibus

- **Write Community:** SNMP Manager must know the Write community of GPS TIME SYNC UNIT MC-1-DE agent to configure SNMP parameters. Model MC-1-DE model supports 20 character length of Write Community. It can be modify using Telnet or SNMP Configuration. For Telnet configuration refer 11.1. Once write community modified manager needs to remember for further use.

Factory set Value: masibus

- **Trap Receiver IP Address:** Trap Receiver IP Address also known as SNMP manager IP address. SNMP manager IP address must be configure to receive asynchronous event like model MC-1-DE synchronized / Not Synchronized via Traps. SNMP manager IP address can be configure using Telnet or SNMP Configuration. For Telnet configuration refer 11.1. Factory set value of both SNMP managers are same.

Factory set Value: 192.168.100.226

- **Trap Enable:** Trap enable field in OID is 1.3.6.1.4.1.38306.2.1.1.2 must set to 1 to enable trap generation for manager IP. By default Trap Enable variable is enabled to generate traps.

Factory set Value: 1 (Enable to generate Traps)



- SNMP manager's IP address must be configured to receive asynchronous traps.
- Please note that particular trap will only be sent if that parameter is configured for trap by Trap enabled option through SNMP.

GPS Time Sync Unit model MC-1-DE can be configured via several user interfaces. Besides the possibility to setup parameters of SNMP using direct shell access via Telnet, SNMP based configuration is also available. In order use the SNMP configuration, you need to fulfill the following requirements:

- i. GPS Time Sync Unit MC-1-DE model MIB file must be present as well as included on the client software.
 - ii. Write community of the client software and GPS model MC-1-DE model must be the same.
- The mentioned MIB file can be found from the CD enclosed with the model MC-1-DE model or you can contact masibus support team at support@masibus.com. For reference here, we have used Ireasoning MIB browser. Below are the steps to configure model MC-1-DE using SNMP.

Note: This SNMP software is free edition software and it is used for testing purpose.

i) Load MIB file to Browser:

Install MIB browser from Ireasoning
 Open Browser from: Start → All Programs → iReasoning → MIB Browser.
 Unload All MIB files from: File → Unload MIB
 Now load masibusGPS.mib from: File → Load MIB → Path where file is saved.
 You can find that MIB file is loaded in SNMP MIBs column.

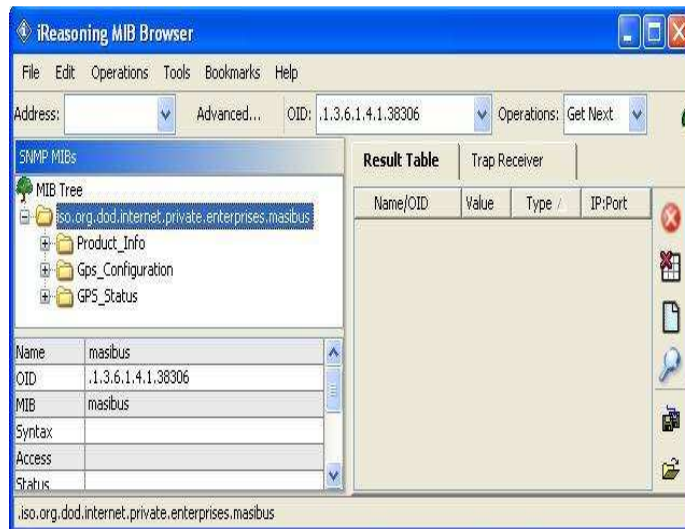

ii) Enter IP address of model MC-1-DE in address Tab:

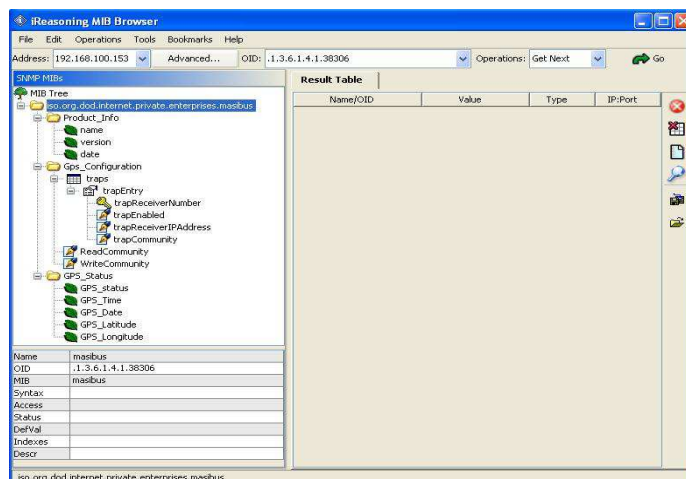

NOTE: Enter IP address in xxx:xxx:xxx:xxx format.

iii) Enter Community/ SNMP version/ Port:



Port: 161
Read Community: masibus (Factory set Value)
Write Community: masibus (Factory set Value)
SNMP Version: 1 or 2 (Select from Dropdown menu)

NOTE: Above value of Read & Write, community is factory set, once they configured SNMP manager Need to remember to operate or monitor from remote location.

iv) **MIB Tree view:**

The MIB of the masibus model MC-1-DE includes following parts:

SNMP Object & OID	Name & OID	Value	Description
Enterprises.38306	masibus 1.3.6.1.4.1.38306	-	Root Node of The masibus MIB
masibus.1	Product_Info 1.3.6.1.4.1.38306.1	String	masibus model MC-1-DE Product information
masibus.2	GPS_Configuration 1.3.6.1.4.1.38306.2	String	masibus model MC-1-DE SNMP configuration variable
masibus.3	GPS_Status 1.3.6.1.4.1.38306.3	String	masibus model MC-1-DE Status variables

SNMP Object Product_Info variables

SNMP Branch & OID	Variable & OID	Data Type	Description
Product_Info	Name 1.3.6.1.4.1.38306.1.1.0	String (R)	A read Only variable display Name of Product
Product_Info	Version 1.3.6.1.4.1.38306.1.2.0	String (R)	A read Only variable display Firmware Version
Product_Info	Date 1.3.6.1.4.1.38306.1.3.0	String (R)	A read Only variable display Firmware Release Date

SNMP Object GPS_Configuration variables:

SNMP Branch	Variable & OID	Data Type & Value	Description
-------------	----------------	-------------------	-------------

GPS_Configuration	Traps 1.3.6.1.4.1.38306.2.1	N.A	Not Accessible
Traps	TrapEntry 1.3.6.1.4.1.38306.2.1.1	N.A	Not Accessible
TrapEntry	TrapReceiverNumber 1.3.6.1.4.1.38306.2.1.1.1	Integer(R) (0-1)	A read Only variable indicating no of SNMP manager supported by model MC-1-DE Agent
TrapEntry	TrapEnabled 1.3.6.1.4.1.38306.2.1.1.2	Integer(R/W) (0-1)	Enable/Disable reception of traps to the SNMP manager. 0 – Disable Traps 1 – Enable Traps
TrapEntry	TrapReceiverIPAddress 1.3.6.1.4.1.38306.2.1.1.3	String(R/W)	SNMP Manager IP address (IPv4)
TrapEntry	TrapCommunity 1.3.6.1.4.1.38306.2.1.1.4	String(R/W) (1 – 20 Characters)	Trap Community
GPS_Configuration	ReadCommunity 1.3.6.1.4.1.38306.2.2.0	String(R/W) (1 – 20 Characters)	SNMP Community which has Read-Only Access can be only used to monitor status variables and configuration values.
GPS_Configuration	WriteCommunity 1.3.6.1.4.1.38306.2.3.0	String(R/W) (1 – 20 Characters)	SNMP Community which has read-write access, can be used to monitor status variables and Get/Set SNMP configuration parameters

SNMP Object GPS_Status variables:

SNMP Branch	Variable & OID	Data Type & Value	Description
GPS_Status	GPS_Status 1.3.6.1.4.1.38306.3.1.0	Integer (R) (0-1)	Variable indicating masibus model MC-1-DE reference clock Synchronized / not Synchronized 0 - Not Synchronized 1 – Synchronized
GPS_Status	GPS_Time 1.3.6.1.4.1.38306.3.2.0	String (R) (1 - 8 Characters)	Variable of string indicating Current masibus model MC-1-DE Time in hh:mm:ss format
GPS_Status	GPS_Date 1.3.6.1.4.1.38306.3.3.0	String (R) (1 – 10 Characters)	Variable of string indicating Current masibus model MC-1-DE Date in dd/mm/yyyy format
GPS_Status	GPS_Latitude 1.3.6.1.4.1.38306.3.4.0	String (R) (1 – 11 Characters)	Variable of string indicating masibus model MC-1-DE position latitude in xxDyy.yyyy N/S format
GPS_Status	GPS_Longitude 1.3.6.1.4.1.38306.3.5.0	String (R) (1 – 12 Characters)	Variable of string indicating masibus model MC-1-DE position longitude in xxxDyy.yyyy E/W format

v) **Get / Get Next / Get Bulk / Set / Walk Command:**

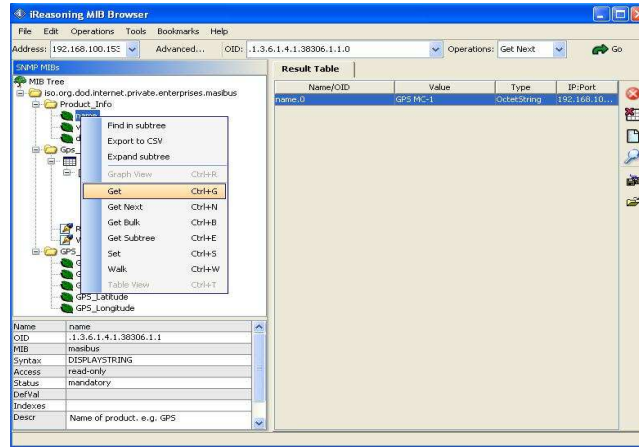

To perform any of Get / Get Next / Get Bulk / Set / Walk command you need to first select variable (corresponding OID).

11.2.4 SNMP Traps

MC-1-DE can send SNMP traps maximum up to two SNMP managers if configured. Available traps in MC-1-DE model are described below.

In trap viewer you can check traps as shown figure. Factory set status of Trap Enable variable is 1 meaning model MC-1-DE agent enabled to generate traps for SNMP Managers.

GPS Status: When MC-1-DE model gets synchronized or unsynchronized SNMP trap receiver will receive the trap, where value 1 indicates model MC-1-DE synchronized and 0 indicates not synchronized.

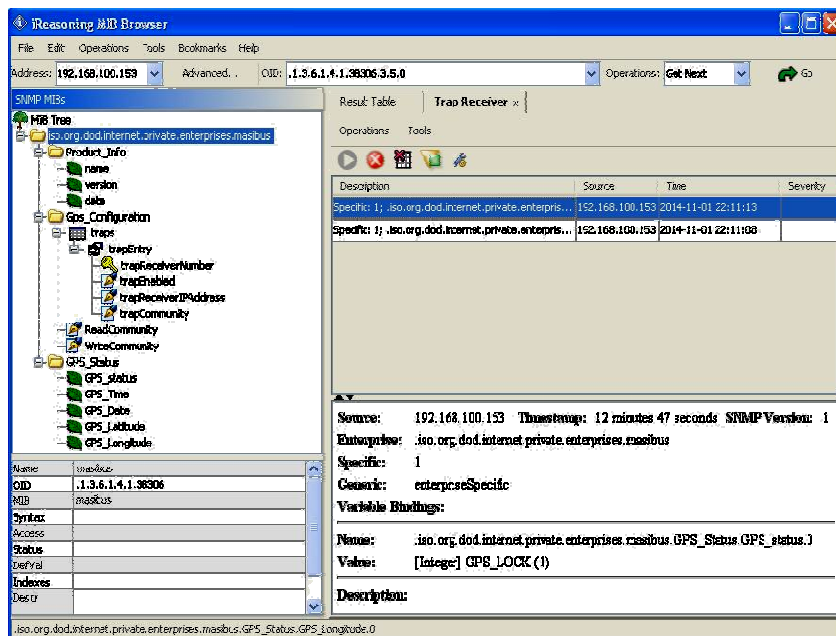

12. Holdover Mode

If GPS TIME SYNC UNIT MC-1-DE is Power ON in Unlock conditions, the unit will provide time output depending on the data of its internal RTC clock time which is available with battery backup (refer section 7.2). However, if the provided battery backup to RTC is discharged due to very long Power OFF period so at Power ON conditions in unlock conditions all outputs of MC-1-DE device will have factory set time value and not the correct time, so when MC-1-DE device gets locked, all outputs will get proper time data. GPS TIME SYNC UNIT MC-1-DE device enter Holdover mode, when unit goes into Unlock condition from Lock condition and thereafter provides time output depending on the internal clock crystal accuracy. The accuracy of all time outputs (including 1PPS output) of unit will degrade depending on the duration during which unit is in Holdover mode and also on the internal clock crystal frequency accuracy. If the Unit again enter the Lock condition from Unlock condition, all the time outputs will become accurate as per UTC time. Holdover mode conditions do not exist if GPS TIME SYNC UNIT MC-1-DE unit gets power reboot while unit was in Unlock condition. GPS TIME SYNC UNIT MC-1-DE outputs will regain its accuracy only when unit gets in lock condition once after Power ON.

13. Options

13.1 Optional Input Power Supply

GPS TIME SYNC UNIT MC-1-DE model is available with optional power input connects to Plug in screw terminal. For AC supply operation connect LINE to (L) terminal, Neutral to (N) terminal and safety ground earth to "E" terminal, where as for DC Supply operation connect the positive lead to the (+) Positive terminal, connect the negative lead to the (-) Negative terminal and safety ground to "E" terminal when viewing instrument from Front.

13.1.1 Option 1: AC/DC Power Input

Input voltages are 85-264 Vac, 47-63 Hz or 120-300Vdc, less than 10 VA typical.

Input Power

AC Voltage Range	:	85 – 264 V _{AC}
Frequency	:	47 – 440 Hz
DC Voltage Range	:	120 – 300 V _{DC}
Power Consumption	:	< 10 W (Typical)

Fuse

Current Rating	:	3.15 Ampere
Voltage Rating	:	250 Volts

13.1.2 Option 2: DC Power Input

Input voltages are 18-72Vdc, less than 10 VA typical.

V _{DC} DC Power Supply Input	:	18 – 75 V _{DC}
Power Consumption	:	< 10 W (Typical)

Fuse

Current Rating	:	3.15 Ampere
Voltage Rating	:	250 Volts

NOTE: This power consumption is for MC-1-DE without optional output.

14. Appendix List

Below is the list of GPS TIME SYNC UNIT MC-1-DE model supported manuals.

Appendix C "m05om101-3_Appendix C_Issue_no04.doc"
– Procedure to configure Windows / Linux PC as NTP Client

Appendix D "m05om101-01_Appendix D_01B_100559.doc"
– Procedure to configure Unix PC as NTP Client

Appendix E "m05dom102_Appendix E1_Issue 00.doc"
– Procedure to configure PC as Telnet Client for GPS Telnet communication

Appendix F "m05om101_04_Appendix-F_Issue 01.doc"
– Masibus NTP Utility Software User Guide

15. Troubleshooting

Unit not getting Power ON

Below mention, points need to be check to troubleshoot this problem.

1. Check Power input cable connected properly
2. Check Power input cable connected to respective terminal as described in section 13.1
3. Check Input power is available.
4. Check fuse is melted or not, if fuse is melted please contact masibus support department.

No output is available at Unit Power ON

If the unit was kept in Power OFF conditions for the duration more than 15 days, as per mentioned in section 7.2, the battery back of internal RTC will get discharged completely. As a result, at unit Power ON, No output is available so either unit must be connected to the Antenna or enter the correct time through telnet or serial configuration using manual time setting. If the battery is discharged as per mentioned above, it is necessary to keep unit in Power ON condition for duration mentioned in section 7.2, for full charging of internal battery. Full charging is necessary to avoid possibility of wrong time output at unit Power ON.

GPS TIME SYNC UNIT MC-1-DE not as per Local time

If GPS TIME SYNC UNIT MC-1-DE time at NGTS & T-format time output, all event Outputs is not as per Local time, the Timezone offset w.r.t UTC may not be set as per required Time offset for the region/country where unit is installed. Please refer section 8.2.3 to set Timezone offset through serial configuration. Apart from timezone offset, it is necessary that the setting of time format (UTC/LOCAL) should be set to LOCAL. For setting this parameter to LOCAL, user can set it through serial communication or through telnet.

Cannot establish Serial communication with Serial terminal

RS-232 cable used for serial communication with serial terminal should be cross cable as per section 8.1. Also, the serial communication parameters such as baud rate, parity, stop bits of serial terminal are configurable through configuration menu. It is necessary to match the end device serial communication parameters as per configured in GPS TIME SYNC UNIT MC-1-DE unit. If user forgot baud rate, parity bit, stop bit then user has to press the switch which is available on the rear panel of the unit. It will default all the network as well as serial related parameter.

Not able to do configuration through serial terminal

In order to configure GPS TIME SYNC UNIT MC-1-DE unit through serial configuration serial terminal, it is necessary to enter correct password (when asked for, refer section 8.2.1.) in serial communication terminal software of remote PC. Factory set password when shipped from factory is **masibus**. If user changes the configuration password through serial configuration, factory set password will be replaced with new configured password.

If user forgot baud rate, parity bit, stop bit then user has to press the switch which is available on the rear panel of the unit. It will default all the network as well as serial related parameter.

NOTE: Password used for unit parameters configuration through serial communication are different. If user has forgotten its own configured password for serial configuration menu, user should contact Masibus Service department.

Problem with getting unit LOCK to GPS satellites

- 1) It is always recommended to use factory provided antenna cable shipped with GPS TIME SYNC UNIT MC-1-DE unit. If antenna cable used for installation is other than provided with GPS TIME SYNC UNIT MC-1-DE unit, please contact Masibus Service department for assistance.
- 2) GPS Antenna must be installed properly as per suggested in section 6.1.1 and 6.1.2.
- 3) GPS Antenna cable must be connected at the antenna connection on front panel of GPS TIME SYNC UNIT MC-1-DE device.
- 4) Refer section 6.1.5 for antenna cable technical details.
- 5) Check Antenna cable continuity. Unplug the antenna cable connection from GPS Antenna and antenna connector on GPS TIME SYNC UNIT MC-1-DE front panel. Short the Antenna cable at any one end and check the continuity at other end using Digital MultiMate. If there is any break in continuity, contact Masibus service department for rectification.
- 6) If antenna cable is proper, refer section 6.1.3 for further diagnostics.
- 7) If GPS TIME SYNC UNIT MC-1-DE device is able to capture very less number of satellites even if the weather and sky is clear, try to re-orient the GPS antenna or relocate the GPS antenna so that maximum number of GPS satellites is visible.

IRIG-B / IEEE 1344 client synchronization fail

Following steps are to be checked for issues of IRIG-B synchronization failure or loss.

- 1) IRIG-B BNC cable should be tightly connected and locked at GPS front panel IRIG terminal and at IRIG-B client device terminal.
- 2) If IRIG client device terminal is other than BNC type connector, ensure that IRIG connection is done with correct polarity at client device terminal end.
- 3) Total number of IRIG-B/IEEE 1344 compatible devices connected on the IRIG TTL or IRIG-AM terminal of GPS TIME SYNC UNIT MC-1-DE be determined considering the maximum electrical load capacity as specified in GPS TIME SYNC UNIT MC-1-DE specification. Refer product specifications and section 9.2.2.4 for further details.

No response to Ping Command

Below steps are to be checked for troubleshooting the mentioned issue:

- 1) GPS TIME SYNC UNIT MC-1-DE is shipped with factory set Ethernet configuration (IP, gateway and subnet address) depending on the provided standard and optional Ethernet ports.
- 2) Check the connection route from GPS TIME SYNC UNIT MC-1-DE Ethernet port to end device and configuration of intermediate Ethernet switches and gateways. GPS TIME SYNC UNIT MC-1-DE Ethernet port addresses of subnet and gateway should be configured as per network domain architecture.
- 3) If the unit is directly connected to remote PC using RJ-45 cable, it is recommended to connect unit through Ethernet switch or using cross RJ-45 cable configuration.

- 4) User should configure the IP address of all Ethernet outputs as per network domain configurations where GPS TIME SYNC UNIT MC-1-DE device is to be installed. User can configure IP address of Ethernet port using telnet connection with respective Ethernet NTP port. It is recommended to Power recycle the unit after all Ethernet NTP ports are configured with new IP address.

Not able to configure IP address of Ethernet Port

- 1) Refer points 2 & 3 of troubleshoot index.
- 2) For configuring new network settings of particular Ethernet port, user should enter old IP address of GPS Ethernet port during telnet communication. Ensure that pinging with old/previous IP address of GPS Ethernet port should be stopped before proceeding for IP configuration. It is also recommended to stop all IP related process such as NTP, SNMP with the old GPS IP address before starting IP configuration.
- 3) At a time, only one telnet communication with particular Ethernet port of GPS TIME SYNC UNIT MC-1-DE device is allowed.
- 4) It is necessary to exit the telnet communication after doing necessary Ethernet settings failing of which, GPS TIME SYNC UNIT MC-1-DE will not allow to reconnect with telnet session on same IP address. Please refer section 11.1 & manual Appendix E1 for telnet session and configuration.

NTP client not synchronizing with GPS NTP output port

Following steps are to be checked for issues of NTP communication failure or NTP client time not synchronizing with GPS NTP Server port.

- 1) IP address of GPS NTP port and NTP client device should be same network domain.
- 2) Please verify the Ethernet connection between GPS NTP port and NTP server device by pinging the IP address of GPS NTP port. If IP address of GPS NTP port is not reachable, NTP communication will be failed. Refer troubleshooting index.
- 3) GPS NTP Server port IP address should be properly configured in NTP client device.
- 4) Various NTP parameters should be configured properly in NTP client device.
- 5) If ntp client device is a computer machine based on Windows or Unix based or Linux based, please refer manual m05om101_01_ Appendix C_Issue No 04 for proper configuration and time synchronization method of client device.
- 6) Please refer section 9.3.3. and manual m05om101_01_ Appendix C _Issue No 04 for understanding NTP client time synchronization method.

Loss of time synchronization by NTP Client during GPS Unlock

If NTP client loses time synchronization when GPS TIME SYNC UNIT MC-1-DE is in Unlock condition and resume when GPS TIME SYNC UNIT MC-1-DE comes in LOCK condition, check the configured NTP stratum value in GPS Time Sync Unit device. It should be less than 15 or applicable value depending on NTP hierarchical architecture arrangement as explained in section 9.3 and 9.3

Loss of time accuracy in all outputs during Unit Power ON in Unlock conditions

When GPS TIME SYNC UNIT MC-1-DE comes in UNLOCK condition from LOCK condition during normal operation, unit enters in holdover mode. Refer section 12 for technical explanation of holdover mode.

Cannot establish telnet communication

- 1) IP address of GPS Ethernet port and telnet device should be same network domain.
- 2) Please verify the Ethernet connection between GPS Ethernet port and telnet device by pinging the IP address of GPS Ethernet port. If IP address of GPS Ethernet port is not reachable, telnet connection will fail.
- 3) Provide correct IP address of GPS Ethernet port while trying to establish telnet connection. Refer manual Appendix E1 for procedure for telnet connection with GPS Ethernet port.

Cannot establish SNMP communication

- 1) IP address of GPS Ethernet port and SNMP manager should be in the same network domain.
- 2) Please verify the Ethernet connection between GPS Ethernet port and SNMP manager by pinging the IP address of GPS Ethernet port. If IP address of GPS Ethernet port is not reachable, SNMP connection will fail. Refer troubleshooting index.
- 3) SNMP Manager should be able to work on SNMPv1 and SNMPv2c protocol.
- 4) MIB file at manager side for model MC-1-DE agent should be the same provided at the time of commissioning.
- 5) Read or Write Community of SNMP manager and model MC-1-DE agent should be same.

Not able to receive SNMP traps

- 1) IP address of GPS Ethernet port and SNMP manager should be in the same network domain.
- 2) Please verify the Ethernet connection between GPS Ethernet port and SNMP manager by pinging the IP address of GPS Ethernet port. If IP address of GPS Ethernet port is not reachable, SNMP connection will fail. Refer troubleshooting index.
- 3) SNMP Manager should be able to work on SNMPv1 and SNMPv2c protocol.
- 4) SNMP manager IP should be configure in model MC-1-DE agent.
- 5) Trap enable variable should be enabled.

Not Able to set SNMP parameter

- 1) IP address of GPS Ethernet port and SNMP manager should be in the same network domain.
- 2) Please verify the Ethernet connection between GPS Ethernet port and SNMP manager by pinging the IP address of GPS Ethernet port. If IP address of GPS Ethernet port is not reachable, SNMP connection will fail. Refer troubleshooting index.
- 3) SNMP Manager should be able to work on SNMPv1 and SNMPv2c protocol.
- 4) MIB file at manager side for model MC-1-DE agent should be the same provided at the time of commissioning.
- 5) Write Community of SNMP manager and model MC-1-DE agent should be same.

16. Abbreviations

1PPS	:	Pulse per Second
AM	:	Amplitude Modulation
AC	:	Analog Current
BNC	:	Bayonet Neill–Concelman Connector
BCD	:	Binary Coded Decimal
BCDYR	:	Binary Coded Decimal Year
BCDTOY	:	Binary Coded Decimal Time of Year
CE	:	Conducted Emission
CISPR	:	International special committee on Radio Interference
CF	:	Control Function
CR	:	carriage return
CRO	:	Cathode Ray Oscillator
CDMA	:	code division multiple access
DB9	:	D-Subminiature connectors, and houses 9 pins
dB	:	Decibels
DC	:	Direct Current
DCLS	:	<i>Direct Current Level Shift</i>
DST	:	Day-Light Saving Time
DSP	:	Day-light Saving Pending
ESD	:	Electrostatic discharge
EMI	:	Electro-Magnetic interference
FDMA	:	Frequency Division Multiple Access
GMT	:	Greenwich Mean Time
GPS	:	Global Positioning System
GNSS	:	Global Navigation Satellite System
IPv4	:	Internet Protocol version 4
IRIG	:	Inter Range Instrumentation Group
IP67	:	Ingress Protection Marking - 67
IED	:	Intelligent Electronic Device
IEC	:	International Electrotechnical Commissions
IST	:	Indian Standard Time
IEEE	:	<i>Institute of Electrical and Electronics Engineers</i>
IANA	:	<i>Internet Assigned Numbers Authority</i>
LCD	:	Liquid-Crystal Display
LED	:	light-emitting diode
LF	:	Line Feed
LSP	:	Leap Second Pending
LS	:	Leap Second
MIB	:	<i>Management Information Base</i>
mAh	:	milli Ampere Hour
mS/msec	:	milliseconds
Mbps	:	Megabits per Second
NTP	:	Network Time Protocol
NMEA	:	National Marine Electronics Association
OCXO	:	Oven Controlled Crystal Oscillator
OID	:	Object Identifier
PC	:	Personal Computer
ppm	:	Parts per million
PPH	:	Pulse Per Hour

PPM	:	Pulse Per Minute
PTP	:	<i>Precision Time Protocol</i>
UTC	:	Coordinated Universal Time
UDP	:	User Datagram Protocol
RCC	:	<i>Range Commanders Council</i>
RTC	:	Real Time Clock
RFC	:	Request For Comments
RE	:	Radiated Emission
RG-6/RG-8	:	Radio Grade - 6
RF	:	Radio Frequency
SA	:	Selective Availability
SBS	:	Straight Binary Second
SNTP	:	Simple Network Time Protocol
SNMP	:	Simple Network Management Protocol
TCP	:	Transmission Control Protocol
TCXO	:	Temperature Compensated Crystal Oscillator
TDR-4	:	Time Distribution Rack – 4
TDU-64	:	Time Display Unit - 64
Telnet	:	Telecommunication Network
TSR-4	:	Time Signal Repeater - 4
TTL	:	Transistor Transistor Logic